



Graphical Mode Examples Guide

Thermo-Calc Version 2026a



Graphical Mode Examples Listed by Product

This guide includes descriptions of the following examples.

<i>Category</i>	<i>Example number</i>
<p>The Thermo-Calc collection includes binary and ternary system examples, Scheil, the Equilibrium Calculator, Material to Material Calculator, plus more.</p> <p>"Thermo-Calc Examples Collection" on page 1</p>	<p>T_01 to T_22</p>
<p>General Property Models Library</p> <p>"Thermo-Calc General Property Models Examples Collection" on page 61</p>	<p>General Models: PM_G_01 to PM_G_20</p>
<p>Add-on Modules and Material Specific Property Model Libraries (in Alphabetical Order)</p>	
<p>"Additive Manufacturing (AM) Module Examples Collection" on page 113</p>	<p>AM_01 to AM_15</p>
<p>"Diffusion Module (DICTRA) Examples Collection" on page 233</p>	<p>D_01, D_02, D_03 (the Quick Start Guide Examples)</p> <p>D_04 to D_10</p>
<p>"Nickel Model Library Examples Collection" on page 378</p>	<p>Nickel Property Models: PM_NI_01 to PM_Ni_04</p>
<p>"Noble Metal Alloys Model Library Examples Collection" on page 388</p>	<p>Noble Metals Property Models: PM_Noble_01</p>
<p>Precipitation Module (TC-PRISMA) Examples Collection</p>	<p>P_01 to P_16</p>
<p>"Process Metallurgy Module Examples Collection" on page 352</p>	<p>PMET_01 to PMET_08</p>
<p>"Steel Model Library Examples Collection" on page 393</p>	<p>Steel Property Models: PM_Fe_01 to PM_Fe_12</p>
<p>"Titanium Model Library Examples Collection" on page 425</p>	<p>Titanium Property Models: PM_Ti_01 to PM_Ti_02</p>

Thermo-Calc Examples Collection



These are the Graphical Mode examples. There are separate Console Mode examples also available.

In this section:

T_01: Calculating a Single-Point Equilibrium	3
T_02: Stepping in Temperature in the Fe-C System	5
T_03: Fe-C Phase Diagrams	7
T_04: Fe-Cr-C Ternary Phase Diagram at 1000 K	9
T_05: Stable and the Metastable Fe-C Phase Diagrams	11
T_06: Serially Coupled Equilibrium Calculators	13
T_07: User-Defined Functions	15
T_08: Scheil and Equilibrium Solidification	17
T_09: Carbide Driving Force Heat Map	20
T_10: Scheil Solidification with Back Diffusion	22
T_11: Surface Tension in Cu-Zr	24
T_12: Viscosity in Cr-Ni	26
T_13: Scheil Solidification with Solute Trapping	28
T_14: Fe-Cr-Ni Transition Comparison Using the Material to Material Calculator	30
T_15: Molar Volume and Thermal Expansion Coefficients for L12-type Al ₃ Sc and Al ₃ Zr Compounds	33
T_16: Electrical Resistivity and Thermal Conductivity for Pure Copper	36
T_17: Al ₂ O ₃ -MgO Phase Diagram	40
T_18: Scheil with Delta Ferrite to Austenite Transition	42
T_19: Young's Modulus for Ti-O with Elastic Properties	44
T_20: Ternary Diagram with Clockwise Plot Axes	47

T_21: Pourbaix Diagrams of Fe with the Aqueous Calculator	50
T_22: Aqueous pH of Solutions	56

T_01: Calculating a Single-Point Equilibrium

This example shows the result from a single-point equilibrium calculation in the Fe-C system. It demonstrates the use of the Equilibrium Calculator and generates a Table Renderer in the **Visualizations** window. The number of equilibrium conditions is $C+2$ where C is the number of components, meaning that four conditions are needed in this example:

- **Temperature** is 1000 K
- **Pressure** is 100000 Pa
- **System size** is 1 mole
- **Mass percent carbon** is 0.1%

Project File Information

- Folder: **Thermo-Calc**
- File name: *T_01_Single-point_equilibrium.tcu*

Table Results



This example is included as a tutorial on our [website](#) and as part of the Graphical Mode Examples playlist on our [YouTube channel](#).

Open the example project file to review the node setup on the **Project** window and the associated settings on the **Configuration** window for each node. For some types of projects, you can also adjust settings on the **Plot Renderer Configuration** window to preview results before performing the simulation. Click **Perform Tree** to generate plots and tables to see the results on the **Visualizations** window.

Visualizations				
Table Renderer 1				
System				
Moles	1.00000			
Mass	55.64392	[g]		
Temperature	1000.00000	[K]		
Total Gibbs Energy	-42141.28527	[J]		
Enthalpy	24706.54116	[J]		
Volume	7.30429E-6	[m ³]		
Component	Mole Fraction	Mass Fraction	Activity	Potential
C	0.00463	0.00100	0.21816	-12658.89428
Fe	0.99537	0.99900	0.00619	-42278.50542
Stable Phases				
BCC_A2#1	Moles	Mass	Volume Fraction	<input type="text" value="Composition"/>
	0.99609	55.59692	0.99711	
Composition				
Component	Mole Fraction	Mass Fraction		
Fe	0.99928	0.99984		
C	0.00072	0.00016		
GRAPHITE#1	Moles	Mass	Volume Fraction	<input type="text" value="Composition"/>
	0.00391	0.04700	0.00289	
Composition				
Component	Mole Fraction	Mass Fraction		
C	1.00000	1.00000		
Fe	0.00000	0.00000		

Figure 1: The displayed results of the calculation show that the BCC_A2 (ferrite) and GRAPHITE phases are stable for this set of equilibrium conditions.

T_02: Stepping in Temperature in the Fe-C System

This example shows how the fractions of stable phases vary for an Fe-0.1 mass-% C alloy when the temperature is varied between 500 and 2000 K. It demonstrates the use of the Equilibrium Calculator. To allow temperature to vary, the corresponding **Axis Definition** checkbox is selected.

Project File Information

- Folder: **Thermo-Calc**
- File name: `T_02_Step_in_temperature_in_Fe-C.tcu`

Visualizations



This example is included as a tutorial on our [website](#) and as part of the Graphical Mode Examples playlist on our [YouTube channel](#).

Open the example project file to review the node setup on the **Project** window and the associated settings on the **Configuration** window for each node. For some types of projects, you can also adjust settings on the **Plot Renderer Configuration** window to preview results before performing the simulation. Click **Perform Tree** to generate plots and tables to see the results on the **Visualizations** window.

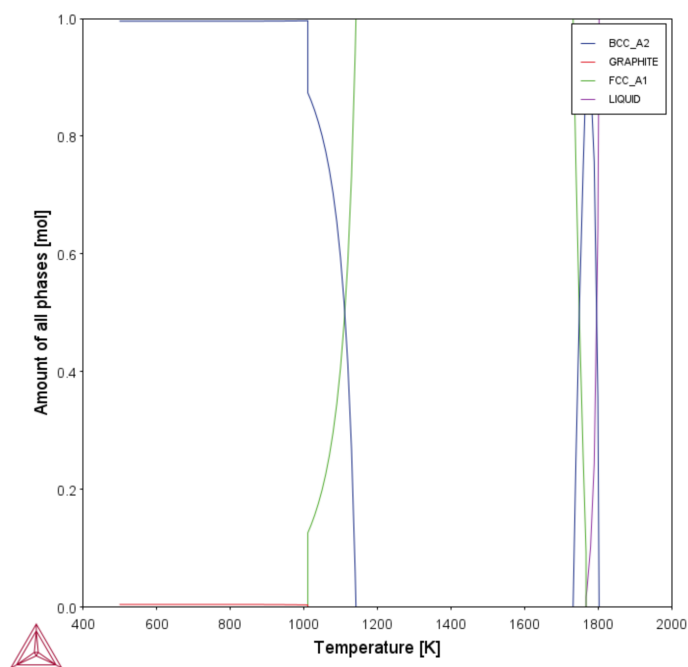



Figure 2: In this example, results are displayed graphically using a Plot Renderer activity.



For the Plot Renderer, there is an option to use the  **Table View** button to convert plots to table data for all calculation types and calculators.

If you want, you can also use a Table Renderer to generate text results instead, as shown in this example after adding a Table Renderer to the Equilibrium Calculator and clicking **Perform**.

Results				
Plot Renderer 1		Table Renderer 1		
Temperature [K]	Volume fraction of BCC_A2	Volume fraction of FCC_A1	Volume fraction of GRAPHITE	Volume fraction of LIQUID
1000.00000	0.99711		0.00289	
1010.00000	0.99718		0.00282	
1011.17630	0.99719		0.00281	
1011.17630	0.99719	0.00000	0.00281	
1011.17630	0.87704	0.12296	0.00000	
1011.17630	0.87704	0.12296		
1020.00000	0.86401	0.13599		
1030.00000	0.84702	0.15298		
1040.00000	0.82743	0.17257		
1050.00000	0.80486	0.19514		

T_03: Fe-C Phase Diagrams

This example shows the stable Fe-C phase diagram (stable meaning that the graphite phase is entered in the calculation). The same diagram is calculated using the Binary Calculator activity and then using a System Definer and Equilibrium Calculator.

In both cases, a Plot Renderer is used to display results. The purpose of the **Binary Calculator** is to simplify common calculations for binary systems. In the **Equilibrium Calculator** two Axes are defined on the **Plot Renderer**. An axis variable must be an equilibrium condition.

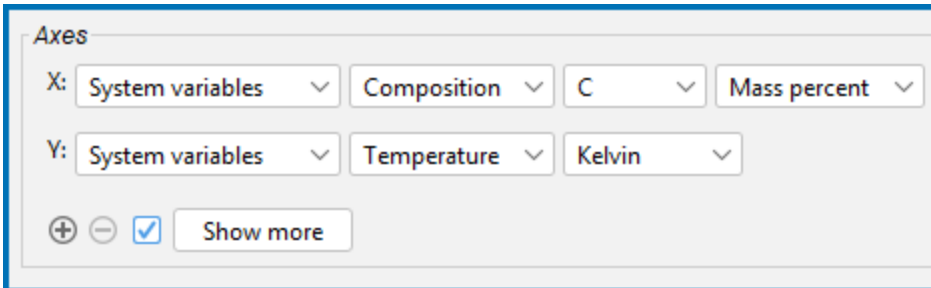

Axes

X: System variables Composition C Mass percent

Y: System variables Temperature Kelvin

+ - Show more



In the **Plot Renderer** settings window, click **Show more** and **Show less** to toggle between viewing all or some of the available settings.

Project File Information

- Folder: **Thermo-Calc**
- File name: *T_03_Fe-C_phase_diagram.tcu*

Visualizations



This example is included as a tutorial on our [website](#) and as part of the Graphical Mode Examples playlist on our [YouTube channel](#).

Open the example project file to review the node setup on the **Project** window and the associated settings on the **Configuration** window for each node. For some types of projects, you can also adjust settings on the **Plot Renderer Configuration** window to preview results before performing the simulation. Click **Perform Tree** to generate plots and tables to see the results on the **Visualizations** window.

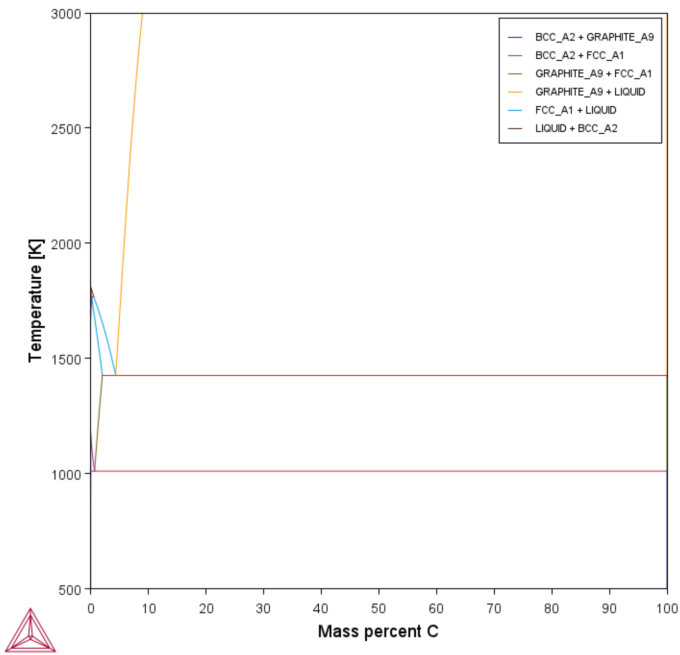

Figure 3: The plot result of the System Definer and Equilibrium Calculator.

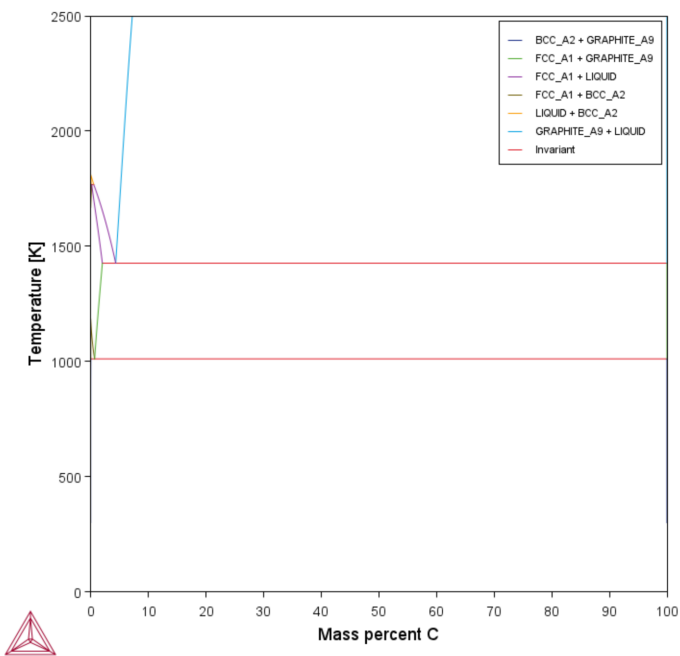

Figure 4: The plot result of the Binary Calculator simulation.

T_04: Fe-Cr-C Ternary Phase Diagram at 1000 K

This example shows a ternary phase diagram in the Fe-Cr-C system at 1000 K. Similar to example "T_03: Fe-C Phase Diagrams" on page 7, the same diagram is calculated using a Ternary Calculator and then using a System Definer and Equilibrium Calculator. Two Plot Renderer activities are added to create two plots.

Project File Information

- Folder: **Thermo-Calc**
- File name: *T_04_Fe-Cr-C_ternary_phase_diagram.tcu*

Visualizations





This example is included as a tutorial on our [website](#) and as part of the Graphical Mode Examples playlist on our [YouTube channel](#).

Open the example project file to review the node setup on the **Project** window and the associated settings on the **Configuration** window for each node. For some types of projects, you can also adjust settings on the **Plot Renderer Configuration** window to preview results before performing the simulation. Click **Perform Tree** to generate plots and tables to see the results on the **Visualizations** window.



In the **Plot Renderer** settings window, click **Show more** and **Show less** to toggle between viewing all or some of the available settings.

Try practicing with two features on the **Plot Renderer Configuration** window.

- To toggle between a triangular and a rectangular diagram, click the  **Toggle Triangular/Regular Diagram** button then click **Perform** to see what happens.
- To toggle the X and Y axis variables, click the  **Switch Axes** button and then click **Perform**.

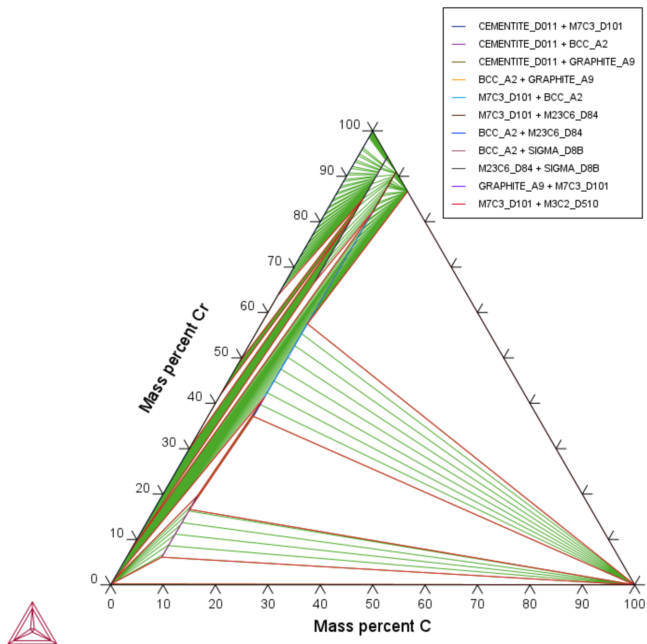

Figure 5: Ternary Calculator.

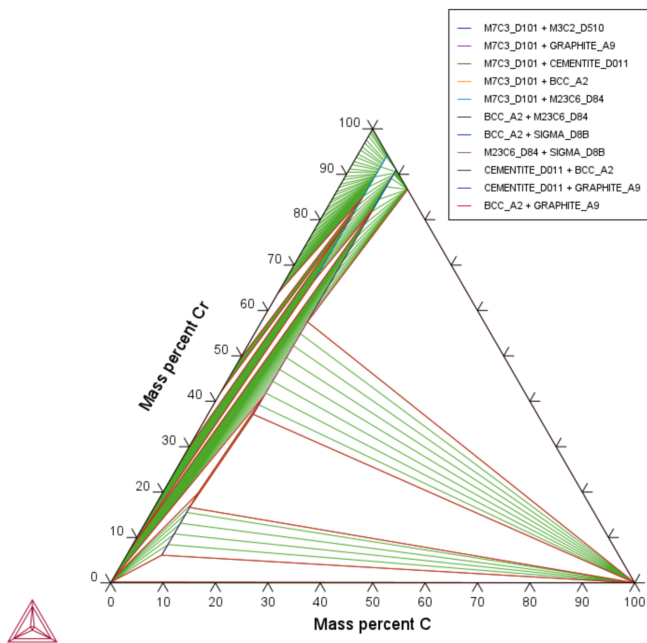

Figure 6: Equilibrium Calculator.

T_05: Stable and the Metastable Fe-C Phase Diagrams

This example shows how to overlay results from two calculations in the same plot using the Equilibrium Calculator.

Project File Information

- Folder: **Thermo-Calc**
- File name: *T_05_Fe-C_stable_and_metastable_phase_diagram.tcu*

Visualizations



This example is included as a tutorial on our [website](#) and as part of the Graphical Mode Examples playlist on our [YouTube channel](#).

Open the example project file to review the node setup on the **Project** window and the associated settings on the **Configuration** window for each node. For some types of projects, you can also adjust settings on the **Plot Renderer Configuration** window to preview results before performing the simulation. Click **Perform Tree** to generate plots and tables to see the results on the **Visualizations** window.

1. The Plot Renderer activity is first created as a successor to Equilibrium Calculator 1.
2. Then right-click the **Plot Renderer** node and select **Add predecessor** and the results from both equilibrium calculators are in the same plot. In **Equilibrium Calculator 1** the stable phase diagram is calculated and in **Equilibrium Calculator 2** the metastable phase.
3. The metastable diagram is obtained by deselecting checkboxes for the GRAPHITE_A9 and DIAMOND_A4 phases on the **Metastable Phases** node (System Definer 2) → **Phases and Phase Constitution** tab.



To make it easier to work with your project, right-click any node and select **Rename**. In this example, System Definer 1 is renamed to **Stable System** and System Definer 2 is renamed to **Metastable System**.

Phases and Phase Constitution		
Status	Name ^	FEDEMO
Entered	BCC_A2	<input checked="" type="checkbox"/>
Entered	C14_LAVES	<input checked="" type="checkbox"/>
Entered	CBCC_A12	<input checked="" type="checkbox"/>
Entered	CEMENTITE_D...	<input checked="" type="checkbox"/>
Entered	CUB_A13	<input checked="" type="checkbox"/>
Entered	DIAMOND_A4	<input type="checkbox"/>
Entered	FCC_A1	<input checked="" type="checkbox"/>
Entered	GAS	<input checked="" type="checkbox"/>
Entered	GRAPHITE_A9	<input type="checkbox"/>
Entered	HCP_A3	<input checked="" type="checkbox"/>

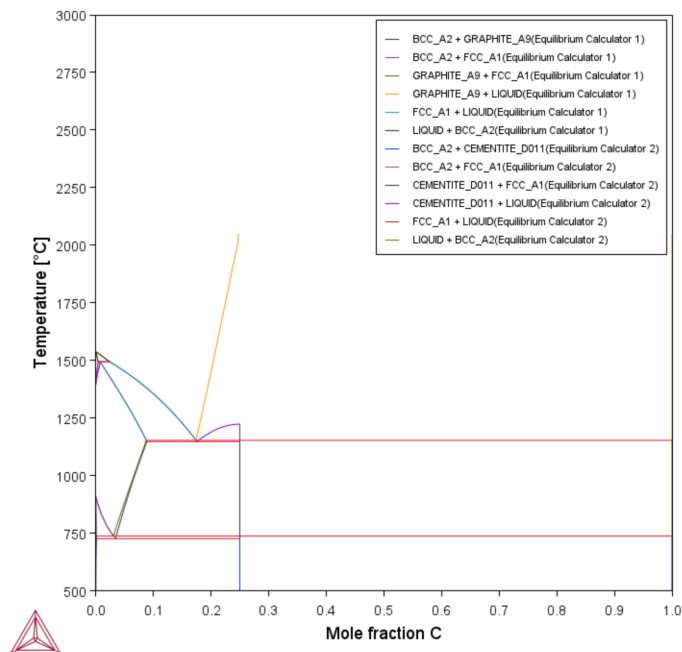

T_06: Serially Coupled Equilibrium Calculators

Sometimes there are multiple solutions for a given set of equilibrium conditions. In other cases the equilibrium calculation does not converge. You can then aid the final calculation by, in effect, telling the software where it should start the search for the equilibrium.

This example shows how to serially couple two Equilibrium Calculator nodes together for more complex equilibrium conditions. For each calculation, the output is to a Table Renderer.

Project File Information

- Folder: **Thermo-Calc**
- File name: *T_06_Serial_equilibrium_calculators.tcu*

Table Renderer Results



This example is included as a tutorial on our [website](#) and as part of the Graphical Mode Examples playlist on our [YouTube channel](#).

Open the example project file to review the node setup on the **Project** window and the associated settings on the **Configuration** window for each node. For some types of projects, you can also adjust settings on the **Plot Renderer Configuration** window to preview results before performing the simulation. Click **Perform Tree** to generate plots and tables to see the results on the **Visualizations** window.

Equilibrium Calculator 1

In the first example, the objective is to calculate the equilibrium at 850° C where the mole fractions of the FCC A1 and BCC A2 phases are 0.5 each for an Fe-Cr-C steel with 10% chromium. In Equilibrium Calculator 1 a simple set of equilibrium conditions (temperature, pressure, system size and composition) are used to find a carbon content where only the FCC A1 and BCC A2 phases are stable. The results from this preliminary calculation are displayed in Table Renderer 1. Open the example to see the full table.

Visualizations				
Table Renderer 1				
System				
Moles	1.00000			
Mass	55.41634	[g]		
Temperature	1123.15000	[K]		
	0.00040	0.00010	0.00137	-91392.91061
Cr	0.10658	0.10000	0.00235	-56531.30746
Fe	0.89296	0.89990	0.00387	-51859.50665
Stable Phases				
BCC_A2#1	<i>Moles</i>	<i>Mass</i>	<i>Volume Fraction</i>	Composition
	0.76777	42.55315	0.76989	
Composition				
<i>Component</i>	<i>Mole Fraction</i>	<i>Mass Fraction</i>		
FCC_A1#1	<i>Moles</i>	<i>Mass</i>	<i>Volume Fraction</i>	Composition
	0.23223	12.86320	0.23011	
Composition				
<i>Component</i>	<i>Mole Fraction</i>	<i>Mass Fraction</i>		
Fe	0.89669	0.90408		
Cr	0.10185	0.09560		
C	0.00147	0.00032		

Equilibrium Calculator 2, 3, and 4

Click each tab along the top of the **Visualizations** window to view the results associated to **Table Renderer 2**, **Table Renderer 2**, and **Table Renderer 2**.

Visualizations				
Table Renderer 1				
Table Renderer 2				
Table Renderer 3				
Table Renderer 4				

- In Equilibrium Calculator 2 the carbon content equilibrium condition is replaced by the condition that the numbers of moles of the BCC A2 phase should be 0.5. The final result is displayed in Table Renderer 2. In this case, the final objective is to calculate the solidus temperature of an Fe-Cr-C steel with 10% Cr and 0.01% C.
- In Equilibrium Calculator 3 the state at 2000 K is calculated and the result is displayed in Table Renderer 3.
- In Equilibrium Calculator 4 the temperature equilibrium condition is replaced by the condition *Fix phase / liquid / 0.0*, meaning that liquid should be stable in an amount of zero moles, i.e. the solidus temperature. The final result is displayed in Table Renderer 4.

T_07: User-Defined Functions

This example shows how to implement user-defined functions. A series of equilibria for an Fe-Cr-C alloy are calculated by varying temperature between 500 and 3000 K. In the configuration window of the Equilibrium Calculator under the **Functions** tab, two identically meaning functions are defined, *fraction solid* and *f solid*, the values of which are plotted against temperature in two Plot Renderer activities. Functions can be entered in terms of *Quantities* $Q1$, $Q2$, $Q3$ and so forth, or by using the Thermo-Calc syntax.

Project File Information

- Folder: **Thermo-Calc**
- File name: *T_07_User_defined_functions.tcu*

Visualizations



This example is included as a tutorial on our [website](#) and as part of the Graphical Mode Examples playlist on our [YouTube channel](#).

Open the example project file to review the node setup on the **Project** window and the associated settings on the **Configuration** window for each node. For some types of projects, you can also adjust settings on the **Plot Renderer Configuration** window to preview results before performing the simulation. Click **Perform Tree** to generate plots and tables to see the results on the **Visualizations** window.

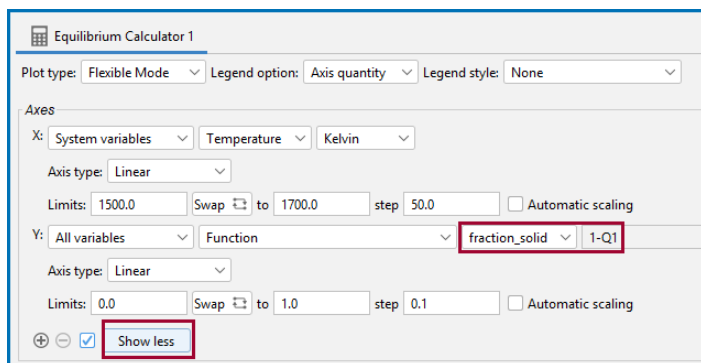

In the **Plot Renderer** settings window, click **Show more** and **Show less** to toggle between viewing all or some of the available settings.

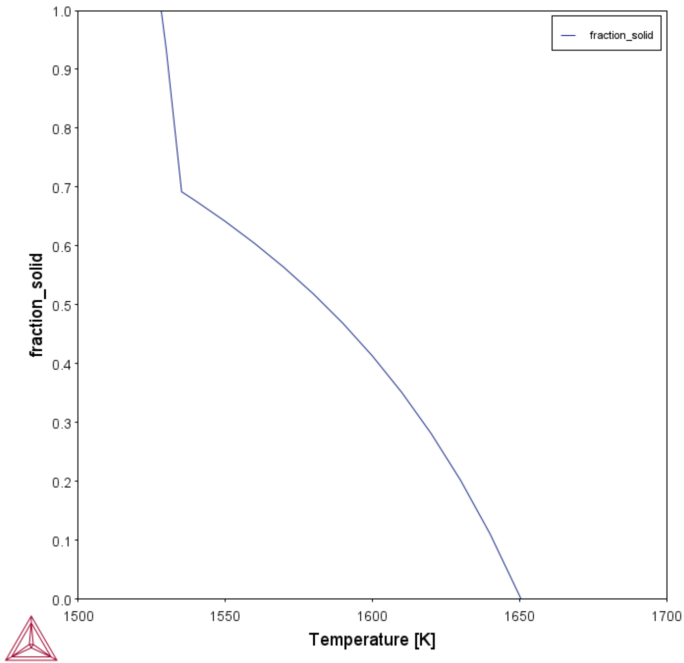

Figure 7: The result of the fraction_solid function.

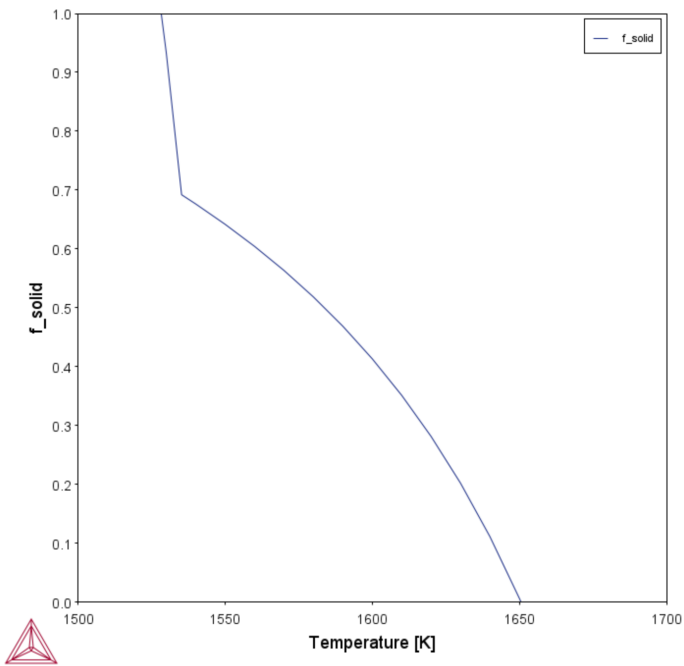

Figure 8: The result of the f_solid function.

T_08: Scheil and Equilibrium Solidification

This example shows a comparison for an Al-Si alloy solidified under full local equilibrium and under the Scheil assumptions, i.e. zero diffusion in the solidified material and infinitely fast diffusion in the liquid. The example uses the Scheil Calculator and adds a Plot Renderer and a Table Renderer.

Project File Information

- Folder: **Thermo-Calc**
- File name: *T_08_Scheil_and_equilibrium_solidification.tcu*

Visualizations



This example is included as a tutorial on our [website](#) and as part of the Scheil Solidification Simulations playlist on our [YouTube channel](#).

Open the example project file to review the node setup on the **Project** window and the associated settings on the **Configuration** window for each node. For some types of projects, you can also adjust settings on the **Plot Renderer Configuration** window to preview results before performing the simulation. Click **Perform Tree** to generate plots and tables to see the results on the **Visualizations** window.

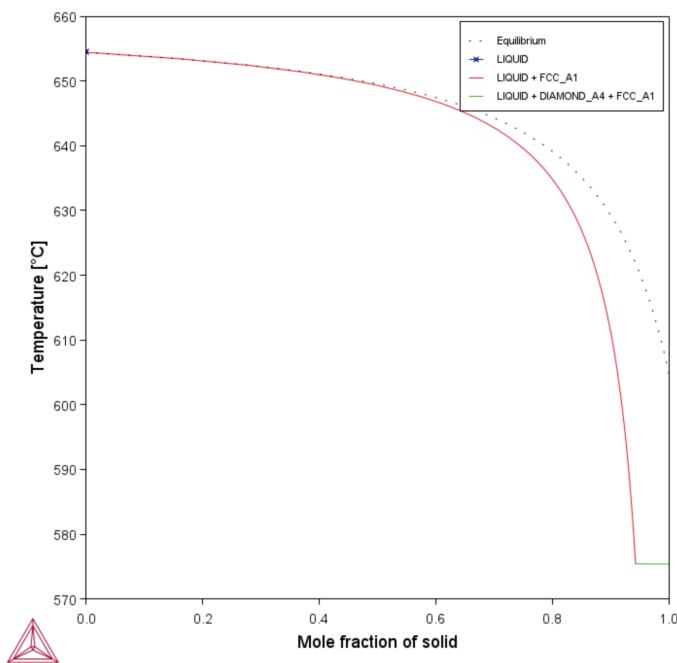
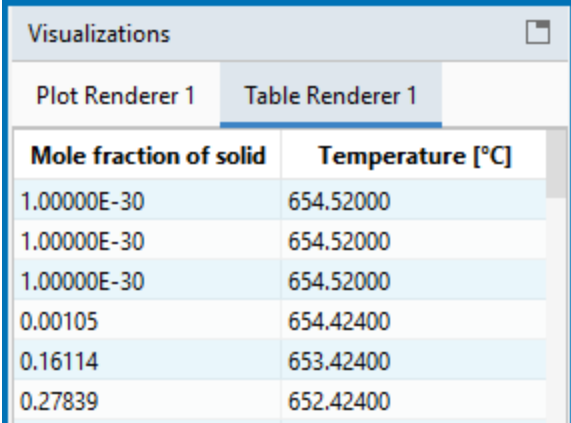

Figure 9: The plot compares the mole fraction of a solid vs temperature.



Mole fraction of solid	Temperature [°C]
1.00000E-30	654.52000
1.00000E-30	654.52000
1.00000E-30	654.52000
0.00105	654.42400
0.16114	653.42400
0.27839	652.42400

Figure 10: The table provides the data, which you can also export.

Saving the Table (via Table Renderer)

There are different ways to save the table from the Table Renderer **Visualizations** or **Configuration** windows.



For the Plot Renderer, there is an option to use the  **Table View** button to convert plots to table data for all calculation types and calculators.

Method 1

In the **Visualizations** window, right click the table and select **Save As...**

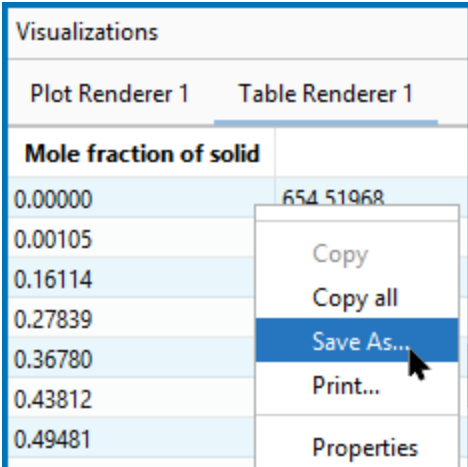

Mole fraction of solid	Temperature [°C]
0.00000	654.51968
0.00105	
0.16114	
0.27839	
0.36780	
0.43812	
0.49481	

- Copy
- Copy all
- Save As...
- Print...
- Properties

Method 2

1. In the **Project** window, click the **Table Renderer**.
2. In the **Configuration** window, click the  **Save table** button .

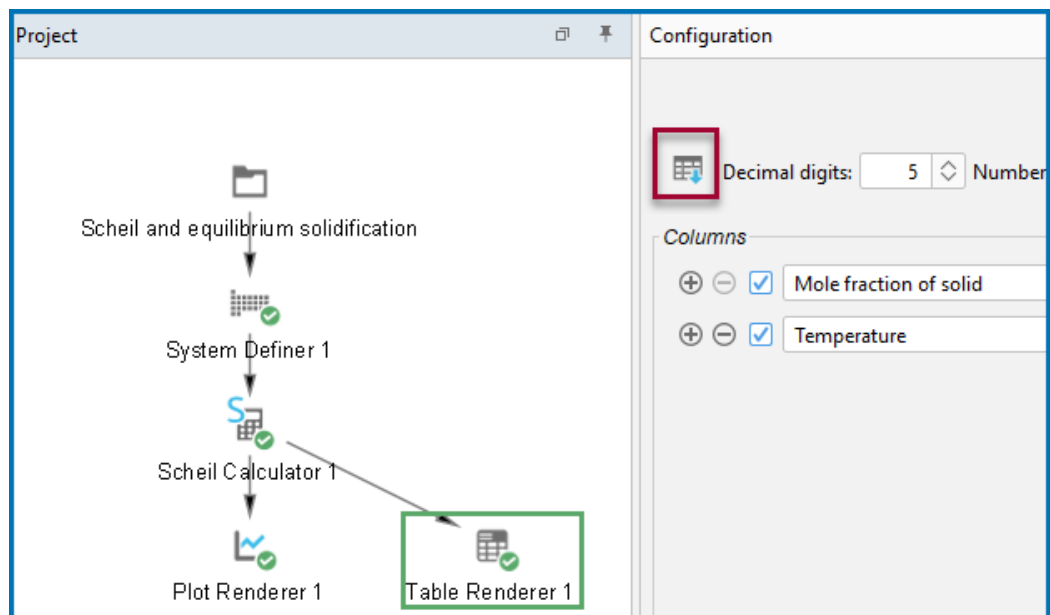

The screenshot displays the Thermo-Calc software interface, divided into two main panels: **Project** and **Configuration**.

Project Panel: Shows a workflow diagram with the following components from top to bottom:

- Scheil and equilibrium solidification (represented by a folder icon)
- System Definer 1 (represented by a grid icon with a green checkmark)
- Scheil Calculator 1 (represented by a blue 'S' icon with a green checkmark)
- Plot Renderer 1 (represented by a line graph icon with a green checkmark)
- Table Renderer 1 (represented by a table icon with a green checkmark, highlighted with a green box)

Configuration Panel: Shows settings for the selected **Table Renderer 1**.

- A red box highlights the **Save table** button (a table icon with a blue arrow) in the top left corner.
- The **Decimal digits** field is set to **5**.
- The **Columns** section lists two columns:
 - Mole fraction of solid
 - Temperature

T_09: Carbide Driving Force Heat Map

This is an example of using **Grid** calculations to plot the driving force for a carbide as a function of two composition variables. With the **Grid Calculation Type**, a 2D grid is generated from the two calculation axes. After the calculation is done, an equilibrium is calculated in each grid point. A Plot Renderer connected to a grid calculation plots the Z-axis property for each equilibrium as a function of the two calculation axes. You can choose different *Plot types* such as **Heat map**, **Contour**, and **3D** to display the results.



In the **Plot Renderer** settings window, click **Show more** and **Show less** to toggle between viewing all or some of the available settings.

Project File Information

- Folder: **Thermo-Calc**
- File name: *T_09_Heat_map_of_carbide_driving_force.tcu*

Visualizations



This example is included as a tutorial on our [website](#) and as part of the Graphical Mode Examples playlist on our [YouTube channel](#).

Open the example project file to review the node setup on the **Project** window and the associated settings on the **Configuration** window for each node. For some types of projects, you can also adjust settings on the **Plot Renderer Configuration** window to preview results before performing the simulation. Click **Perform Tree** to generate plots and tables to see the results on the **Visualizations** window.

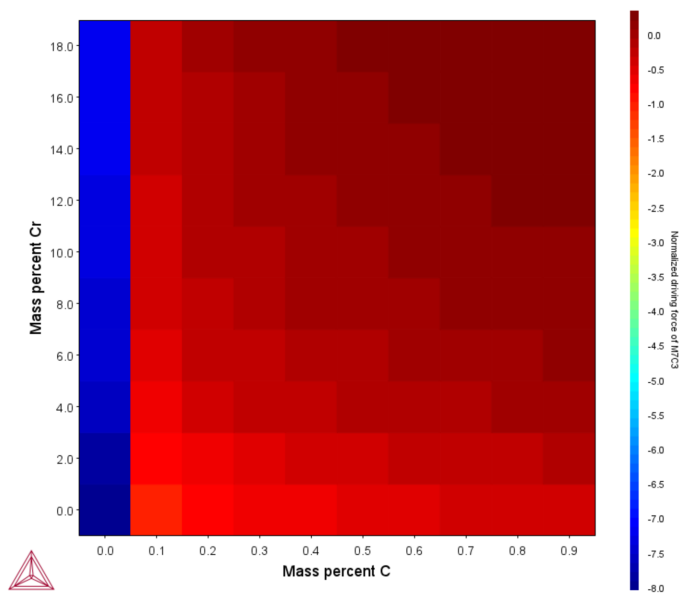

Figure 11: The results are plotted as a Heat map. Alternatively, a Contour Plot type can be selected on the Plot Renderer.

T_10: Scheil Solidification with Back Diffusion

This is an example of a Scheil solidification simulation of a Al-2.1Cu-1Si alloy including back diffusion in the primary phase.

The example uses two of the Scheil Calculator activity nodes with different cooling rates, 10 K/s and 0.005 K/s. The lower cooling rate produces a solidification curve that is closer to the equilibrium curve as shown in the plot result. Both a thermodynamic ALDEMO (aluminum demo) and mobility MALDEMO (Al-alloys mobility) database are used for this calculation.

Project File and License Information

- Folder: **Thermo-Calc**
- File name: *T_10_Scheil_with_back_diffusion.tcu*



The Scheil with back diffusion feature is only available for systems with diffusion data, i.e. this model requires the use of a mobility database.



Running the example itself does not require an additional license.

Visualizations



This example is included as a tutorial on our [website](#) and as part of the Scheil Solidification Simulations playlist on our [YouTube channel](#).

Open the example project file to review the node setup on the **Project** window and the associated settings on the **Configuration** window for each node. For some types of projects, you can also adjust settings on the **Plot Renderer Configuration** window to preview results before performing the simulation. Click **Perform Tree** to generate plots and tables to see the results on the **Visualizations** window.

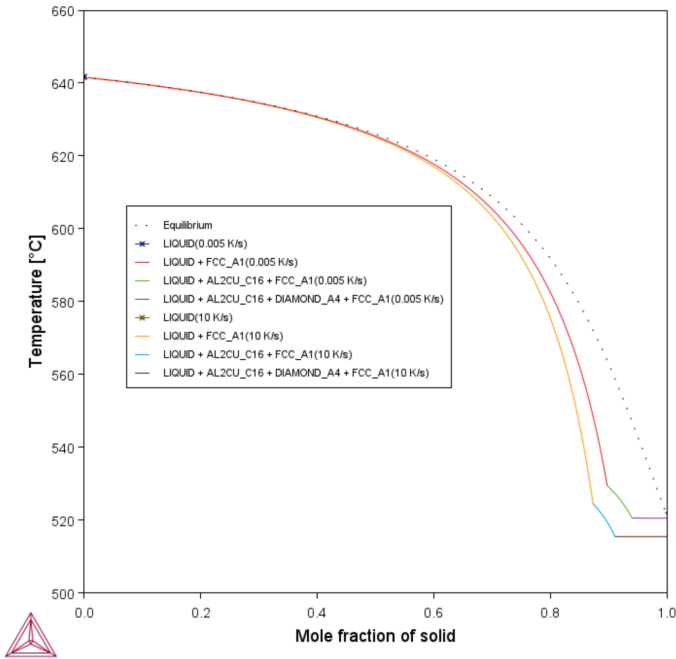

Figure 12: Scheil solidification. The lower cooling rate produces a solidification curve that is closer to the equilibrium curve.

T_11: Surface Tension in Cu-Zr

This is an example of including surface tension in the calculations.

Using the ALDEMO database, which is the free demonstration version of the TCS AI-based Alloy Database (TCAL), the surface tension of liquid metallic is plotted at 1373 K for Cu-Zr and compared to experimental data from [2005Kra].

Reference

[2005Kra] V. P. Krasovskyy, Y. V. Naidich, N. A. Krasovskaya, Surface tension and density of copper–Zirconium alloys in contact with fluoride refractories, *J. Mater. Sci.* 40, 2367–2369 (2005).

Project File Information

- Folder: **Thermo-Calc**
- File name: *T_11_Surface_tension_in_Cu-Zr.tcu*



The same example is also provided in Console Mode as `tcex56`.

Visualizations



Many of our Graphical Mode examples have video tutorials, which you can access in a variety of ways. When in Thermo-Calc, from the menu select **Help** → **Video Tutorials**, or from the main My Project window, click **Video Tutorials**. Alternately, you can go to the [website](#) or our [YouTube channel](#).

Open the example project file to review the node setup on the **Project** window and the associated settings on the **Configuration** window for each node. For some types of projects, you can also adjust settings on the **Plot Renderer Configuration** window to preview results before performing the simulation. Click **Perform Tree** to generate plots and tables to see the results on the **Visualizations** window.

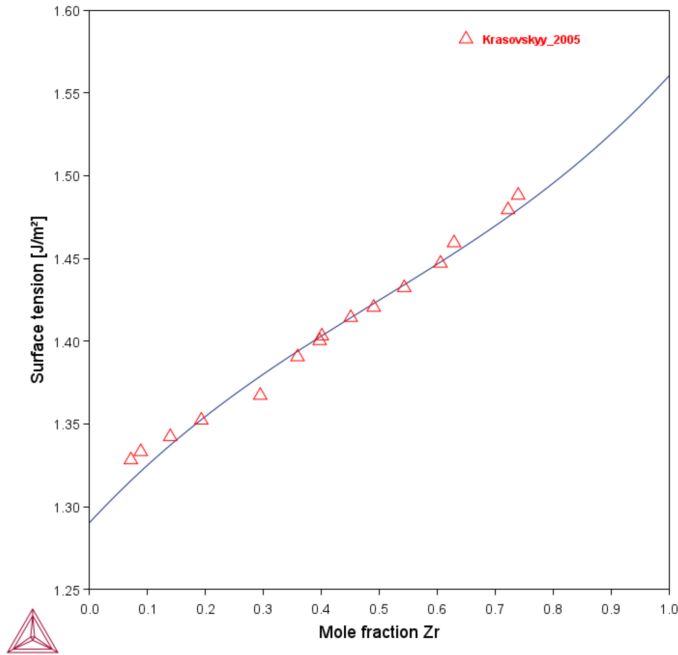

Figure 13: Surface tension of liquid metallic at 1373 K for Cu-Zr and compared to experimental data from [2005Kra].

More Information

The thermophysical properties are progressively being added to the Thermo-Calc databases starting with Thermo-Calc software version 2020a.



You can learn more about the models by searching the help (press F1 when in Thermo-Calc).



You can find information on our website about the [properties that can be calculated](#) with Thermo-Calc and the Add-on Modules.

T_12: Viscosity in Cr-Ni

This is an example of including viscosity in the calculations.

Using the FEDEMO database, which is the free demonstration version of the TCS Steel and Fe-alloys Database (TCFE), the viscosity of metallic liquids is plotted at 1873 K for Cu-Ni and compared to experimental data from [2005Sat].

Reference

[2005Sat] Y. Sato, K. Sugisawa, D. Aoki, T. Yamamura, Viscosities of Fe–Ni, Fe–Co and Ni–Co binary melts, Meas. Sci. Technol. 16, 363–371 (2005).

Project File Information

- Folder: **Thermo-Calc**
- File name: *T_12_Viscosity_in_Cr-Ni.tcu*



The same example is also provided in Console Mode as `tcex55`.

Visualizations



Many of our Graphical Mode examples have video tutorials, which you can access in a variety of ways. When in Thermo-Calc, from the menu select **Help** → **Video Tutorials**, or from the main My Project window, click **Video Tutorials**. Alternately, you can go to the [website](#) or our [YouTube channel](#).

Open the example project file to review the node setup on the **Project** window and the associated settings on the **Configuration** window for each node. For some types of projects, you can also adjust settings on the **Plot Renderer Configuration** window to preview results before performing the simulation. Click **Perform Tree** to generate plots and tables to see the results on the **Visualizations** window.

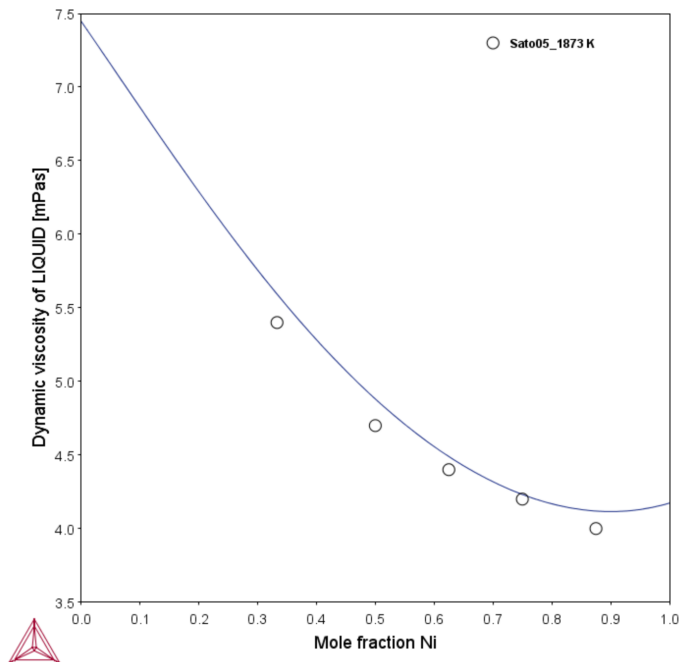

Figure 14: The viscosity of metallic liquids at 1873 K for Cu-Ni and compared to experimental data from [2005Sat].

More Information

The thermophysical properties are progressively being added to the Thermo-Calc databases starting with Thermo-Calc software version 2020a.



You can learn more about the models by searching the help (press F1 when in Thermo-Calc).



You can find information on our website about the [properties that can be calculated](#) with Thermo-Calc and the Add-on Modules.

T_13: Scheil Solidification with Solute Trapping

In Graphical Mode, you use the **Scheil Calculator** to set up the various Scheil solidification simulations.

This example shows the use of the *Scheil with solute trapping* option with an Al-7.5Si-0.2Cu alloy as compared to a Classic Scheil calculation. The thermodynamic ALDEMO (Aluminum demo) database, available to all users, is selected for this calculation to simulate the effect of solute trapping in the primary phase. This type of simulation is useful for additive manufacturing applications.

This example shows how the alloy starts to solidify at a lower temperature compared to a classic Scheil simulation, an effect which increases with increasing solidification speed. The solidification speed is calculated from user supplied scanning speed and angle between the solid/liquid interface and the scanning direction.

The example uses the **Aziz** model, with an **Interface driving force** of **Migration energy** and a **Maximum velocity for infinite driving force** of 2000 m/s.



Read more about [Scheil Solidification Simulations](#) on our website, including [how to select the right model for your simulation](#). If you are in Thermo-Calc, press F1 to search the help to learn about using Scheil.

Project File Information

- Folder: **Thermo-Calc**
- File name: *T_13_Scheil_with_Solute_Trapping.tcu*

Visualizations



Many of our Graphical Mode examples have video tutorials, which you can access in a variety of ways. When in Thermo-Calc, from the menu select **Help** → **Video Tutorials**, or from the main My Project window, click **Video Tutorials**. Alternately, you can go to the [website](#) or our [YouTube channel](#).

Open the example project file to review the node setup on the **Project** window and the associated settings on the **Configuration** window for each node. For some types of projects, you can also adjust settings on the **Plot Renderer Configuration** window to preview results before performing the simulation. Click **Perform Tree** to generate plots and tables to see the results on the **Visualizations** window.

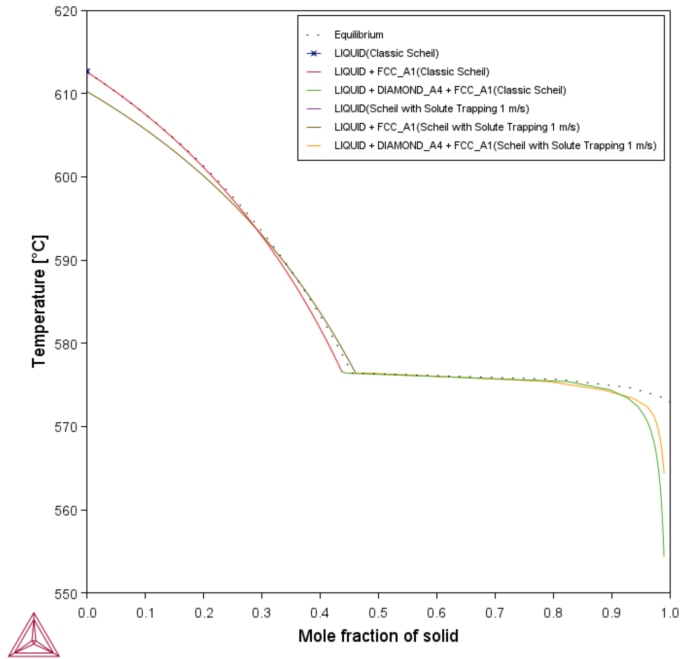

Figure 15: The effect of Scheil solidification with solute trapping of a Al-7.5Si-0.2Cu alloy compared to equilibrium and a Classic Scheil calculation.

T_14: Fe-Cr-Ni Transition Comparison Using the Material to Material Calculator

In Graphical Mode, you use the **Material to Material Calculator** to perform calculations and examine how two materials transition from one into the other. The calculations in this example search for potential deleterious phases during heat treatment of alloys joined together. In this example, the calculation steps between a model martensitic stainless steel (Fe-17Cr-2Ni) and a model Alloy 800 composition (Fe-35Ni-19Cr). Neither alloy is predicted to form the deleterious sigma phase at 600 °C. However sigma is predicted to form at a wide range of mixtures of these two materials, which could have an impact on mechanical properties if it forms.

The example, as defined when you open it, uses a **One Axis** calculation (also known as a property diagram), a temperature of 650 °C, to compare the volume fraction of all phases to the mass fraction of Alloy 800. The **Fraction of the second material** (Alloy 800) is set to 50% (0.5), which for a **One Axis** calculation is used as the start value.



As with all the examples, you can adjust the settings to plot a variety of combinations of output to see how the Material to Material Calculator works before defining your own project.

The plot for this calculation compares the volume fraction of all phases of Material 1 (martensitic stainless steel) to the mass fraction of Material 2 (Alloy 800). In the plots you can see where each phase (FCC_A1, SIGMA_D8B, and BCC_A2) evolves. As you step from Material 1 to Material 2, the FCC_A1 phase starts forming at about 5% (0.05), SIGMA-D8B phase starts to evolve at about 19% (0.19), and the BCC_A2 transitions from Material 1 to Material 2 where it stops forming at approximately 24% (0.24). The purpose of the calculation is to determine at what fraction of Alloy 800 the deleterious sigma phase forms and this is shown for these compositions.

Project File Information

- Folder: **Thermo-Calc**
- File name: *T_14_Fe-Cr-Ni_Material_to_Material.tcu*

Visualizations



This example is included as a tutorial on our [website](#) and as part of the Graphical Mode Examples playlist on our [YouTube channel](#).

Open the example project file to review the node setup on the **Project** window and the associated settings on the **Configuration** window for each node. For some types of projects, you can also adjust settings on the **Plot Renderer Configuration** window to preview results before performing the simulation. Click **Perform Tree** to generate plots and tables to see the results on the **Visualizations** window.



In the **Plot Renderer** settings window, click **Show more** and **Show less** to toggle between viewing all or some of the available settings.

The default plot shows the volume fraction of all phases as a function of the mass fraction of the second material, which in this case, is Alloy 800. You can see that the martensitic stainless composition is BCC at this temperature, and the highly alloyed stainless is FCC. Neither material is expected to form any deleterious phase on its own at 650 °C.

However, mixtures of these two materials, which could arise from a graded transition joint, weld, or potentially a diffusion couple, show some stability for the deleterious sigma phase at this temperature. You can try to make small adjustments to the initial chemistry to reduce the potential for sigma phase to form.

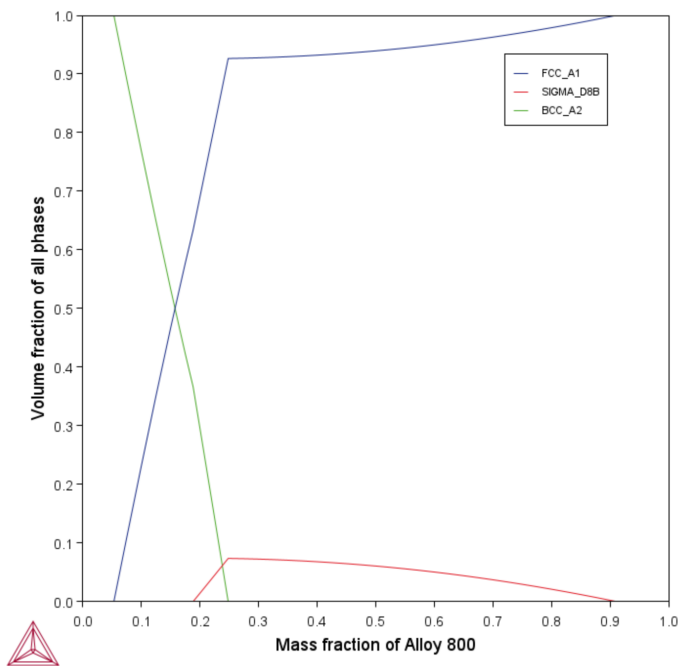

Figure 16: This plot shows the volume fraction of phases when changing composition from the Martensitic Steel (First material) to the Alloy 800 (Second material). This calculation uses the Material to Material Calculator to examine the transition of phases for two compositions of Fe-Cr-Ni. The purpose is to determine at what fraction of Alloy 800 does the deleterious sigma phase start to form. See the text for details.

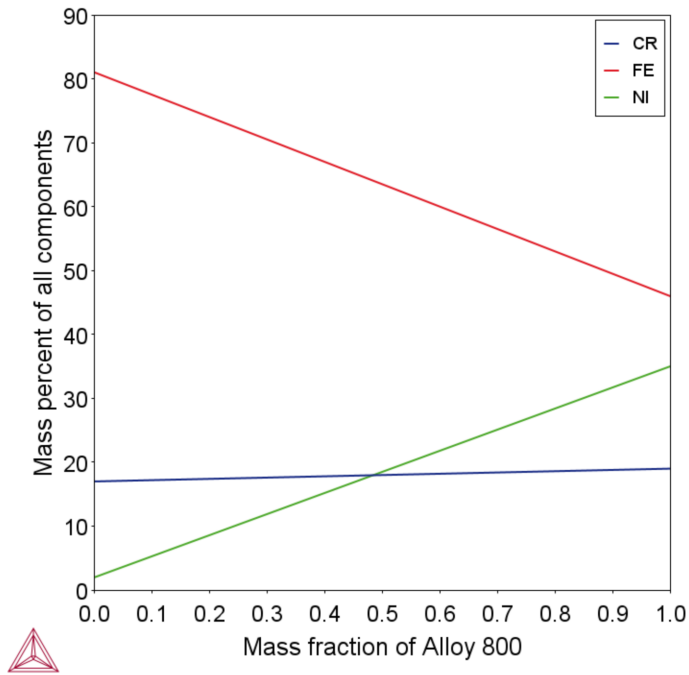

Figure 17: The composition varies linearly when the composition is changed from the Martensitic steel to the Alloy 800 using the Material to Material Calculator. See the text for details.

T_15: Molar Volume and Thermal Expansion Coefficients for L12-type Al₃Sc and Al₃Zr Compounds

This example calculates volumetric thermal expansion coefficients of the L12-type Al₃Sc and the L12-type Al₃Zr, respectively. Both Al₃Zr and Al₃Sc are modeled as the same phase (named as AL3SC, since Al₃Sc is stable while Al₃Zr is metastable).

The example uses two System Definers and Equilibrium Calculators to plot and compare the molar volume and thermal expansion coefficients of the Al₃Sc and Al₃Zr binary compounds. It uses the ALDEMO database, which is the free demonstration version of the TCS Al-based Alloy Database (TCAL) and an Experimental File Reader node to read the data from [2015Sah].

Project File Information

- Folder: **Thermo-Calc**
- File name: *T_15_Molar_Volume_and_Thermal_Expansion_Coefficient.tcu*

The example includes an experimental data (*.exp) file called Al₃X.exp.



The same example is also provided in Console Mode as two separate examples: tcex58 and tcex59.

Visualizations



Many of our Graphical Mode examples have video tutorials, which you can access in a variety of ways. When in Thermo-Calc, from the menu select **Help** → **Video Tutorials**, or from the main My Project window, click **Video Tutorials**. Alternately, you can go to the [website](#) or our [YouTube channel](#).

Open the example project file to review the node setup on the **Project** window and the associated settings on the **Configuration** window for each node. For some types of projects, you can also adjust settings on the **Plot Renderer Configuration** window to preview results before performing the simulation. Click **Perform Tree** to generate plots and tables to see the results on the **Visualizations** window.

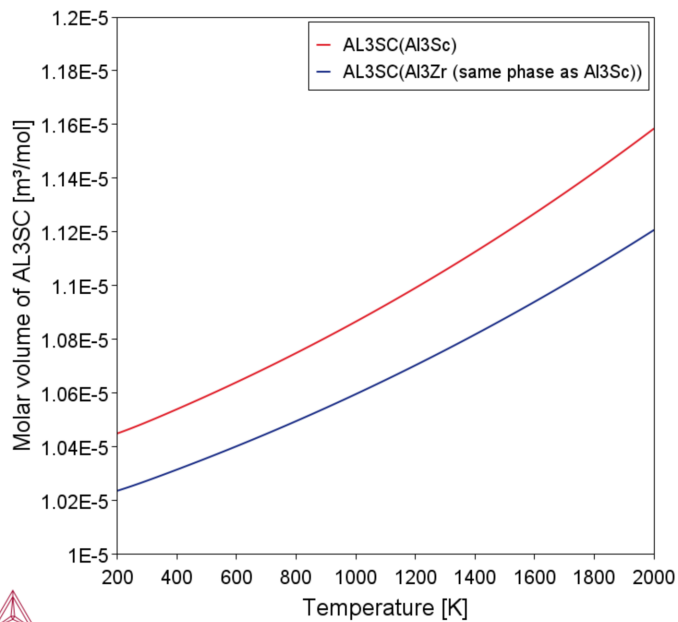

Figure 18: Compares the molar volume of both Al3Zr and Al3Sc, which are modeled as the same phase (named as AL3SC, since Al3Sc is stable while Al3Zr is metastable).

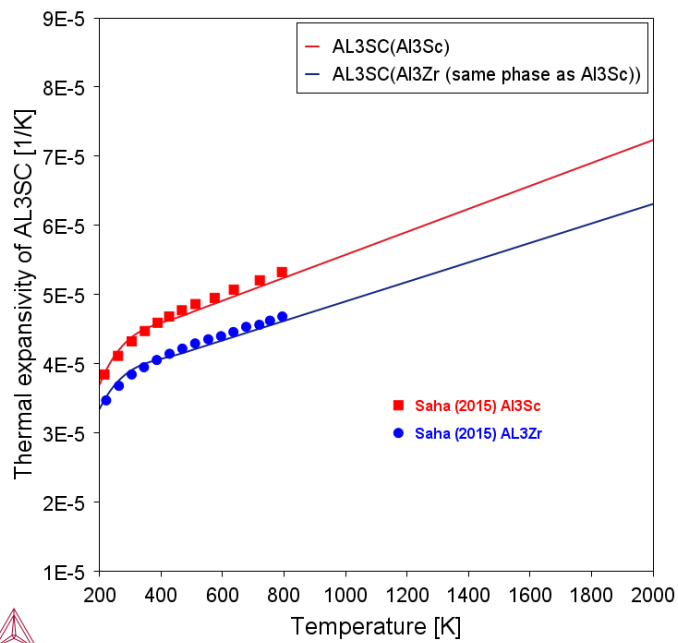

Figure 19: Compares volumetric thermal expansion coefficients of the L12-type Al3Sc and the L12-type Al3Zr using theoretical data with quasiharmonic approximation from [2015Sah].

Reference

[2015Sah] S. Saha, T. Z. Todorova, J. W. Zwanziger, Temperature dependent lattice misfit and coherency of Al₃X (X=Sc, Zr, Ti and Nb) particles in an Al matrix. Acta Mater. 89, 109–115 (2015).

More Information

The thermophysical properties are progressively being added to the Thermo-Calc databases starting with Thermo-Calc software version 2020a.



You can learn more about the models by searching the help (press F1 when in Thermo-Calc).



You can find information on our website about the [properties that can be calculated](#) with Thermo-Calc and the Add-on Modules.

T_16: Electrical Resistivity and Thermal Conductivity for Pure Copper

This example calculates the electrical resistivity (ELRS) and thermal conductivity (THCD) of pure Cu. It makes a *One Axis* (step) calculation over a wide temperature range, covering both the FCC_A1 state and the liquid state. It plots thermal conductivity of the system (both FCC_A1 and liquid) and that of a single phase (taking FCC_A1 as an example), respectively. Also it plots electrical resistivity of the system and that of FCC_A1.

The example set up uses an Equilibrium Calculator combined with four Experimental File Reader nodes that take data from the included 1972Ho_cu_thcd.exp and 1981Ho_cu_elrs.exp files.



The example is available to all users as it uses the ALDEMO database, which is the free demonstration version of the TCS AI-based Alloy Database (TCAL).

Project File Information

- Folder: **Thermo-Calc**
- File name: *T_16_Electrical_Resistivity_Thermal_Conductivity_Cu.tcu*
- Experimental data files included 1972Ho_cu_thcd.exp and 1981Ho_cu_elrs.exp



The same example is also provided in Console Mode as `tcex60`.

Visualizations



This example is included as a tutorial on our [website](#) and as part of the Graphical Mode Examples playlist on our [YouTube channel](#).

Open the example project file to review the node setup on the **Project** window and the associated settings on the **Configuration** window for each node. For some types of projects, you can also adjust settings on the **Plot Renderer Configuration** window to preview results before performing the simulation. Click **Perform Tree** to generate plots and tables to see the results on the **Visualizations** window.

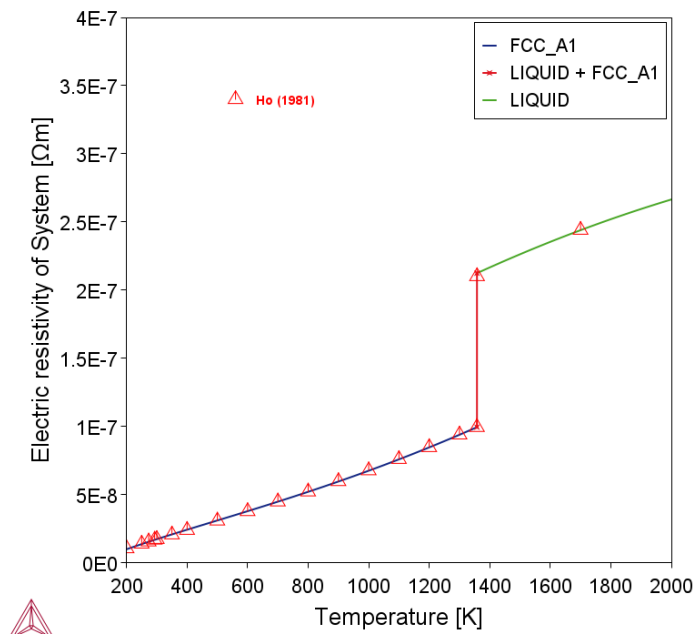

Figure 20: The electrical resistivity (ELRS) of pure Cu over a wide temperature range, covering both the FCC_A1 state and the liquid state. The data was recommended by [1981Ho].

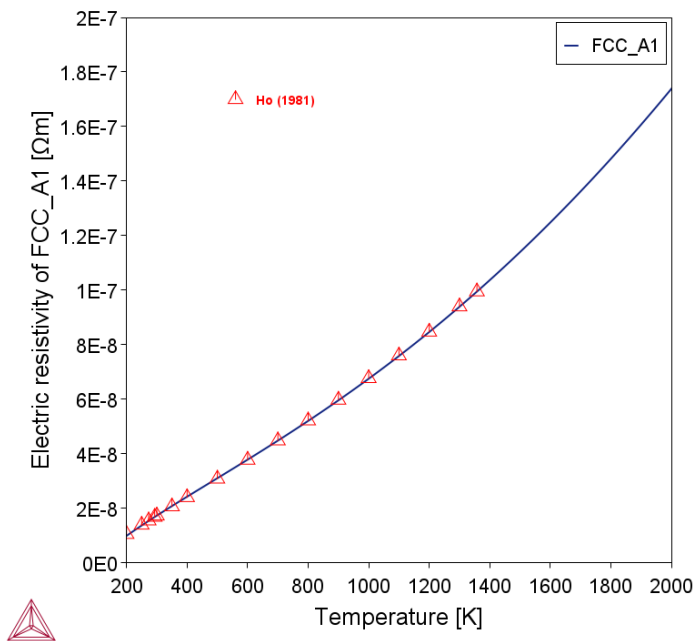

Figure 21: The electrical resistivity (ELRS) of a single phase (FCC_A1) vs. temperature. The data was recommended by [1981Ho].

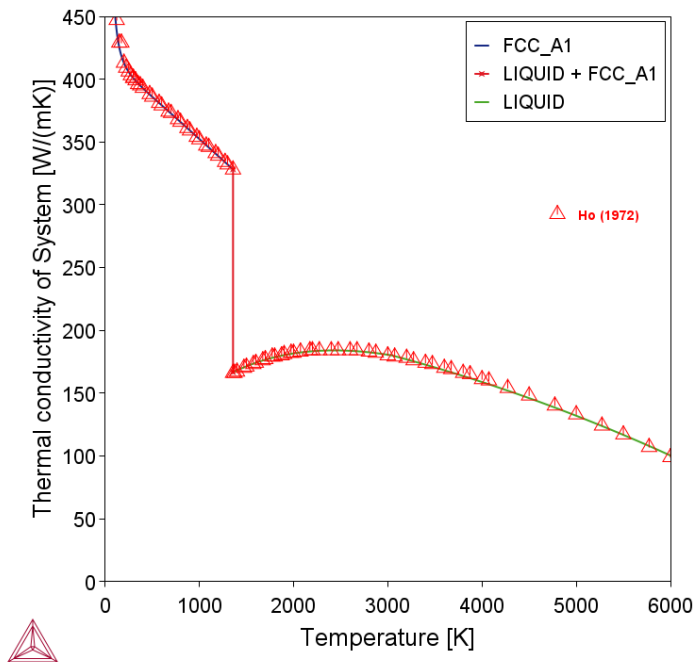

Figure 22: The thermal conductivity of pure Cu over a wide temperature range, covering both the FCC_A1 state and the liquid state. The data was recommended by [1972Ho].

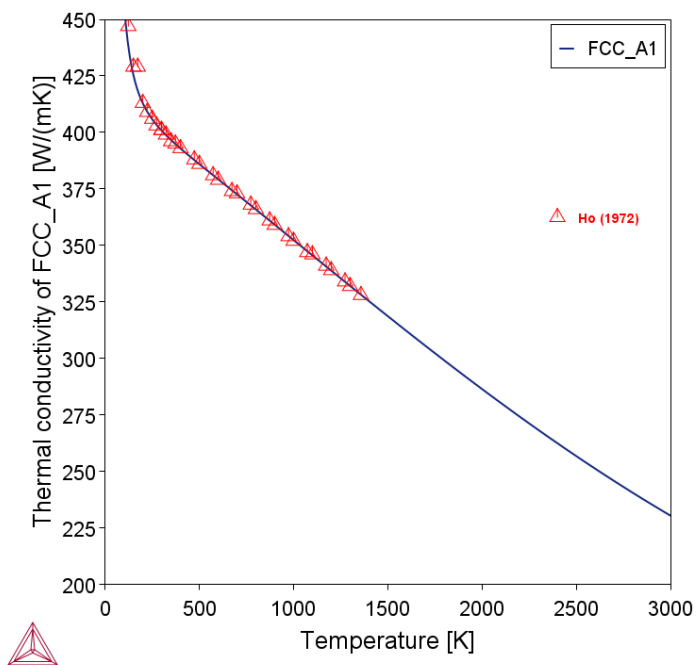

Figure 23: The thermal conductivity (THCD) of a single phase (FCC_A1) vs. temperature. The data was recommended by [1972Ho].

References

[1972Ho] C. Y. Ho, R. W. Powell, P. E. Liley, Thermal Conductivity of the Elements. J. Phys. Chem. Ref. Data. 1, 279–421 (1972).

[1981Ho] C. Y. Ho, M. W. Ackerman, K. Y. Wu, T. N. Havill, R. H. Bogaard, R. A. Matula, S. G. Oh, and H. M. James. Electrical resistivity of ten selected binary alloy systems. CINDAS report 59, for Office of standard reference data National Bureau of Standards, Department of Commerce (1981).

More Information



For more advanced examples using the TCAL database, see "[PM_G_10: Freeze-in Thermal Conductivity](#)" on page 86 and "[PM_G_11: Freeze-in Electrical Resistivity](#)" on page 88.

The thermophysical properties are progressively being added to the Thermo-Calc databases starting with Thermo-Calc software version 2020a.



You can learn more about the models by searching the help (press F1 when in Thermo-Calc).



You can find information on our website about the [properties that can be calculated](#) with Thermo-Calc and the Add-on Modules.

T_17: Al₂O₃-MgO Phase Diagram

Al₂O₃-MgO is one of the basic systems to understand metallurgical slags and refractories. This example uses an Equilibrium Calculator to calculate a phase diagram of the pseudo-binary system Al₂O₃-MgO. It also demonstrates how to change components in the System Definer. In this case, the components Al₂O₃ and MgO are defined instead of the elements Al, Mg, and O.



In the **Plot Renderer** settings window, click **Show more** and **Show less** to toggle between viewing all or some of the available settings.

Project File and License Information

- Folder: **Thermo-Calc**
- File name: *T_17_Al2O3-MgO_phase_diagram.tcu*



The TCS Metal Oxide Solutions Database (TCOX) is used in this example. A valid license for version 11 (TCOX11) or newer is required to run the example.

Visualizations



This example is included as a tutorial on our [website](#) and as part of the Graphical Mode Examples playlist on our [YouTube channel](#).

Open the example project file to review the node setup on the **Project** window and the associated settings on the **Configuration** window for each node. For some types of projects, you can also adjust settings on the **Plot Renderer Configuration** window to preview results before performing the simulation. Click **Perform Tree** to generate plots and tables to see the results on the **Visualizations** window.

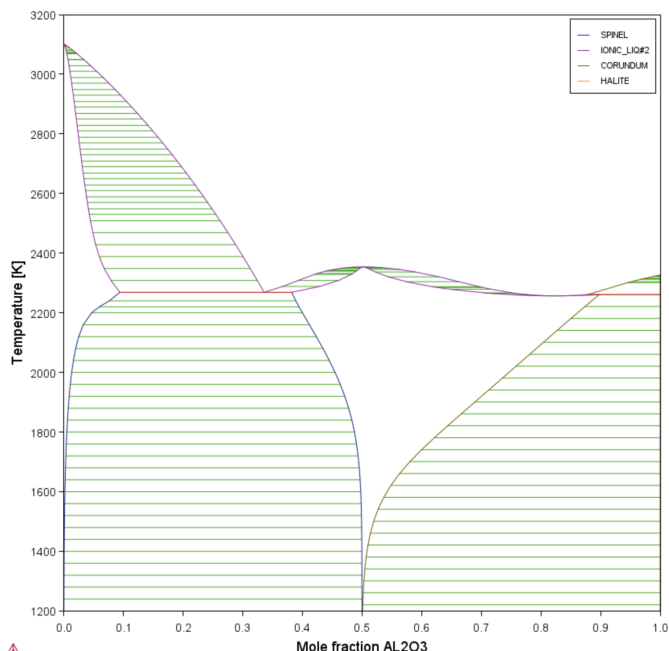

Figure 24: Phase diagram of the pseudo-binary system Al_2O_3 - MgO .

More Information



This example is also included in the *TCS Metal Oxide Solutions Database (TCOX) Validation and Calculation Examples Collection*.



There is a similar example provided in Console Mode that uses the OXDEMO database, which is available to all users. See `tcex17`.



Go to the [Metal Slag and Oxides Database](#) page on our website where you can access a Validation and Calculation Examples Collection and the Technical Information plus learn about its many applications with the [Process Metallurgy Module](#). Also explore further applications of Thermo-Calc to [Refractory Oxides](#) and [Slags](#) including links to resources such as examples, publications, and more.

T_18: Scheil with Delta Ferrite to Austenite Transition

This is an example of a Scheil solidification simulation using an Fe-0.23C-0.19Si-0.47Mn-0.92Cr-0.09Ni-0.3Mo (wt%) alloy (Steel P) [2015Sch], which is a steel that undergoes the peritectic transformation.

The result of a Scheil Calculator with the default **Classic Scheil** calculation type is compared to the result of a calculator where the setting **Allow delta ferrite to austenite transition in steel** is selected. Carbon (C) is set as a **Fast diffuser** in both. A comparison to experimental solidus temperature from Schaffnit et al. [2015Sch] shows that for this steel, using the **Allow delta ferrite to austenite transition in steel** option gives a much better agreement with experiment than the standard **Classic Scheil**.

Project File and License Information

- Folder: **Thermo-Calc**
- File name: *T_18_Scheil_with_Delta_Ferrite_to_Austenite_Transition.tcu*



This uses the TCFE database. A license is required to run the example.

Visualizations



Many of our Graphical Mode examples have video tutorials, which you can access in a variety of ways. When in Thermo-Calc, from the menu select **Help → Video Tutorials**, or from the main My Project window, click **Video Tutorials**. Alternately, you can go to the [website](#) or our [YouTube channel](#).

Open the example project file to review the node setup on the **Project** window and the associated settings on the **Configuration** window for each node. For some types of projects, you can also adjust settings on the **Plot Renderer Configuration** window to preview results before performing the simulation. Click **Perform Tree** to generate plots and tables to see the results on the **Visualizations** window.

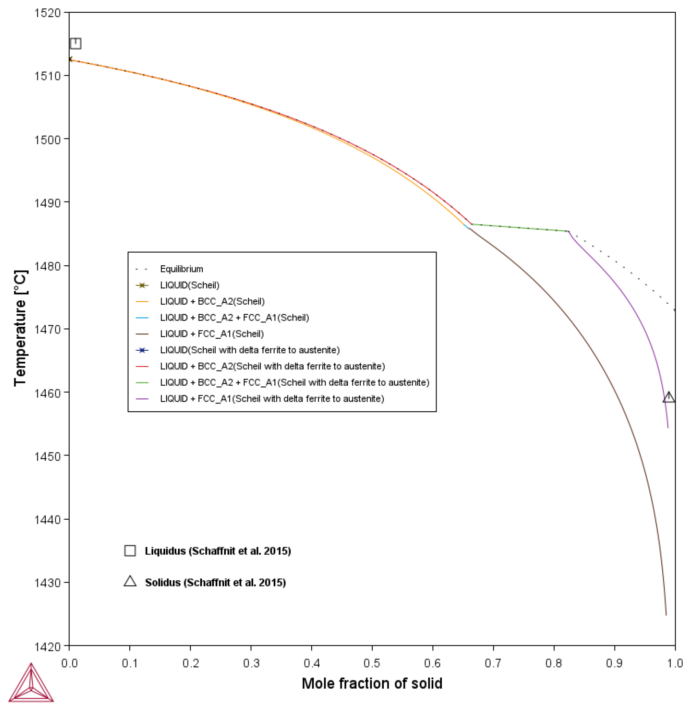

Figure 25: Mole fraction of solid as a function of temperature comparing the liquidus and solidus from experimental data [2015Sch].

Reference

[2015Sch] P. Schaffnit, C. Stallybrass, J. Konrad, F. Stein, M. Weinberg, A Scheil–Gulliver model dedicated to the solidification of steel. *Calphad*. 48, 184–188 (2015).

T_19: Young's Modulus for Ti-O with Elastic Properties

This is an example which shows the effect of oxygen concentration at three temperatures on an elastic property, Young's modulus, for the HCP_A3 phase in a Ti-O system.

It is well established in the literature that mechanical properties of titanium and its related alloys are sensitive to the presence of even dilute concentrations of interstitial solutes such as carbon, hydrogen, nitrogen and oxygen. It is therefore important to adequately model the effects of impurities in the host lattice when calculating mechanical properties, such as the elastic constants and the corresponding moduli determined from these constants.



Only the elastic constants are assessed, and then used to derive the elastic moduli, meaning the experimental data in the plot are completely standalone from the assessment process.

In this example, three **Equilibrium Calculators** are used with **One Axis** calculations at different temperatures (298 K, 533 K, and 672 K) to show the Young's modulus of an HCP_A3 phase as a function of mole percent of O and compared to experimental data from [1957Gra; 1966Fed; 1971Hsu].

Project File and License Information

- Folder: **Thermo-Calc**
- File name: *T_19_Elastic_Properties_YoungsModulus_Ti-O.tcu*



The TCS Ti/TiAl-based Alloys Database (TCTI) is used in this example. A valid license is required to run the example.

Visualizations



Many of our Graphical Mode examples have video tutorials, which you can access in a variety of ways. When in Thermo-Calc, from the menu select **Help** → **Video Tutorials**, or from the main My Project window, click **Video Tutorials**. Alternately, you can go to the [website](#) or our [YouTube channel](#).

Open the example project file to review the node setup on the **Project** window and the associated settings on the **Configuration** window for each node. For some types of projects, you can also adjust settings on the **Plot Renderer Configuration** window to preview results before performing the simulation. Click **Perform Tree** to generate plots and tables to see the results on the **Visualizations** window.

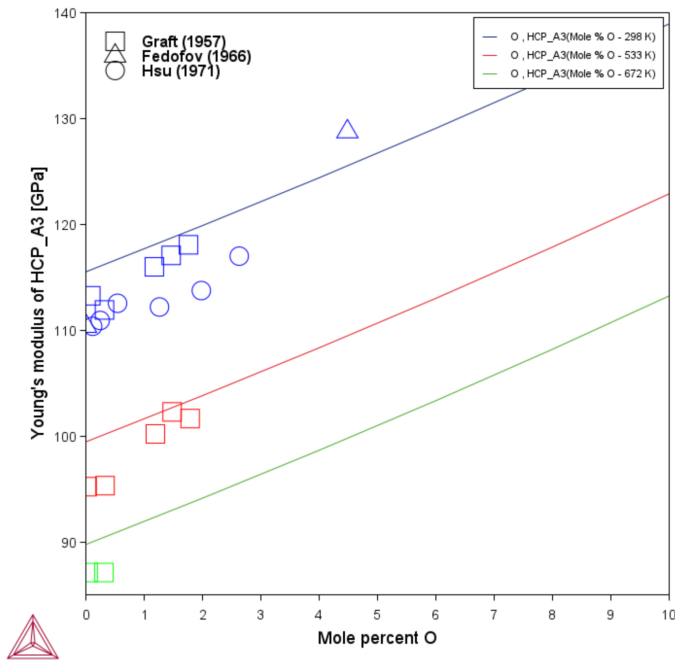

Figure 26: Effect of oxygen on Young's modulus in HCP_A3 titanium compared to experimental data [1957Gra; 1966Fed; 1971Hsu].

References

- [1957Gra] W. H. Graft, D. W. Levinson and W. Rostoker, The influence of alloying on the elastic modulus of titanium alloys, *Trans. Am. Soc. Met.* 49, 263-279 (1957).
- [1966Fed] S. G. Fedofov, *Titanium and Its Alloys*, Publ. No. IO, I. I. Kornilov Editor, Israel Prog. Sci. Trans., 199 (1966).
- [1971Hsu] N. Hsu, H. Conrad, Ultrasonic wave velocity measurements on titanium-oxygen alloys. *Scr. Metall.* 5, 905–908 (1971).

More Information



As of Thermo-Calc version 2025b, elastic properties are available with Thermo-Calc and the TCS Ti/TiAl-based Alloys Database (TCTI) (TCTI6 and newer), TCS Steel and Fe-alloys Database (TCFE) (TCFE14 and newer), TCS High Entropy Alloys Database (TCHEA) (TCHEA8 and newer), and TCS Ni-based Superalloys Database (TCNI) (TCNI13 and newer). These elastic properties will be added to additional databases over time. [Subscribe to our newsletter](#) to be kept up-to-date on the latest product releases, webinars, user group meetings, applications examples, and more.

T_20: Ternary Diagram with Clockwise Plot Axes

This **Ternary Calculator** example for a Cr-Fe-Ni system shows how to use different plot axis combinations on the **Plot Renderer** representing clockwise and counterclockwise axes. This example uses the FEDEMO database and is available to all users.

A ternary phase diagram is fully defined by the elements in the corners of the diagram. See [Figure 27](#) for the Cr-Fe-Ni 1000 K isothermal section when plotted as a ternary diagram. To plot this diagram in Thermo-Calc you define the X- and Y-axes instead of the corner elements.

Define the X- and Y- Plot Axes

The same diagram can therefore be defined with different combinations of the plot axes. In this example, there is Cr in the bottom left corner and Fe in the lower right corner. Then you can define the X-axis by **Fe increasing** from 0 to 100 (these numbers are entered in the **Limits** fields). It is also possible to define the X-axis by *decreasing Cr* from 100 to 0. The main reason for defining a decreasing plot axis in Thermo-Calc is when comparing with experimental diagrams that can be visualized in this way.

To define a decreasing plot axis, on the **Plot Renderer**, click to deselect the **Automatic scaling** checkbox. Then either change the limits as described above by entering 100.0 and 0.0 in the fields, or click the **Swap** button to swap the lower (0.0) and upper (100.0) limits.

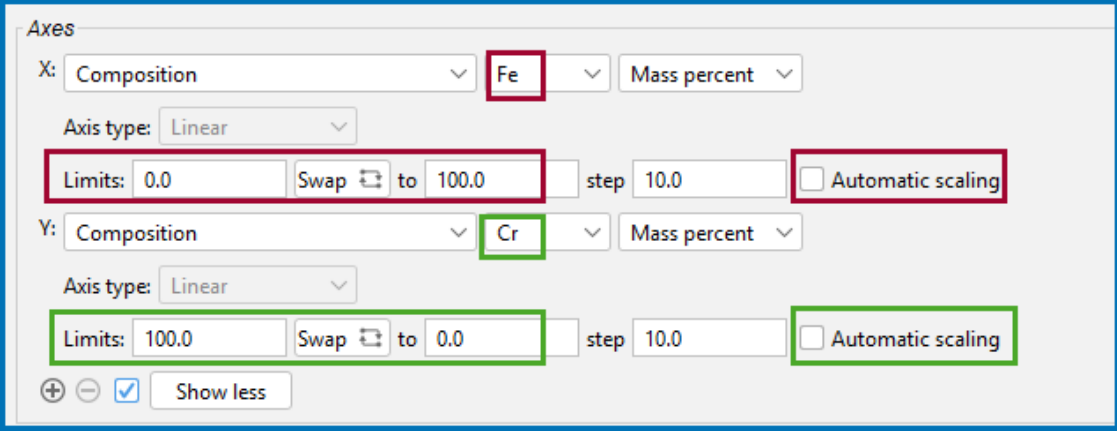

The screenshot shows the 'Axes' configuration panel in Thermo-Calc. It is divided into two sections for the X and Y axes. The X-axis is configured with 'Composition' selected, 'Fe' as the element, and 'Mass percent' as the unit. The axis type is 'Linear'. The limits are set to 0.0 and 100.0, with a 'Swap' button between them. The step is 10.0, and the 'Automatic scaling' checkbox is unchecked. The Y-axis is configured with 'Composition' selected, 'Cr' as the element, and 'Mass percent' as the unit. The axis type is 'Linear'. The limits are set to 100.0 and 0.0, with a 'Swap' button between them. The step is 10.0, and the 'Automatic scaling' checkbox is unchecked. At the bottom of the panel, there are expand/collapse icons and a 'Show less' button.



The **Flexible Mode** plot type is used in this example as it allows you to individually work with the axes.

Visualizations



Many of our Graphical Mode examples have video tutorials, which you can access in a variety of ways. When in Thermo-Calc, from the menu select **Help** → **Video Tutorials**, or from the main My Project window, click **Video Tutorials**. Alternately, you can go to the [website](#) or our [YouTube channel](#).

Open the example project file to review the node setup on the **Project** window and the associated settings on the **Configuration** window for each node. For some types of projects, you can also adjust settings on the **Plot Renderer Configuration** window to preview results before performing the simulation. Click **Perform Tree** to generate plots and tables to see the results on the **Visualizations** window.

Project File Information

- Folder: **Thermo-Calc**
- File name: *T_20_Ternary_Cr-Fe-Ni_Clockwise_Axes.tcu*

In the installed example the Plot Renderer node is renamed to **Counterclockwise x:+Fe y:-Cr**. As above, the settings are completed on the **Configuration** window to plot the **Composition of Fe** on the X-axis and **Cr** decreasing on the Y-axis. Click **Perform** to display the result of [Figure 27](#).

You can continue on the Plot Renderer to plot different combinations of axes variables in order to represent clockwise and counterclockwise plot axes.

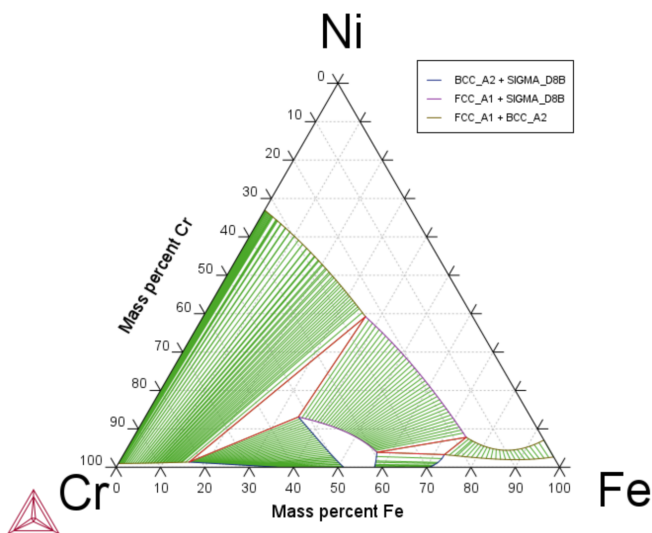

Figure 27: Counterclockwise x:+Fe y:-Cr. Increasing Mass percent Fe (X-axis). Decreasing Mass percent Cr (Y-axis).

Then for the other plot examples, the settings on each **Plot Renderer Configuration** window (for renamed nodes **Clockwise x:-Cr y:+Ni** and **Counterclockwise x:+Fe y:+Ni**) are also changed to show the different combinations of plot axes.

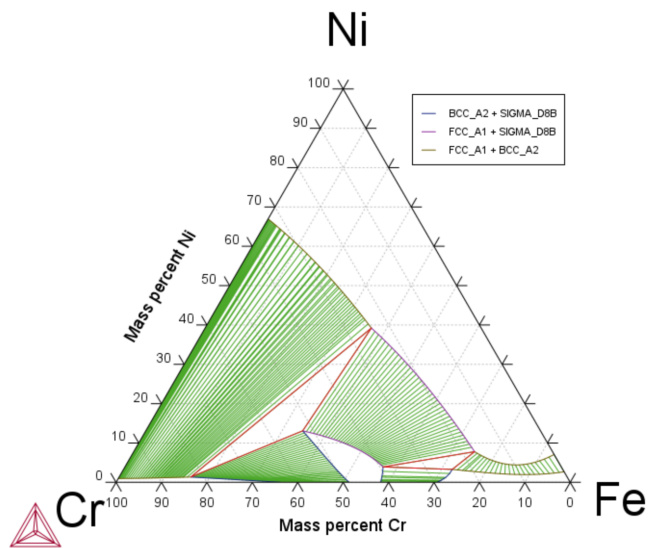

Figure 28: Clockwise x:-Cr y:+Ni: Decreasing Mass percent Cr (X-axis). Increasing Mass percent Ni (Y-axis).

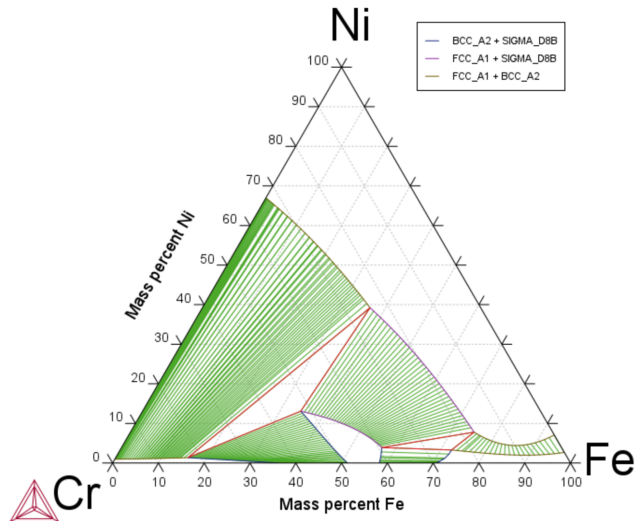

Figure 29: Counterclockwise x:+Fe y:+Ni: Increasing Mass percent Fe (X-axis). Increasing Mass percent Ni (Y-axis).

T_21: Pourbaix Diagrams of Fe with the Aqueous Calculator

In Graphical Mode, you use the **Aqueous Calculation** template in combination with an appropriate database to calculate aqueous corrosion and Pourbaix diagrams.



The free PAQ2 database is used in this example to give all users the opportunity to experiment with these types of calculations. No additional license is required.

The aqueous template adds a **System Definer**, **Aqueous Calculator**, and **Plot Renderer** with default settings specialized for aqueous calculations.

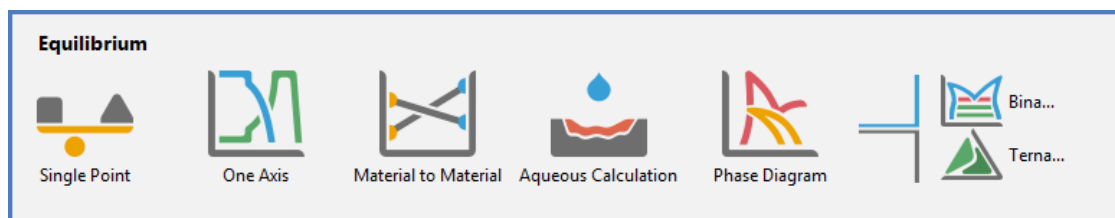

Figure 30: To add the template, click **Aqueous Calculation** from the **My Project** page in the **Equilibrium** group.

This example uses the aqueous template to plot Pourbaix diagrams of Fe under different conditions. The stability lines for H_2 and O_2 gas formation is calculated in a separate **Aqueous Calculator** (which is renamed) and overlaid to the Pourbaix diagrams.



Also see the companion example, "T_22: Aqueous pH of Solutions" on page 56.

In this example the Pourbaix diagram for Fe is calculated under normal conditions and in equilibrium with CO_2 gas. The formation of H_2 and O_2 gas is not considered in the calculations (GAS phase is set to suspended/dormant) and instead the formation lines are calculated separately and overlaid to the plot.

Since GAS is suspended from the Pourbaix calculation and we want to overlay the gas formation lines separately, you need to prevent H_2 and O_2 containing species to form in the AQUEOUS phase. This is handled on the **System Definer** window from the **Phases and Phase Constituent** tab.

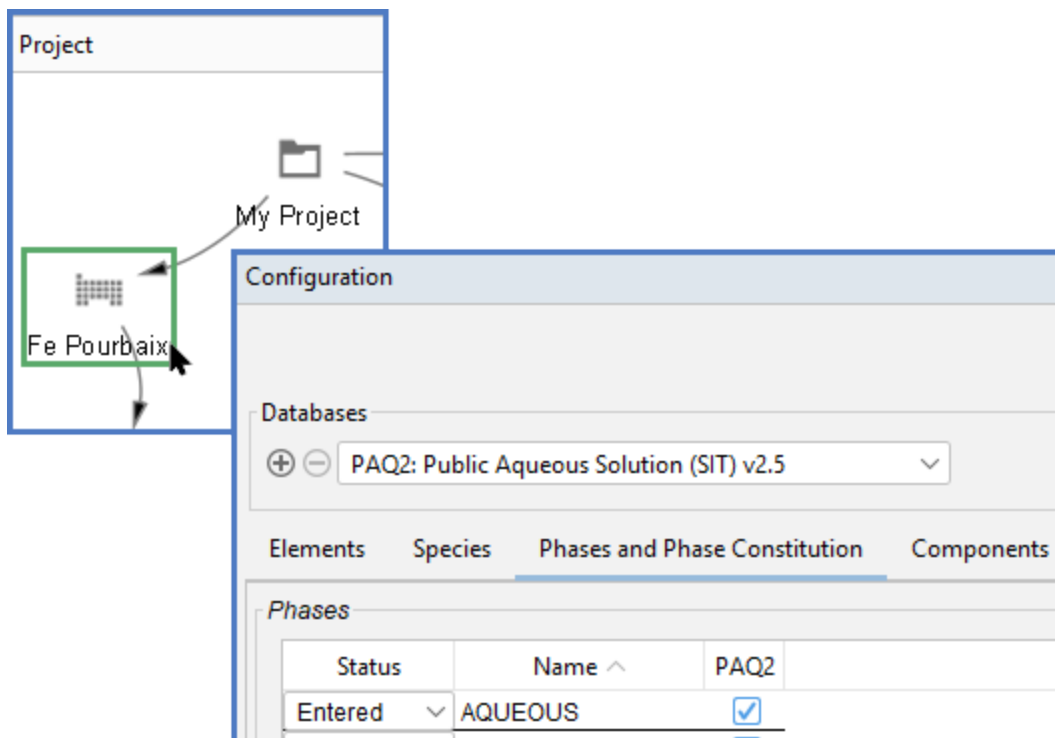

On this tab, at the top under **Phases > Name**, click the AQUEOUS phase. This populates the *Constitution* details for the PAQ2 database at the bottom of the window where you next click **Edit** to add/remove species.

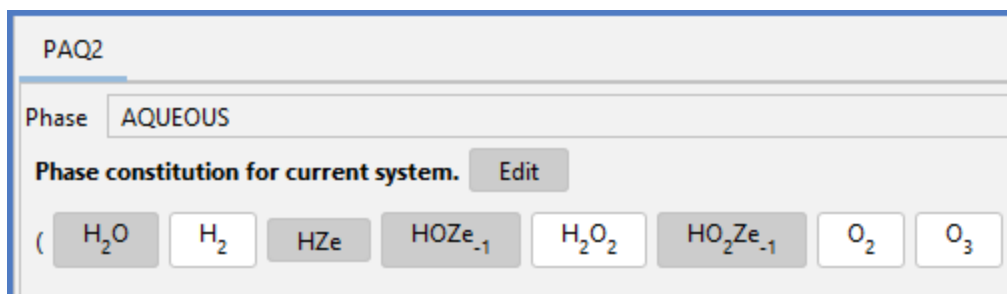

A similar process is done when in equilibrium with CO_2 .



In a Pourbaix calculation it is not always certain that conditions can be fulfilled (eg. some pH/Eh combinations CANNOT reach equilibrium under the constraints set).

Project File Information

- Folder: **Thermo-Calc**
- File name: *T_21_Aqueous_Fe-Pourbaix.tcu*



When the Aqueous Calculator is added to your project using the template, this allows for efficient setup of advanced aqueous calculations. For optimal results, the latest version (TCAQ4) of the TCS Aqueous Solutions Database (TCAQ) is recommended as it is designed specifically for this. Although other versions (TCAQ 3.1 and older) and the free PAQ2 database can be used, there are limitations and additional requirements to conduct more complex simulations.

Visualizations



Many of our Graphical Mode examples have video tutorials, which you can access in a variety of ways. When in Thermo-Calc, from the menu select **Help → Video Tutorials**, or from the main My Project window, click **Video Tutorials**. Alternately, you can go to the [website](#) or our [YouTube channel](#).

Open the example project file to review the node setup on the **Project** window and the associated settings on the **Configuration** window for each node. For some types of projects, you can also adjust settings on the **Plot Renderer Configuration** window to preview results before performing the simulation. Click **Perform Tree** to generate plots and tables to see the results on the **Visualizations** window.

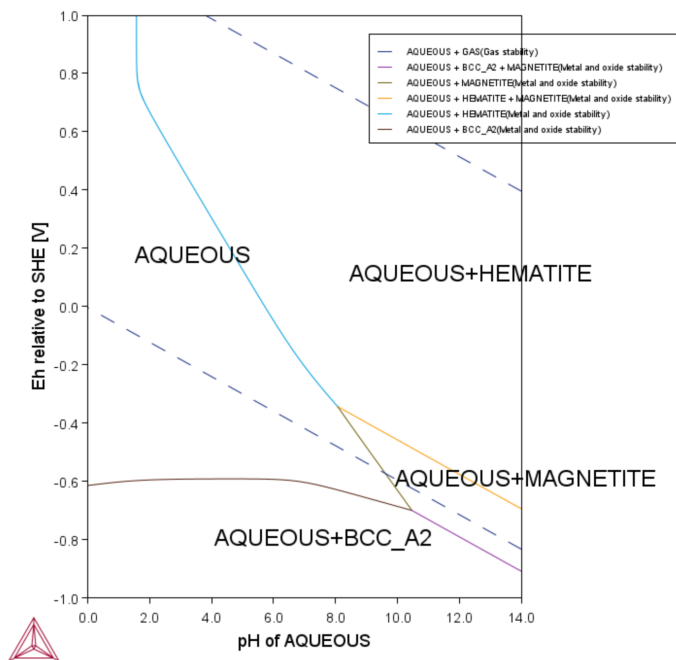

Figure 31: The Fe Pourbaix diagram, which is a plot result sourced from two renamed Aqueous Calculators (the "Metal and oxide stability" and "Gas stability" nodes).

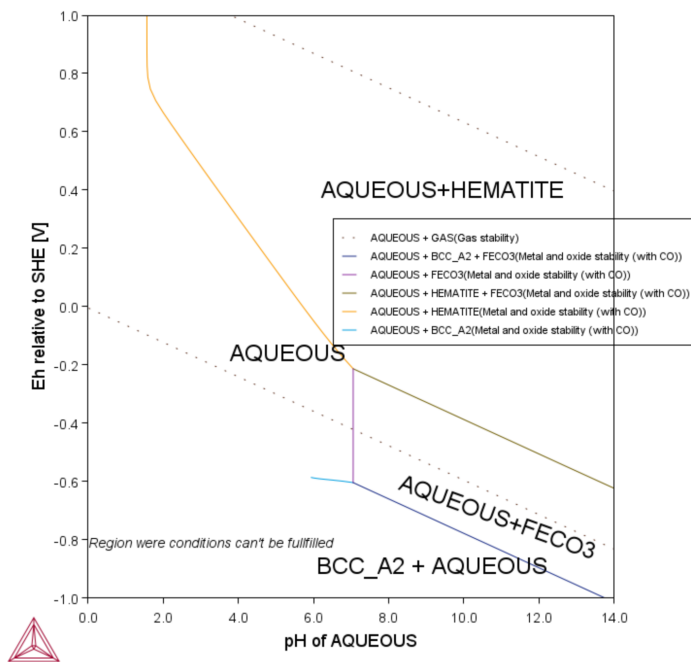

Figure 32: The Fe Pourbaix diagram in equilibrium with CO₂. This is a result plot sourced from two renamed Aqueous Calculators (the "Gas stability" and "Metal and oxide stability (with CO₂)" nodes).

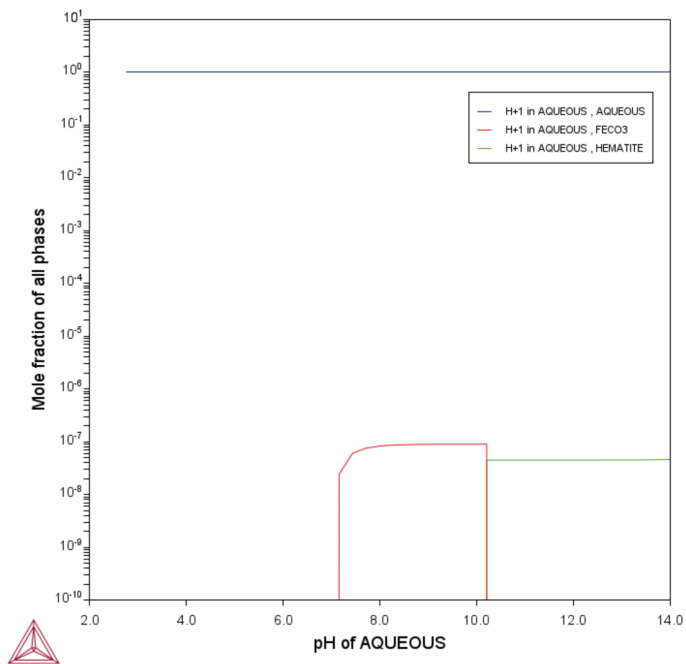

Figure 33: Phases formed at different pH of the aqueous solution. This is a plot result from the Aqueous Calculator renamed to "Step in pH".

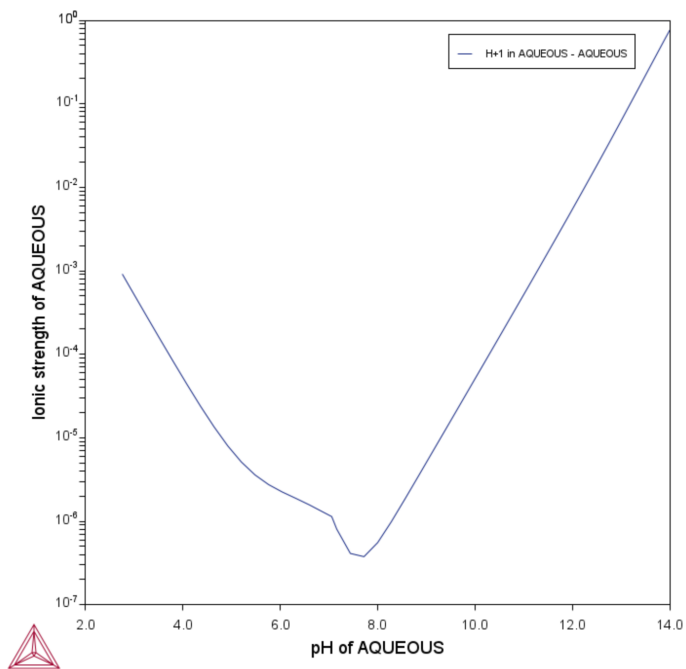

Figure 34: Ionic strength of the aqueous solution. This is a plot result from the Aqueous Calculator renamed to "Step in pH".

More Information



Go to the [Aqueous Solutions Databases](#) page on our website where you can access the latest TCAQ Validation and Calculation Examples Collection and the Technical Information. Also explore further options to work with aqueous solutions and this database using the [Aqueous Calculator](#).

T_22: Aqueous pH of Solutions

In Graphical Mode, you use the **Aqueous Calculator** in combination with an appropriate database to calculate aqueous property diagrams.



The free PAQ2 database is used in this example to give all users the opportunity to experiment with these types of calculations. No additional license is required.

This example has two calculations using the **Aqueous Calculation** template.

The aqueous template adds a **System Definer**, **Aqueous Calculator**, and **Plot Renderer** with default settings specialized for aqueous calculations.

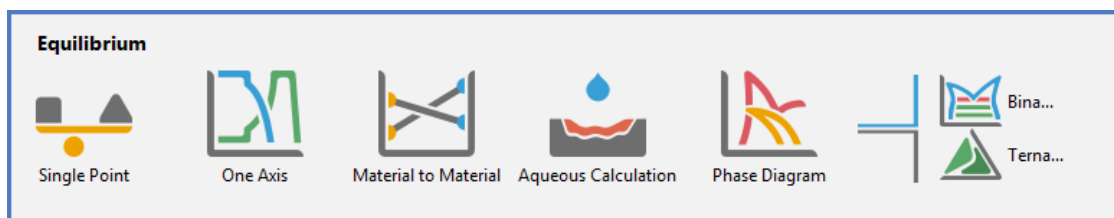

Figure 35: To add the template, click **Aqueous Calculation** from the **My Project** page in the **Equilibrium** group.



Also see the companion example, "T_21: Pourbaix Diagrams of Fe with the Aqueous Calculator" on page 50.

The first calculation shows how to calculate the pH of 1kg H₂O-0.1kg NaCl solution in equilibrium with CO₂ gas. The calculation uses the template defaults set on the **System Definer** (renamed in the example to **H₂O-0.1NaCl in CO₂ equilibrium**) and the **Aqueous Calculator** (renamed to **Step in T**).

On the **Aqueous Calculator**, in the *Condition Definitions* section, you include user-defined conditions to ensure there is 0.1 kg of NaCl in the solution. Setting the amount of **Ze** and **H+1** to **0.0** also ensures there is a neutral solution. See the results when this is run in [Figure 36](#) and [Figure 37](#).

Configuration

Step in T

Conditions Functions Options

Number of missing conditions is 0

Condition Definitions

<input checked="" type="checkbox"/>	<input type="checkbox"/>	<input checked="" type="checkbox"/>	Temperature	Celsius	25.0
<input checked="" type="checkbox"/>	<input type="checkbox"/>	<input checked="" type="checkbox"/>	Pressure	Pascal	100000.0
<input checked="" type="checkbox"/>	<input type="checkbox"/>	<input checked="" type="checkbox"/>	Amount of component	No normalization	Ze Mole 0.0
<input checked="" type="checkbox"/>	<input type="checkbox"/>	<input checked="" type="checkbox"/>	Amount of component	No normalization	H2O Kilogram 1.0
<input checked="" type="checkbox"/>	<input type="checkbox"/>	<input checked="" type="checkbox"/>	Amount of component	No normalization	H+1 Mole 0.0
<input checked="" type="checkbox"/>	<input type="checkbox"/>	<input checked="" type="checkbox"/>	User-defined	N(NA)-N(CL)=0	
<input checked="" type="checkbox"/>	<input type="checkbox"/>	<input checked="" type="checkbox"/>	User-defined	B(NA)+B(CL)=100	
<input checked="" type="checkbox"/>	<input type="checkbox"/>	<input checked="" type="checkbox"/>	Activity referred to a phase	GAS	C1O2 In 1.0

The second calculation shows how to predict pH of a solution with 1 kg H₂O with 1 mole (HCl-HNO₃) mixture.

This calculation shows how you can change the components for the calculation for an easier setup.

On the **System Definer** (renamed to **1kgH2O-1moleHCl-HNO3 mixture**) on the **Components** tab, you change the component N to **NO3-1** and Cl to **CL-1** and then you can construct the HCl-HNO₃ mixture directly in combination with the **H+1** component using user-defined conditions.

Configuration

1kgH2O-1moleHCl-HNO3 mixture

Databases

PAQ2: Public Aqueous Solution (SIT) v2.5 Package: -----

Elements Species Phases and Phase Constitution Components Data Sources Description

Component	Reference phase	Reference temperature	Reference pressure
H2O	<input checked="" type="checkbox"/> SER	Kelvin	Pascal
H+1	<input checked="" type="checkbox"/> SER	Current temperature	Current temperature
Ze	<input type="checkbox"/> SER REF_ELECTRODE	Current temperature	Current temperature
NO3-1	<input checked="" type="checkbox"/> SER	Current temperature	Current temperature
CL-1	<input checked="" type="checkbox"/> SER	Current temperature	Current temperature

Then on the **Aqueous Calculator** (renamed to **1kg-H2O-1moleHCl-HNO3 mixture (Calc)**), with a **One Axis** step in CL-1, you can make predictions of pH for the 1 kg H₂O with 1 mole HCl-HNO₃ mixture and see how it changes with amount of HCl. See [Figure 38](#) for the result.

Calculation Type					
<input type="radio"/> Single equilibrium	<input checked="" type="radio"/> One Axis	<input type="radio"/> Grid	<input type="radio"/> Phase diagram		
Axis Definitions					
Quantity	Min	Max	Step division	Type	Step Method
Amount of CL-1	0.0	1.0	50.0	Linear - min no. of steps	Normal

Project File Information

- Folder: **Thermo-Calc**
- File name: *T_22_Aqueous_pH_of_Solutions.tcu*



When the Aqueous Calculator is added to your project using the template, this allows for efficient setup of advanced aqueous calculations. For optimal results, the latest version (TCAQ4) of the TCS Aqueous Solutions Database (TCAQ) is recommended as it is designed specifically for this. Although other versions (TCAQ 3.1 and older) and the free PAQ2 database can be used, there are limitations and additional requirements to conduct more complex simulations.

Visualizations



Many of our Graphical Mode examples have video tutorials, which you can access in a variety of ways. When in Thermo-Calc, from the menu select **Help** → **Video Tutorials**, or from the main My Project window, click **Video Tutorials**. Alternately, you can go to the [website](#) or our [YouTube channel](#).

Open the example project file to review the node setup on the **Project** window and the associated settings on the **Configuration** window for each node. For some types of projects, you can also adjust settings on the **Plot Renderer Configuration** window to preview results before performing the simulation. Click **Perform Tree** to generate plots and tables to see the results on the **Visualizations** window.

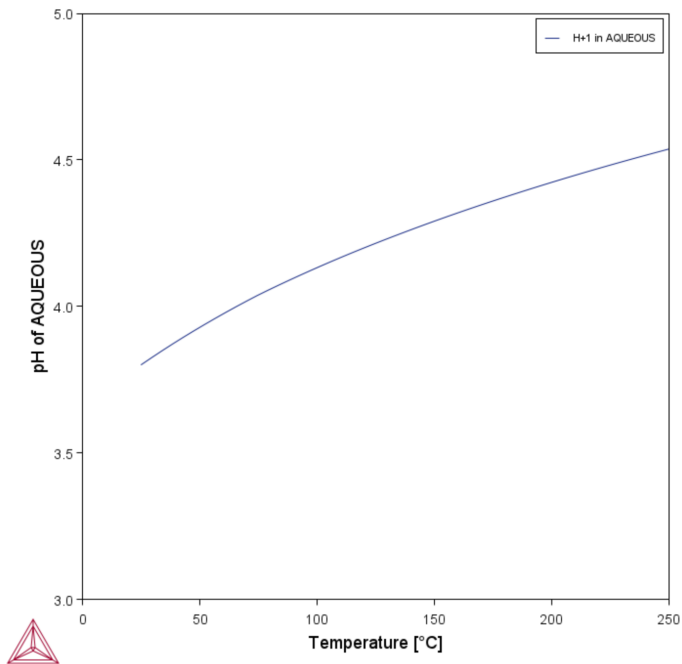

Figure 36: pH of 1kg H₂O-0.1kg NaCl in equilibrium with CO₂ gas in function of temperature.

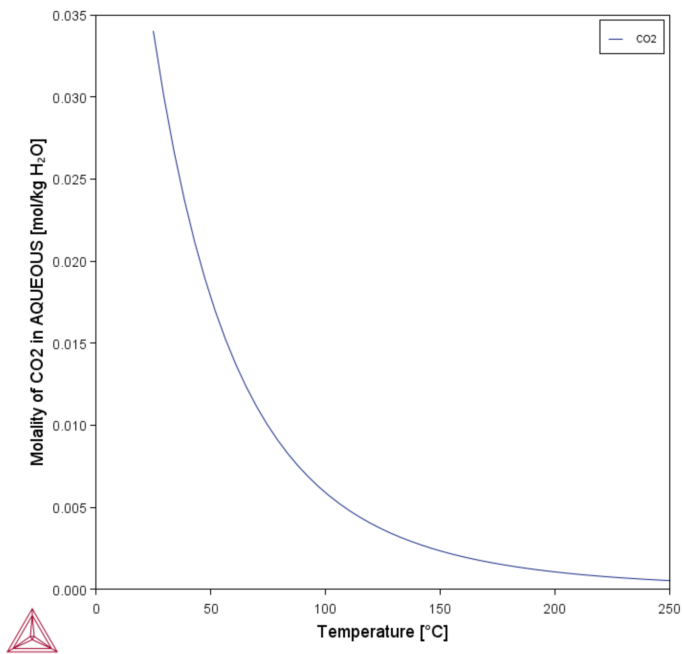

Figure 37: Molality of CO₂ for a aqueous solution 1kg H₂O-0.1kg NaCl in equilibrium with CO₂ gas.

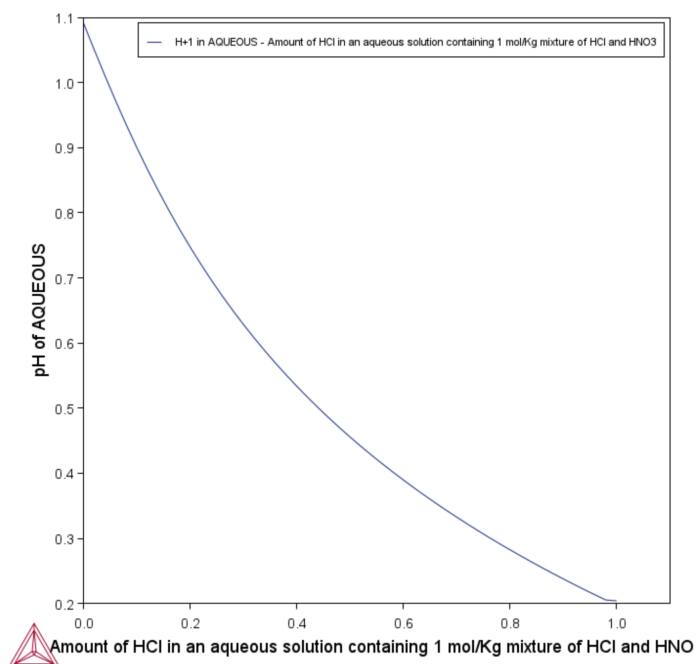

Figure 38: pH for a aqueous solution of 1kg-H₂O-1mole HCl-HNO₃ mixture.

More Information



Go to the [Aqueous Solutions Databases](#) page on our website where you can access the latest TCAQ Validation and Calculation Examples Collection and the Technical Information. Also explore further options to work with aqueous solutions and this database using the [Aqueous Calculator](#).

Thermo-Calc General Property Models Examples Collection

The **General Models** are available to all users.



To run calculations with the Add-on Property Model Libraries all require a valid maintenance license plus a license for the specific database version: **Nickel Models** (TCNI11 and newer and MOBNI5 and newer); **Noble Metal Alloys Models** (TCNOBL3 and newer); **Steel Models** (TCFE9 and newer + MOBFE4 and newer); **Titanium Models** (TCTI6 and newer).

These examples use the **Property Model Calculator**, an activity available with Thermo-Calc.

In this section:

PM_G_01: Phase Transition	63
PM_G_02: Coarsening and Interfacial Energy	66
PM_G_03: Driving Force and Interfacial Energy	70
PM_G_04: Yield Strength	72
PM_G_05: Yield Strength NiAlCr	76
PM_G_06: Yield Strength HEA	78
PM_G_07: Hot Crack Susceptibility	80
PM_G_08: Spinodal	82
PM_G_09: T-Zero Temperature	84
PM_G_10: Freeze-in Thermal Conductivity	86
PM_G_11: Freeze-in Electrical Resistivity	88
PM_G_12: Solidus and Liquidus Batch Calculation	90
PM_G_13: Ti Alloy Design for Additive Manufacturing	92
PM_G_14: Ti-Fe T-Zero Martensite	94
PM_G_15: Columnar to Equiaxed Transition (CET) of a NiAlCr Alloy	96

PM_G_16: Columnar to Equiaxed Transition of a CMSX-4 Alloy	99
PM_G_17: Columnar to Equiaxed Transition of an IN718 Alloy	103
PM_G_18: Equilibrium and Annealing Heat Treatment for ASTM A29	106
PM_G_19: Thermal Conductivity for an AM Cu-Alloy	109
PM_G_20: Scheil for an Al-1Si-1Mn-0.7Mg-0.6Fe-0.1Cu Alloy	111

PM_G_01: Phase Transition

The example uses the **Property Model Calculator** and a **Phase Transition** Property Model to predict the transition temperature to the unwanted brittle sigma phase. The example shows how the temperature is influenced by changes to a steel alloy's composition using the **Uncertainty Calculation Type** and then you can choose to use either a **Histogram** (frequency diagram) or **Probability** plot after choosing the **Statistical Plot type** on the **Plot Renderer**.

Project File Information

- Folder: **Property Models** → **General**
- File name: *PM_G_01_Phase_Transition.tcu*

Visualizations



This example is included as a Property Model tutorial on our [website](#) and as part of the Property Model Calculator playlist on our [YouTube channel](#).

Open the example project file to review the node setup on the **Project** window and the associated settings on the **Configuration** window for each node. For some types of projects, you can also adjust settings on the **Plot Renderer Configuration** window to preview results before performing the simulation. Click **Perform Tree** to generate plots and tables to see the results on the **Visualizations** window.

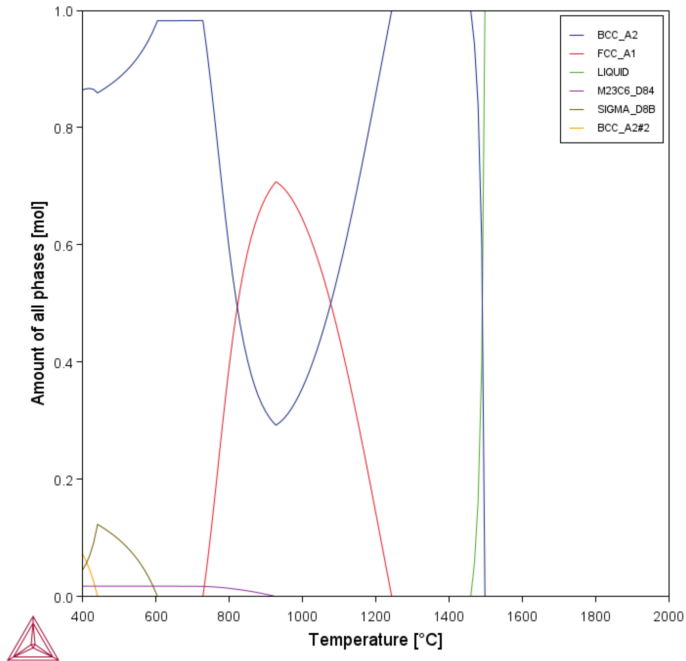

Figure 39: A property diagram as a result of using the Equilibrium Calculator with a One Axis calculation to determine a good starting temperature of the SIGMA phase.

Once you set up the Property Model Calculator, but before running a **Grid** calculation, it is recommended you run a **Single** calculation to make sure the calculation is valid.

- If the subprocess worked, it displays in the **Event Log**. The **Event Log** also has the result `Relaxed condition`, referring to the variable, which in this case is temperature.
- If the calculation did not work, `NaN` (not a number) displays instead. Check your configuration set up and run the calculation again before moving on to the more complicated calculation.

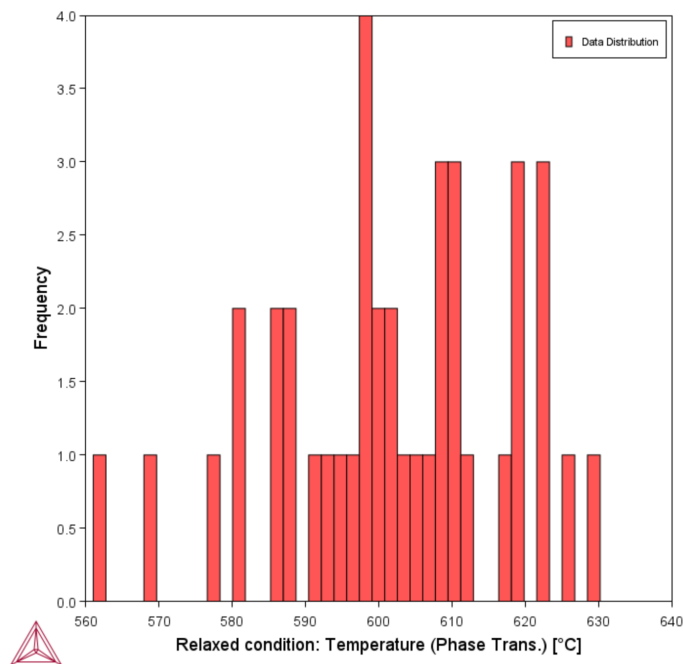

Figure 40: Using the Property Model Calculator with the Phase Transition Model to plot a histogram showing how the transition temperature of sigma varies when you vary the composition. The plot changes each time you run the calculation because it is taking a random sampling from the composition range set.



The X-axis is labeled the **Relaxed Condition: Temperature (Phase Trans.)**, which you can see on the **Plot Renderer 1 Configuration** window. The Y-axis shows the **Frequency**, which is the number of samples out of 40 where the composition transitions at each temperature. You can see that the transitions occur more frequently near the 600 °C starting point and less frequently at the edges.



Since only one variable can serve as a **Relaxed condition** per calculation, the quantity that is not relaxed has a NaN result in its corresponding result quantity. The **Evaluation temperature** result quantity inherits the unit set in the conditions while the **Composition** result quantity inherits the normalization (mole or mass) but always returns a fraction.

PM_G_02: Coarsening and Interfacial Energy

The example uses the **Property Model Calculator** and both thermodynamic (FEDEMO) and kinetic (MFEDEMO) demonstration steel databases. Using a **Grid Calculation Type** it produces these plot types: a **Heat map**, a **Contour plot** and an overlaid plot combining a cross plot with a contour plot (where both the interfacial energy and coarsening rate is shown). It also creates a diagram to show the phase fractions vs time and a **3D Plot type** comparing the coarsening rate coefficient.

Project File Information

- Folder: **Property Models** → **General**
- File name: *PM_G_02_Coarsening_and_Interfacial_energy.tcu*

Visualizations



This example is included as a Property Model tutorial on our [website](#) and as part of the Property Model Calculator playlist on our [YouTube channel](#).

Open the example project file to review the node setup on the **Project** window and the associated settings on the **Configuration** window for each node. For some types of projects, you can also adjust settings on the **Plot Renderer Configuration** window to preview results before performing the simulation. Click **Perform Tree** to generate plots and tables to see the results on the **Visualizations** window.

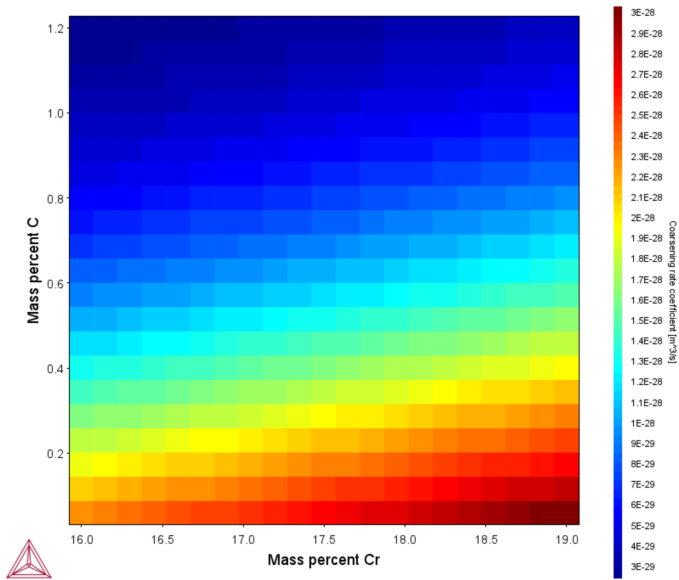

Figure 41: Uses a Property Model Calculator with a Grid Calculation type to plot the coarsening rate coefficient as a Heat map.

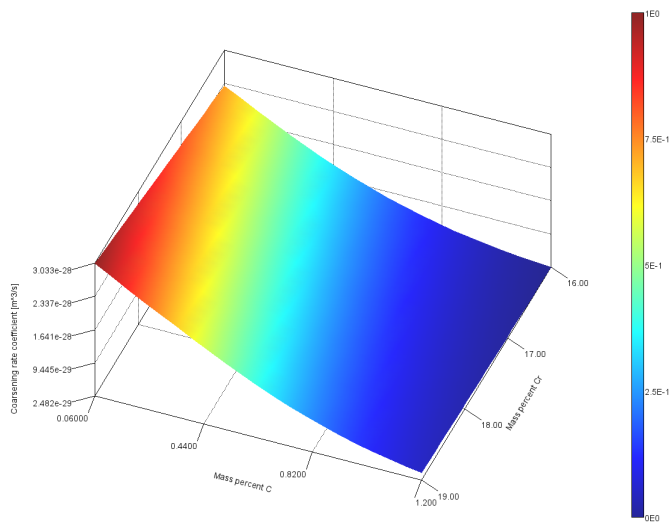

Figure 42: Uses a Property Model Calculator with a Grid Calculation type to plot the coarsening rate coefficient as a 3D plot.

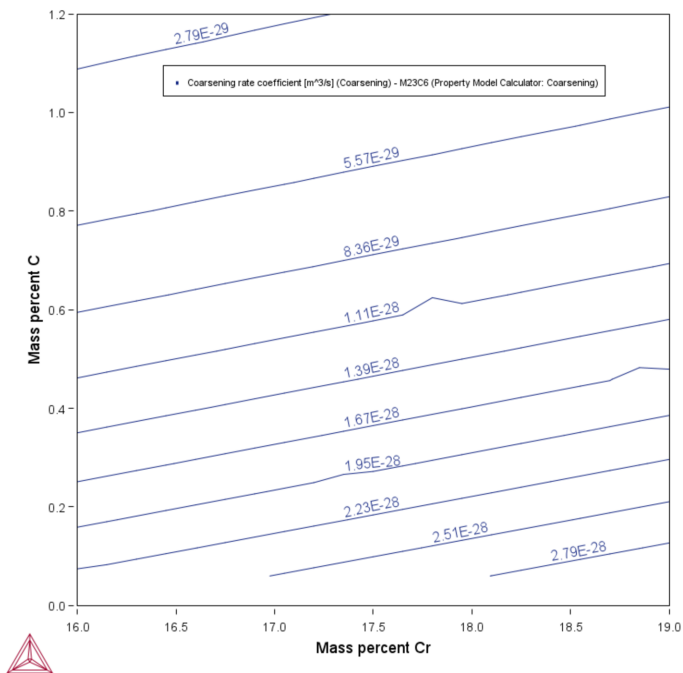

Figure 43: Uses a Property Model Calculator with a Grid Calculation type to plot the coarsening rate coefficient as a Contour plot.

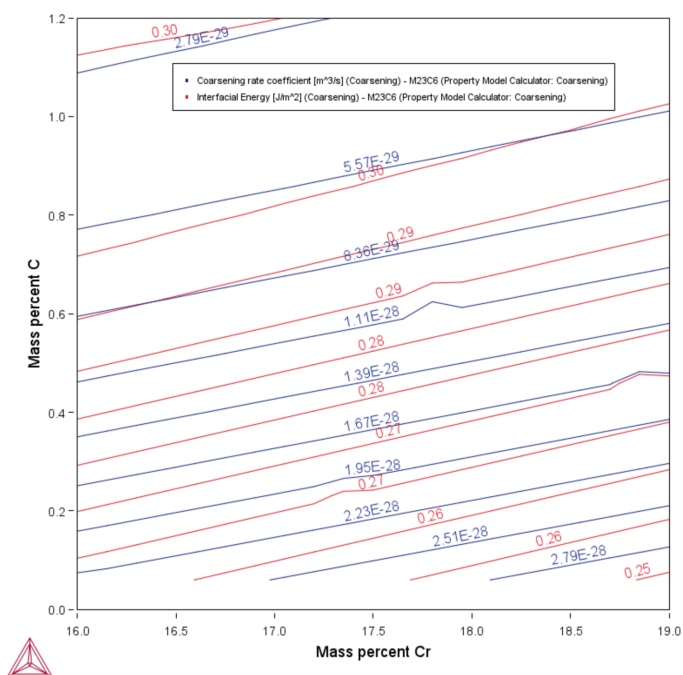

Figure 44: Comparing the coarsening rate coefficient and interfacial energy in overlaid plots.

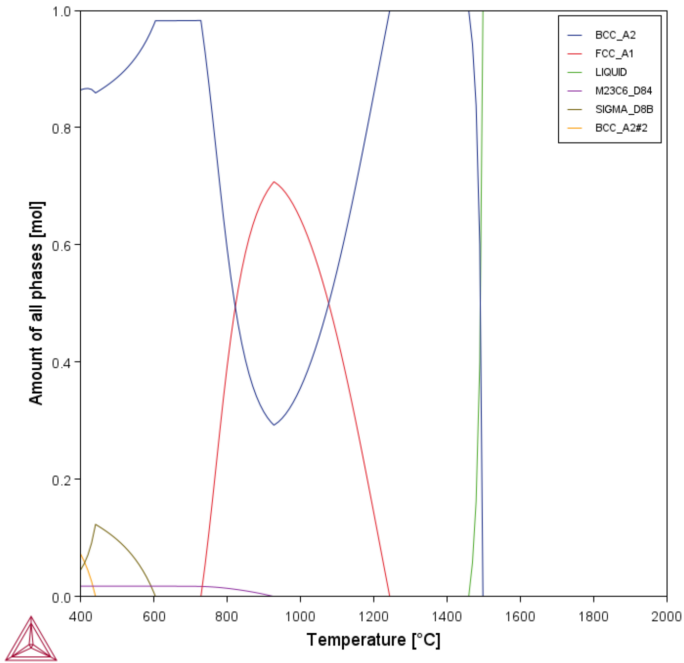

Figure 45: A One Axis Equilibrium calculation showing the phase fractions vs T (with a Flexible Mode plot type).

PM_G_03: Driving Force and Interfacial Energy

The example uses the **Property Model Calculator** and a thermodynamic demonstration steel database (FEDEMO). Using a **Grid Calculation** type it produces a **Contour** plot comparing the driving force and interfacial energy.

Project File Information

- Folder: **Property Models** → **General**
- File name: *PM_G_03_Driving_force_and_Interfacial_energy.tcu*

Visualizations



This example is included as a Property Model tutorial on our [website](#) and as part of the Property Model Calculator playlist on our [YouTube channel](#).

Open the example project file to review the node setup on the **Project** window and the associated settings on the **Configuration** window for each node. For some types of projects, you can also adjust settings on the **Plot Renderer Configuration** window to preview results before performing the simulation. Click **Perform Tree** to generate plots and tables to see the results on the **Visualizations** window.

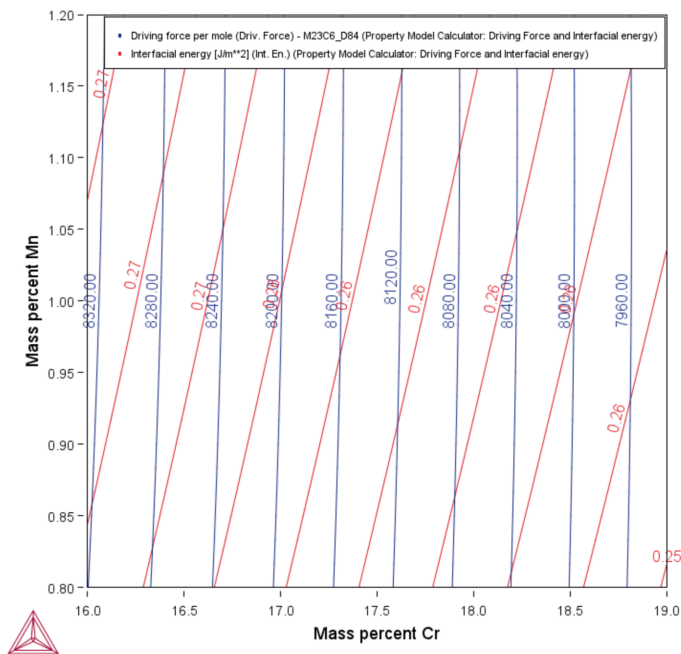

Figure 46: An overlaid Contour plot comparing the driving force and interfacial energy.

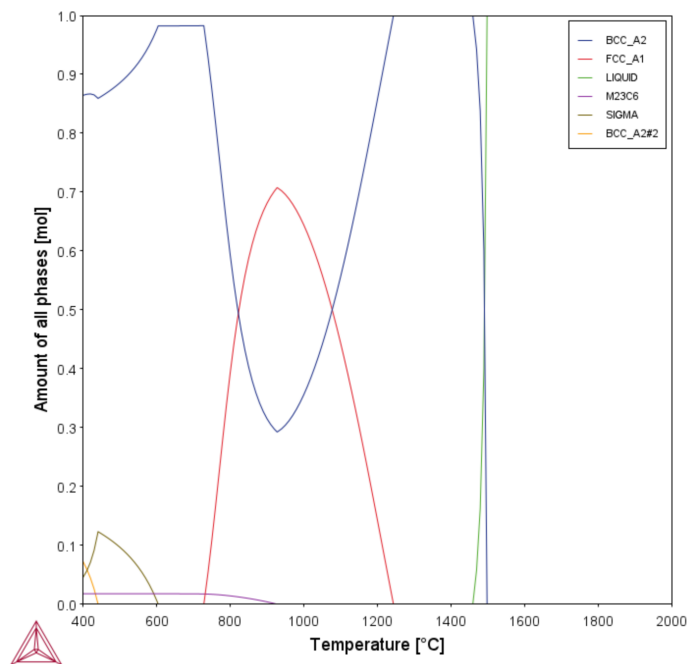

Figure 47: A One Axis Equilibrium calculation showing the Phase fractions vs T.

PM_G_04: Yield Strength

The example uses the **Property Model Calculator** and the **Yield strength** Property Model with a thermodynamic demonstration aluminum database (ALDEMO).

Using default options for the precipitation strengthening models, this example compares the **Simplified model (general)**, **Seidman model (Al-base)** and **Deschamps model (Al-base)** yield strength versus precipitate radius to experimental data for an Al-0.3wt%Sc alloy homogenized at 648 °C for 24 hours and subsequently aged at 350 °C.

The Seidman model [2002Sei] considers a combination of a shearing mechanism and Orowan dislocation bypass mechanism. For the shearing mechanism, the increase in yield strength results from the contributions of ordering strengthening, coherency strengthening, and modulus mismatch strengthening.

When **Seidman model (Al-base)** is selected as the *Precipitation strengthening model*, the setting for α is a constant related to the coherency strengthening of precipitates, which usually varies from 2 to 3. In this example, the default α is 2.6 [1985Ard]. The m setting is the parameter that relates to the modulus mismatch strengthening and the default is set as 0.85 [1985Ard]. This model is applied in the study of precipitation hardening in dilute Al(Sc) alloys containing coherent Al₃Sc precipitates. The model parameters described above can be adjusted to work for hardenable aluminum alloy calculations from the 2000 (Al–Cu and Al–Cu–Mg), 6000 (Al–Mg–Si), and 7000 (Al–Zn–Mg) series.

As a comparison, the **Simplified model** [2008Zan] only considers the general mechanisms of cutting and looping (Orowan mechanism) without regard to any detailed dislocation mechanisms.

When **Simplified model (general)** is selected as the *Precipitation strengthening model*, the default *Critical radius* (the critical size r_c) is optimized against experimental results for dilute Al-Sc. If the precipitates are smaller than a critical size (approximately 5–10 nm) the dislocations cut the precipitates. The strength of the obstacle is then proportional to the square root of the average radius. If the particles are larger than the critical size, r_c , it is less costly for the dislocations to bow round the particles and the strengthening contribution is inversely proportional to r . Since the **Simplified model (general)** only depends on generic material constants (k_p and r_c) it may be applied to any precipitation strengthened material.

The **Deschamps model (Al-base)** model [1998Des], is for precipitation strengthening, mainly intended for use with Al-base alloys. The Deschamps model includes use of Friedel or Kock's statistics for particle size distribution. Default parameters are used to match a dilute Al-Sc alloy with Al₃Sc precipitates. As is done for the other precipitation strengthening models, a critical radius, describing the transition from cutting to looping, must be specified when you are setting up the configuration.

Project File Information

- Folder: **Property Models** → **General**
- File name: *PM_G_04_Yield_Strength.tcu*

Visualizations



Many of our Graphical Mode examples have video tutorials, which you can access in a variety of ways. When in Thermo-Calc, from the menu select **Help** → **Video Tutorials**, or from the main My Project window, click **Video Tutorials**. Alternately, you can go to the [website](#) or our [YouTube channel](#).

Open the example project file to review the node setup on the **Project** window and the associated settings on the **Configuration** window for each node. For some types of projects, you can also adjust settings on the **Plot Renderer Configuration** window to preview results before performing the simulation. Click **Perform Tree** to generate plots and tables to see the results on the **Visualizations** window.

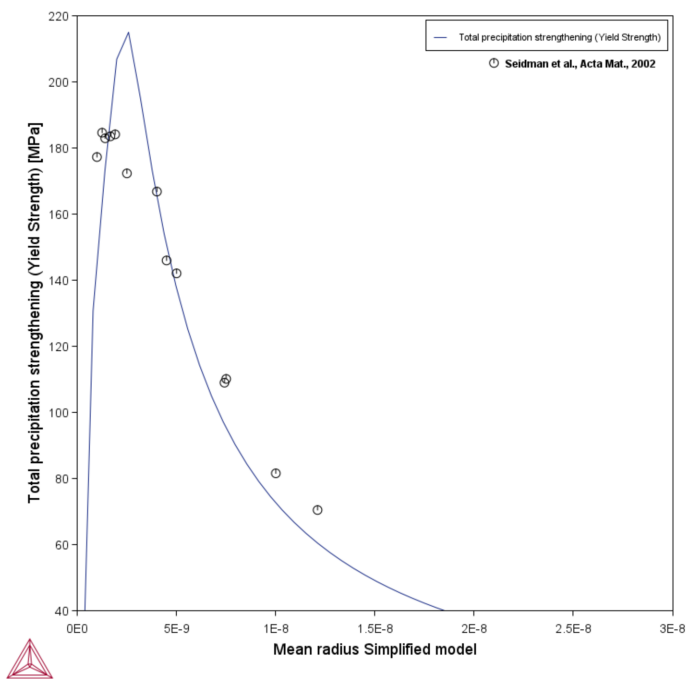

Figure 48: Strength vs Radius - Simplified compared to experimental data from [2002Sei].

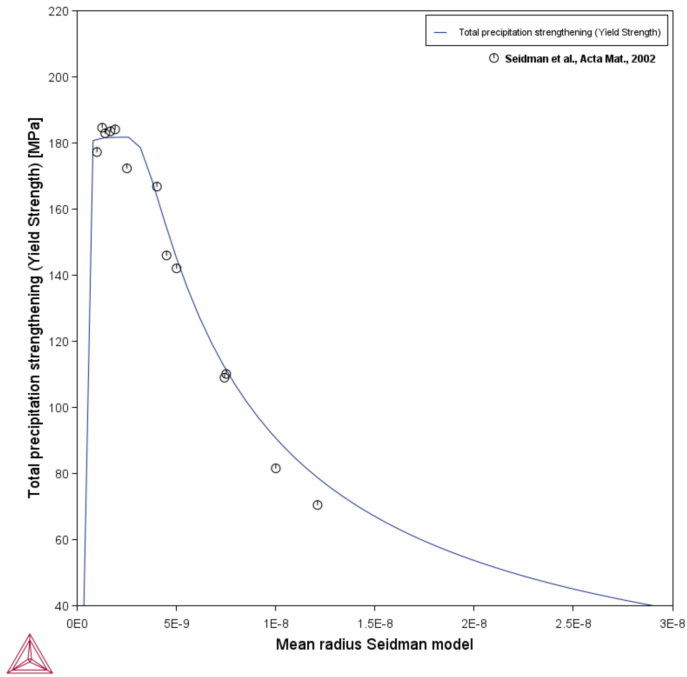

Figure 49: Strength vs Radius - Seidman compared to experimental data from [2002Sei].

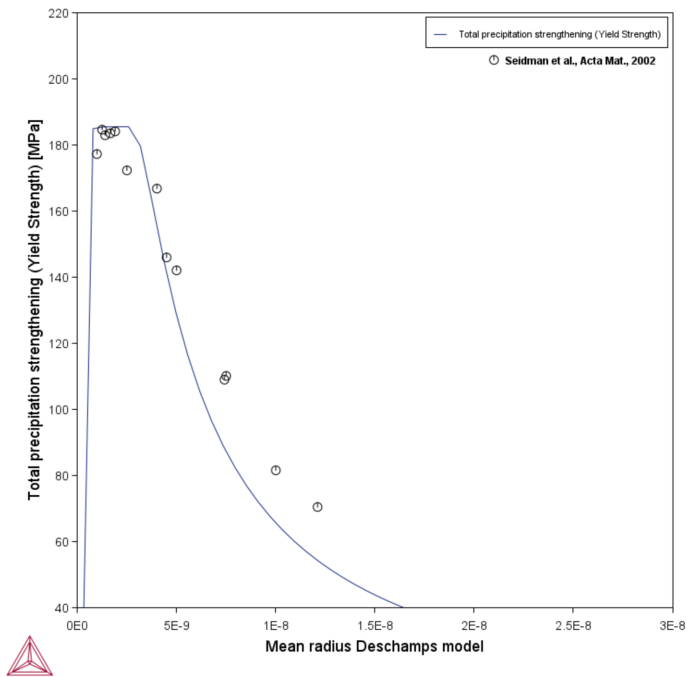

Figure 50: Strength vs Radius - Deschamps compared to experimental data from [2002Sei].

References

[1985Ard] A. J. Ardell, Precipitation hardening. Metall. Trans. A. 16, 2131–2165 (1985).

- [1998Des] A. Deschamps, Y. Brechet, Influence of predeformation and ageing of an Al–Zn–Mg alloy—II. Modeling of precipitation kinetics and yield stress. *Acta Mater.* 47, 293–305 (1998).
- [2002Sei] D. N. Seidman, E. A. Marquis, D. C. Dunand, Precipitation strengthening at ambient and elevated temperatures of heat-treatable Al(Sc) alloys. *Acta Mater.* 50, 4021–4035 (2002).
- [2008Zan] J. Zander, R. Sandström, One parameter model for strength properties of hardenable aluminium alloys. *Mater. Des.* 29, 1540–1548 (2008).
-

PM_G_05: Yield Strength NiAlCr

The example uses the **Property Model Calculator** and the **Yield strength** Property Model with a thermodynamic demonstration nickel database (NIDEMO).

The Reppich model is developed for calculation of precipitation strengthening in Ni-based super alloys consisting mainly of gamma prime (γ') precipitates in a gamma matrix. The example shows a calculation of the precipitation strengthening vs precipitate radius in a Ni-10at%Al-10at%Cr alloy.

This example uses the Reppich model [1982Rep] which is developed and rests on existing hardening models estimating the increase of the yield stress due to pairwise particle cutting and antiphase domain boundary (APB) formation. The effect of the anisotropy on the dislocation line tension of two-phase material and on the Orowan stress is taken into account. Compared to conventional APB hardening theories, this model can be applied to large volume fraction of precipitates in the anisotropic systems.

For the settings input of the **Reppich model (Ni-base)**:

- A is a numerical factor depending on the morphology of the precipitates. For spherical particles, A equals to 0.72.
- w represents the elastic repulsion between the strongly paired dislocations, which can be determined by the experimental data [1979Hüt].

In this example, A and w are set by default to 0.7639 and 0.2919, respectively. The C factor default of 0 is not changed.

Project File Information

- Folder: **Property Models** → **General**
- File name: *PM_G_05_Yield_Strength_NiAlCr.tcu*

Visualizations



Many of our Graphical Mode examples have video tutorials, which you can access in a variety of ways. When in Thermo-Calc, from the menu select **Help** → **Video Tutorials**, or from the main My Project window, click **Video Tutorials**. Alternately, you can go to the [website](#) or our [YouTube channel](#).

Open the example project file to review the node setup on the **Project** window and the associated settings on the **Configuration** window for each node. For some types of projects, you can also adjust settings on the **Plot Renderer Configuration** window to preview results before performing the simulation. Click **Perform Tree** to generate plots and tables to see the results on the **Visualizations** window.

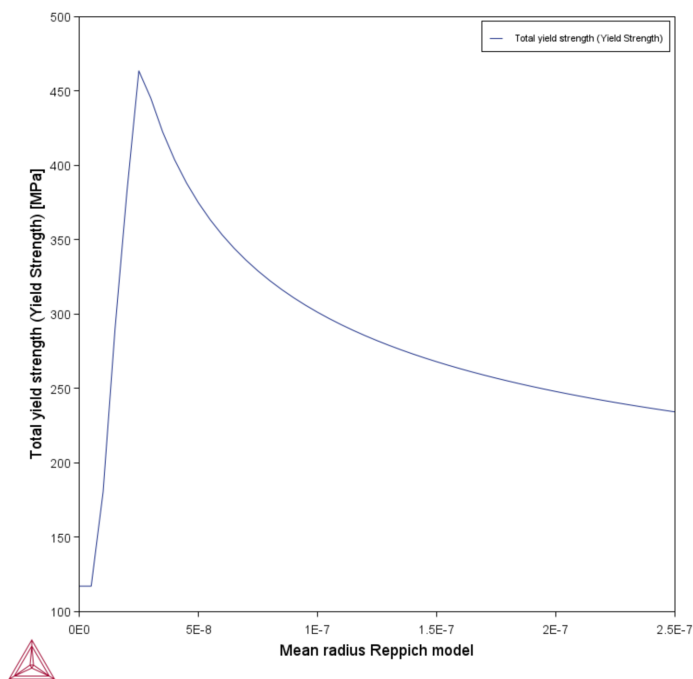

Figure 51: Reppich model plotted with results and experimental data for PE16, all data is normalized with the square root of the volume fraction of precipitate.

References

- [1979Hüt] W. Hüther, B. Reppich, Order hardening of MgO by large precipitated volume fractions of spinel particles. Mater. Sci. Eng. 39, 247–259 (1979).
- [1982Rep] B. Reppich, Some new aspects concerning particle hardening mechanisms in γ' precipitating Ni-base alloys—I. Theoretical concept. Acta Metall. 30, 87–94 (1982).

PM_G_06: Yield Strength HEA

The example uses the **Property Model Calculator** and the **Yield strength** Property Model with the thermodynamic TCS High Entropy Alloys Database (TCHEA). It is an example of solid solution strengthening, which is the contribution to total strength due to the elastic strains in the crystal lattice caused by alloying elements of a lattice parameter differing from the main constituent. The example shows the solid solution strengthening at 300 K and 411 K over the full solubility range for the Mo-Ta system as compared to experimental data [1972Ste].

Project File and License Information

- Folder: **Property Models** → **General**
- File name: *PM_G_06_Yield_Strength_HEA.tcu*



This example requires the use of the TCS High Entropy Alloys Database (TCHEA). A license is required to run the example.



This example is configured to run with BCC_A2 selected and BCC_B2/BCC_B2#2 deselected in the **System Definer** → **Phases and Phase Constitution** tab, when using version 8 (TCHEA8) or higher. If the database is changed to an earlier version, this selection is reset by the software and you need to either manually re-apply these settings on the System Definer or reopen the example.

Visualizations



Many of our Graphical Mode examples have video tutorials, which you can access in a variety of ways. When in Thermo-Calc, from the menu select **Help** → **Video Tutorials**, or from the main My Project window, click **Video Tutorials**. Alternately, you can go to the [website](#) or our [YouTube channel](#).

Open the example project file to review the node setup on the **Project** window and the associated settings on the **Configuration** window for each node. For some types of projects, you can also adjust settings on the **Plot Renderer Configuration** window to preview results before performing the simulation. Click **Perform Tree** to generate plots and tables to see the results on the **Visualizations** window.

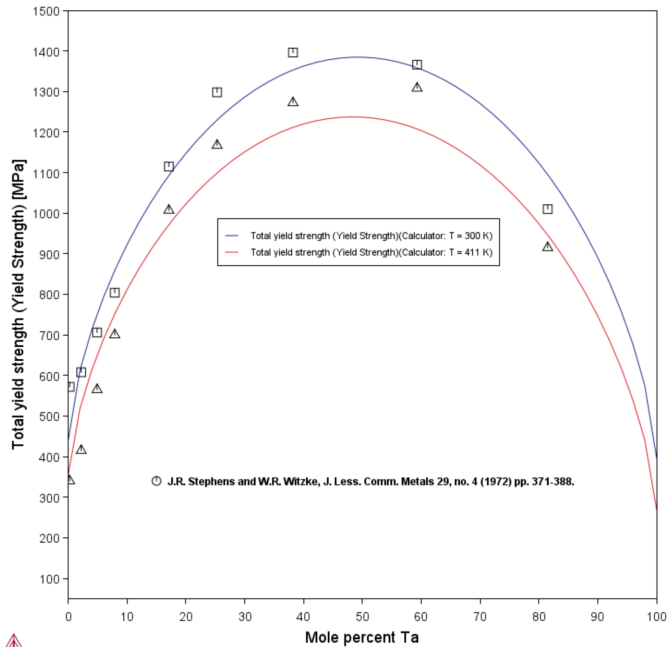

Figure 52: The solid solution strengthening over the full solubility range for the Mo-Ta system as compared to experimental data [1972Ste].

Reference

[1972Ste] J. R. Stephens, W. R. Witzke, Alloy hardening and softening in binary molybdenum alloys as related to electron concentration. J. Less Common Met. 29, 371–388 (1972).

PM_G_07: Hot Crack Susceptibility

The example uses the **Property Model Calculator** and the **Crack Susceptibility Coefficient Model** to calculate the hot tearing tendency during solidification for an Al-Si alloy. The **ALDEMO: Aluminum Demo Database** is used and this example is available to all users.

The **Crack Susceptibility Coefficient** Property Model, available as a General model with the Property Model Calculator, calculates the crack susceptibility coefficient, which describes the risk or tendency of a material to experience cracking or *hot tearing* during solidification. Cracking/hot tearing is one of the most common and serious defects encountered during the casting of, for example, aluminum alloys. In general, it is defined by the formation of a macroscopic fissure in a casting because of stress and the associated strain, generated during cooling, at a temperature above the non-equilibrium solidus. Crack susceptibility is also referred to as solidification cracking, hot cracking, hot shortness, supersolidus cracking, and shrinkage brittleness. The Crack Susceptibility Coefficient (CSC) is calculated using Scheil results with three different model options: *Clyne and Davies*, *Kou*, and *Easton*.

The Model is based on the publication by Yan and Lin [2006Yan] and uses experimental data [1955Pum; 1976Feu; 2004Bar] from this paper.

The experimental hot cracking susceptibility of an alloy is defined as the ratio between the cracking length for that alloy and the maximum cracking length in the alloy system studied. Considering the uncertainties and difficulties in hot tearing measurements, the calculated hot tearing tendencies are in excellent agreement with the experimental data. The typical L-shaped curve is well reproduced in the current prediction. It rapidly increases at a low solute content and has a maximum at a composition of around 0.5 wt pct Si.

Project File Information

- Folder: **Property Models** → **General**
- File name: *PM_G_07_Hot_Crack_Susceptibility.tcu*

Visualizations



This example is included as a Property Model tutorial on our [website](#) and as part of the Property Model Calculator playlist on our [YouTube channel](#).

Open the example project file to review the node setup on the **Project** window and the associated settings on the **Configuration** window for each node. For some types of projects, you can also adjust settings on the **Plot Renderer Configuration** window to preview results before performing the simulation. Click **Perform Tree** to generate plots and tables to see the results on the **Visualizations** window.

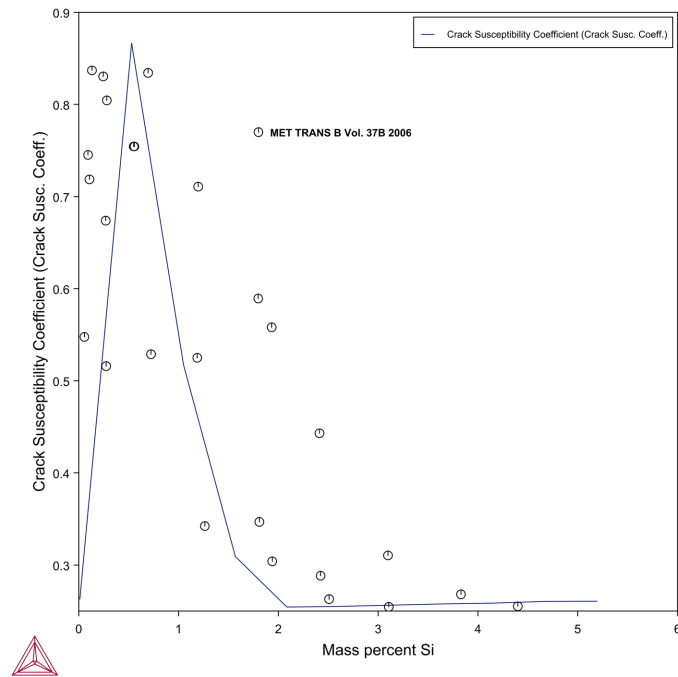

Figure 53: The plot compares the predicted cracking susceptibility/composition curve for the Al-Si system with the experimental hot tearing tendencies [1955Pum; 1976Feu; 2004Bar].

References

- [1955Pum] W.I. Pumphrey: "The Aluminum Development Association Report No. 27," Aluminum Development Association, London, 1955.
- [1976Feu] U. Feurer, Mathematical Model by the Hot Cracking Tendency of Binary Aluminum Alloys. *Giessereiforschung*. 28, 75–80 (1976).
- [2004Bar] S. R. Barnett, J. A. Taylor, and D. H. St. John: Solidification of Aluminum Alloys, M.G. Chu, D.A. Granger, and Q. Han, eds., TMS, Warrendale, PA, 2004, pp. 201-09.
- [2006Yan] X. Yan and J. C. Lin, "Prediction of hot tearing tendency for multicomponent aluminum alloys," *Metall. Mater. Trans. B*, vol. 37, no. 6, pp. 913–918, Dec. 2006.

PM_G_08: Spinodal

The example uses the **Property Model Calculator** and the **Spinodal** Property Model to calculate the so-called spinodal curve for the BCC_A2 miscibility gap in the system Fe-Cr. The **FEDEMO: Iron Demo Database** is used and this example is available to all users.

Two Property Model Calculators are used in this example. The spinodal curve (a **One Axis** calculation), is overlaid on top of a the Fe-Cr **Phase diagram** calculation. As can be seen in the plot, the spinodal curve for BCC goes through the one-phase region for Sigma. This is because the spinodal curve for a phase is calculated when all other phases are suspended.

Project File Information

- Folder: **Property Models** → **General**
- File name: *PM_G_08_Spinodal.tcu*

Visualizations



Many of our Graphical Mode examples have video tutorials, which you can access in a variety of ways. When in Thermo-Calc, from the menu select **Help** → **Video Tutorials**, or from the main My Project window, click **Video Tutorials**. Alternately, you can go to the [website](#) or our [YouTube channel](#).

Open the example project file to review the node setup on the **Project** window and the associated settings on the **Configuration** window for each node. For some types of projects, you can also adjust settings on the **Plot Renderer Configuration** window to preview results before performing the simulation. Click **Perform Tree** to generate plots and tables to see the results on the **Visualizations** window.

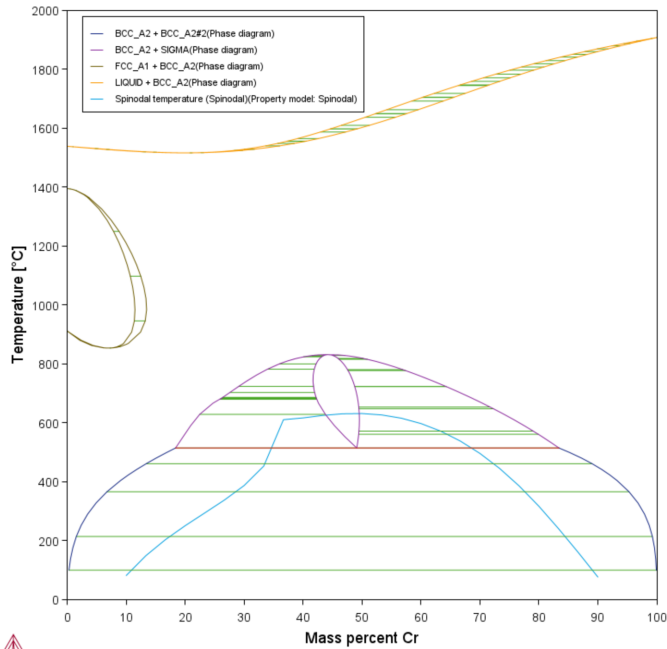

Figure 54: An Fe-Cr spinodal curve for BCC goes through the one-phase region for Sigma.

PM_G_09: T-Zero Temperature

The example uses the **Property Model Calculator** and the **T-Zero Temperature** Property Model to calculate the so-called T_0 line for the two-phase field FCC_A1 and BCC_A2 in the Fe-Ni system. The line is plotted together with the phase diagram for the same Fe-Ni system. The **FEDEMO: Iron Demo Database** is used and this example is available to all users.

The T_0 temperature is defined as the temperature where two phases of identical chemical composition have the same molar Gibbs free energy. This temperature is an important quantity in the field of diffusionless phase transformations, e.g. martensitic transformation, since it is the upper limit where diffusionless phase transformations can occur.

Two Property Model Calculators are used in this example. The T_0 line (a **One Axis** calculation) for the two-phase field FCC_A1 and BCC_A2 is overlaid on top of a the Fe-Ni **Phase diagram** calculation.

Project File Information

- Folder: **Property Models** → **General**
- File name: *PM_G_09_T-Zero_temperature.tcu*

Visualizations



Many of our Graphical Mode examples have video tutorials, which you can access in a variety of ways. When in Thermo-Calc, from the menu select **Help** → **Video Tutorials**, or from the main My Project window, click **Video Tutorials**. Alternately, you can go to the [website](#) or our [YouTube channel](#).

Open the example project file to review the node setup on the **Project** window and the associated settings on the **Configuration** window for each node. For some types of projects, you can also adjust settings on the **Plot Renderer Configuration** window to preview results before performing the simulation. Click **Perform Tree** to generate plots and tables to see the results on the **Visualizations** window.

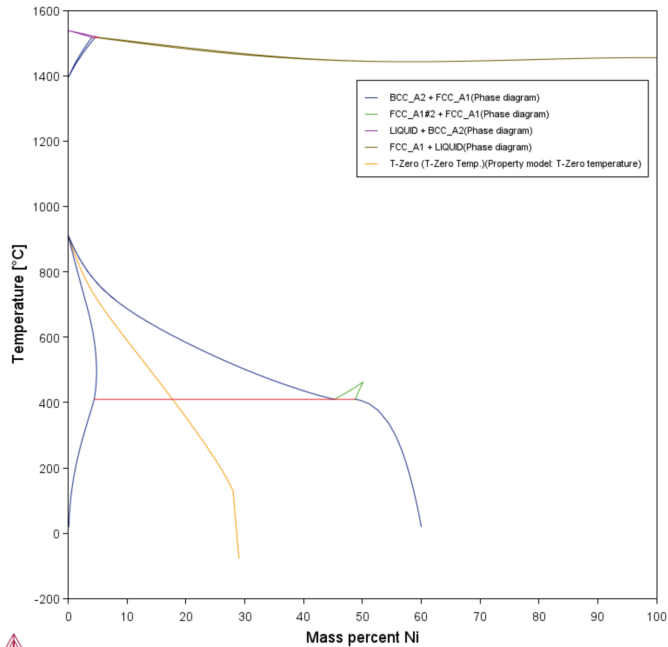

Figure 55: In this plot for the Fe-Ni system, the T_0 line for the FCC_A1 and BCC_A2 phases is located in the middle of the two-phase region. No solution for the T_0 temperature exists above about 30 mass% Ni.

PM_G_10: Freeze-in Thermal Conductivity

The example uses the **Property Model Calculator** and the **Equilibrium with Freeze-in Temperature** Property Model to compare the use of the model with thermal conductivity with and without grain boundary (GB) phase scattering being included in the calculation.

The TCS Al-based Alloy Database (TCAL) is used to evaluate a 7075_T6 alloy (Al-1.6Cu-2.5Mg-5.6Zn-0.25Fe-0.15Mn-0.23Cr-0.2Ti-0.2Si) mass%. The "T6" in the alloy name means that the alloy has been artificially peak-aged, i.e. the matrix is almost depleted. The heating is assumed to be at a typical artificial aging temperature of 150 °C. The temperature has then been increased for measuring of the reported values thermal conductivity at 400, 500, and 532 °C.

The thermal conductivity due to grain boundary phase scattering is approximated as a scattering constant times the total volume fraction of the grain boundary phases. The contribution to thermal conductivity is assumed to be related to that to electrical resistivity, following the Wiedemann-Franz law.

The calculation set up assumes that the alloy reaches equilibrium at the peak-age temperature, i.e. that the amounts of phases and their composition freeze-in at 150 °C and that these do not change for the evaluation of thermal conductivity at the temperatures 400, 500, and 532 °C. Calculations are compared between accounting and ignoring contributions from grain boundary (GB) phase scattering.

As can be seen in [Figure 56](#), the calculation including the approximate effect of grain boundary phase scattering is close to the experimentally measured values. Excluding the effect of grain boundary phase scattering slightly overestimates the thermal conductivity. Experimental data is from [2008ASM].

Project File and License Information

- Folder: **Property Models** → **General**
- File name: *PM_G_10_Freeze_In_Thermal_Conductivity.tcu*



The TCS Al-based Alloy Database (TCAL) is used in this example. A valid license for version 7 (TCAL7) or newer is required to run the example.

Visualizations



Many of our Graphical Mode examples have video tutorials, which you can access in a variety of ways. When in Thermo-Calc, from the menu select **Help** → **Video Tutorials**, or from the main My Project window, click **Video Tutorials**. Alternately, you can go to the [website](#) or our [YouTube channel](#).

Open the example project file to review the node setup on the **Project** window and the associated settings on the **Configuration** window for each node. For some types of projects, you can also adjust settings on the **Plot Renderer Configuration** window to preview results before performing the simulation. Click **Perform Tree** to generate plots and tables to see the results on the **Visualizations** window.

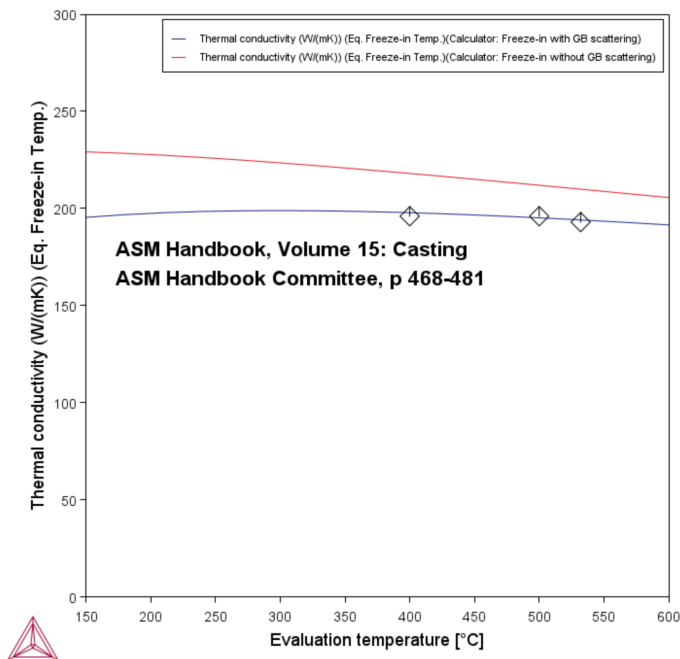

Figure 56: Comparing the freeze-in temperature for the 7075_T6 alloy with and without grain boundary (GB) scattering included in the calculations.

Reference

[2008ASM] ASM Handbook Committee, ASM Handbook Volume 15: Casting. ASM International, p. 468-481, 2008, ISBN 978-0-87170-711-6.

PM_G_11: Freeze-in Electrical Resistivity

The example uses the **Property Model Calculator** and the **Equilibrium with Freeze-in Temperature** Property Model to compare the use of the model for electrical resistivity with and without grain boundary (GB) scattering being included in the calculation.

The TCS Al-based Alloy Database (TCAL) is used to evaluate a 4032-O alloy (Al-0.9Cu-1.0Mg-0.9Ni-12.2Si) mass%. The "O" in the alloy name means that the Al alloy has been heat-treated at a typical temperature of 350 °C. The measurement of electric resistivity is usually performed at room temperature.

The electrical resistivity due to grain boundary phase scattering is approximated as a scattering constant times the total volume fraction of the grain boundary phases.

The calculation set up assumes that the alloy reaches equilibrium at the "O" heat-treated temperature, i.e. that the amounts of phases and their composition freeze-in at 350 °C and that these do not change for the evaluation of electrical resistivity at the room temperature. Calculations are compared between accounting and ignoring contributions from grain boundary (GB) scattering.

As can be seen from [Figure 57](#), the calculated electrical resistivity at room temperature, including grain boundary phase scattering, is very close to the experimentally measured value (4.3E-8) for the alloy. Excluding the grain boundary phase scattering somewhat underestimates the electrical resistivity for the alloy. Experimental data is from [1993Dav].

Project File and License Information

- Folder: **Property Models → General**
- File name: *PM_G_11_Freeze_In_Electric_Conductivity.tcu*



The TCS Al-based Alloy Database (TCAL) is used in this example. A valid license for version 7 (TCAL7) or newer is required to run the example.

Visualizations



Many of our Graphical Mode examples have video tutorials, which you can access in a variety of ways. When in Thermo-Calc, from the menu select **Help → Video Tutorials**, or from the main My Project window, click **Video Tutorials**. Alternately, you can go to the [website](#) or our [YouTube channel](#).

Open the example project file to review the node setup on the **Project** window and the associated settings on the **Configuration** window for each node. For some types of projects, you can also adjust settings on the **Plot Renderer Configuration** window to preview results before performing the simulation. Click **Perform Tree** to generate plots and tables to see the results on the **Visualizations** window.

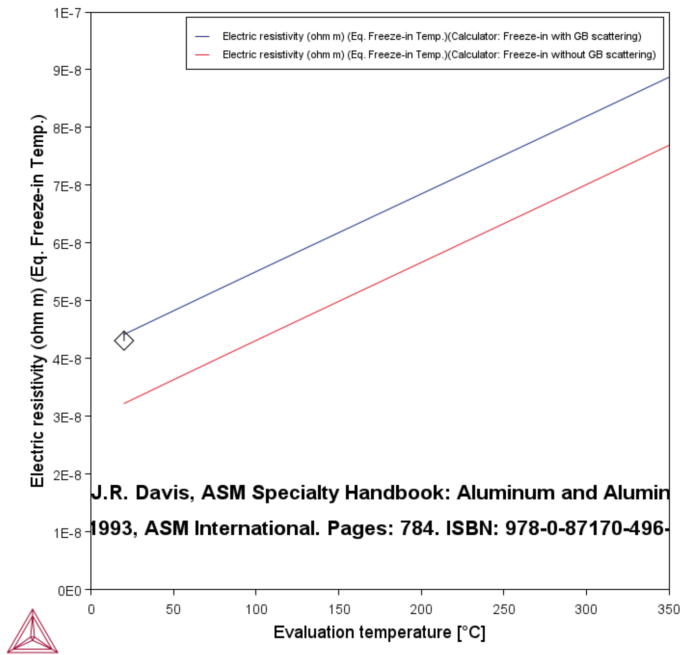

Figure 57: Comparing the freeze-in temperature for the 4032-O alloy with and without grain boundary (GB) scattering included in the calculations.

Reference

[1993Dav] J.R. Davis, ASM Specialty Handbook: Aluminum and Aluminum Alloys, 1993, ASM International. Pages: 784. ISBN: 978-0-87170-496-2.

PM_G_12: Solidus and Liquidus Batch Calculation

The example uses the **Property Model Calculator** and the **Liquidus and Solidus Temperature** Property Model to demonstrate the use of the **Batch Calculation Type**.

The thermodynamic demonstration steel database (FEDEMO) is used along with a randomized set of experimental data points that are shown on the **Configuration** window in a table. The data showing in this example is imported from a data file prepared with specific data entry requirements.

A variety of compositions for an Fe-Cr-Mn-Ni-C alloy is used for the calculations; these compositions are also taken from the same data file. When the heading includes `Exp`, then these columns are considered experimental data by Thermo-Calc, where in this example it is the columns titled `Exp Liq temp C` and `Exp Sol temp C`. This experimental data can then be plotted as a function of the calculated solidus/liquidus temperature and compared on the plot using a **Cross plot**, which is selected on the **Plot Renderer**. The limits are shown using the setting RMS (root mean square).



The experimental data entered into the batch data file is unitless even though the actual experimental data unit is Celsius (as written in the header text). In order for the plot and calculations to match, Celsius is chosen as the temperature unit when defining the **Solidus/Liquidus** Property Model and all the axes manually scaled to the same limits (1360 → 1520).

Project File Information

- Folder: **Property Models** → **General**
- File name: *PM_G_12_Solidus_and_Liquidus_Batch_Calculation.tcu*

Visualizations



This example is included as a Property Model tutorial on our [website](#) and as part of the Property Model Calculator playlist on our [YouTube channel](#).

Open the example project file to review the node setup on the **Project** window and the associated settings on the **Configuration** window for each node. For some types of projects, you can also adjust settings on the **Plot Renderer Configuration** window to preview results before performing the simulation. Click **Perform Tree** to generate plots and tables to see the results on the **Visualizations** window.

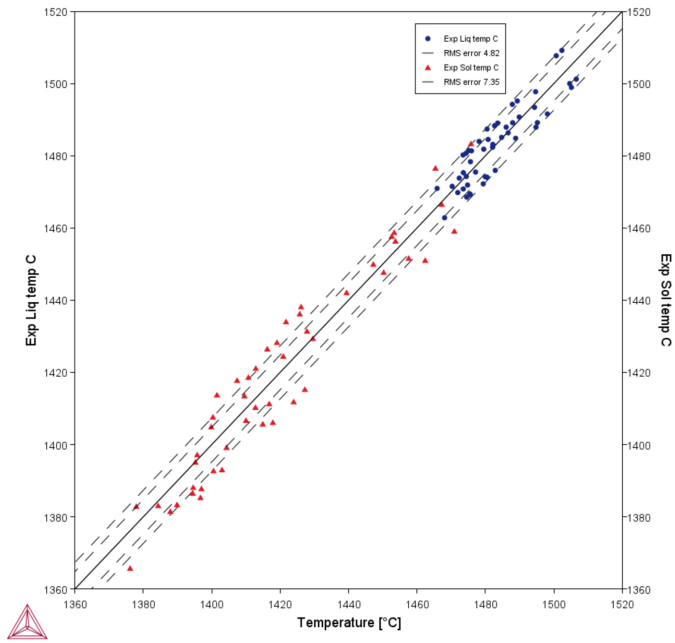

Figure 58: A comparison of experimental liquidus and solidus data using a Cross plot with a Batch calculation. A root mean square (RMS) setting shows the distribution of the data points.

PM_G_13: Ti Alloy Design for Additive Manufacturing

This in-depth example, which is [available on our website](#), uses the **Property Model Calculator** to find the optimal composition for a titanium-based alloy to be used for additive manufacturing applications.

Additive manufacturing provides new opportunities to fabricate complex parts. However, traditional alloys may not be readily printable using techniques such as laser powder bed fusion. As such, the development of new alloys may be necessary to fully realize the benefits of additive manufacturing technologies.

In this example, inspired by the work of Ackers et al. [2021Ack], **Batch** calculations within the Property Model Calculator are used to identify candidate titanium alloy chemistries for biomedical implant applications using the thermodynamic TCS Ti/TiAl-based Alloys Database (TCTI). To optimize printability and material weight, the liquidus temperature, solidus temperature, and density of 2000 randomized titanium alloy chemistries from the Ti-Nb-Zr-Sn-Ta-Fe-Mo system are calculated. An estimate of alloy cost is also made for each alloy. Taken together, this methodology can be used to identify compositions of interest and accelerate material development activities.

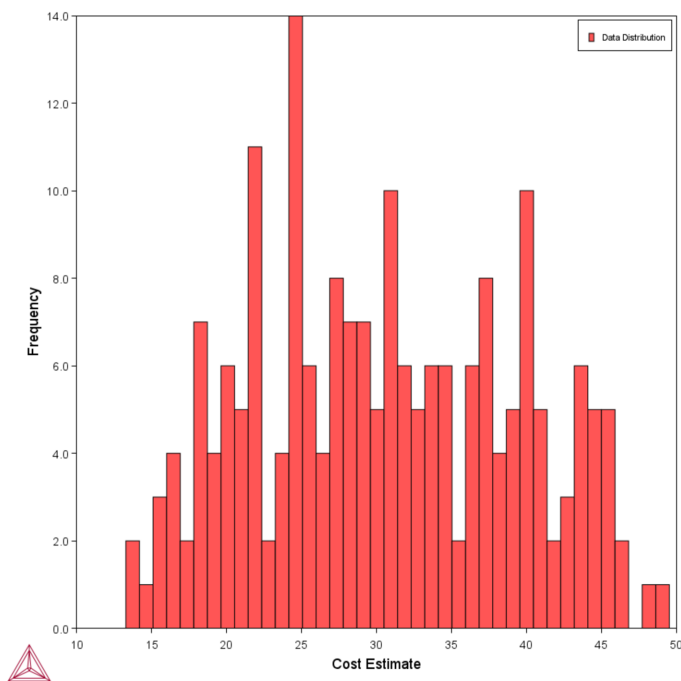

Figure 59: Cost estimate histogram for 2000 randomized chemistries from the Ti-Nb-Zr-Sn-Ta-Fe-Mo system. The cost estimate was calculated using a user-defined function in the Property Model Calculator.

Project File and License Information

- Folder: **Property Models** → **General**
- File name: *PM_G_13_Ti_Alloy_Design_for_AM.tcu*



A license for Thermo-Calc 2022b or newer and the TCS Ti/TiAl-based Alloys Database (TCTI) version 4 (TCTI4) or newer, is required to run the example.

Visualizations



Many of our Graphical Mode examples have video tutorials, which you can access in a variety of ways. When in Thermo-Calc, from the menu select **Help** → **Video Tutorials**, or from the main My Project window, click **Video Tutorials**. Alternately, you can go to the [website](#) or our [YouTube channel](#).

Open the example project file to review the node setup on the **Project** window and the associated settings on the **Configuration** window for each node. For some types of projects, you can also adjust settings on the **Plot Renderer Configuration** window to preview results before performing the simulation. Click **Perform Tree** to generate plots and tables to see the results on the **Visualizations** window.



The resulting plots and details related to setting up this example are available to download via the [dedicated web page](#).

Reference

[2021Ack] M. A. Ackers, O. M. D. M. Messé, U. Hecht, Novel approach of alloy design and selection for additive manufacturing towards targeted applications. *J. Alloys Compd.* 866, 158965 (2021).

PM_G_14: Ti-Fe T-Zero Martensite

The example uses the **Property Model Calculator** and the **T-Zero Temperature** Property Model to demonstrate the martensitic BCC \rightarrow HCP transformation for a binary Ti-Fe system. A setting is used to include a Gibbs energy addition to the second phase, which allows for the inclusion of an energy barrier for martensitic phase transformations.

Project File and License Information

- Folder: **Property Models \rightarrow General**
- File name: *PM_G_14_Ti_Fe_T-Zero_Martensite.tcu*



The TCS Ti/TiAl-based Alloys Database (TCTI) is used in this example. A valid license is required to run the example.

Visualizations



Many of our Graphical Mode examples have video tutorials, which you can access in a variety of ways. When in Thermo-Calc, from the menu select **Help \rightarrow Video Tutorials**, or from the main My Project window, click **Video Tutorials**. Alternately, you can go to the [website](#) or our [YouTube channel](#).

Open the example project file to review the node setup on the **Project** window and the associated settings on the **Configuration** window for each node. For some types of projects, you can also adjust settings on the **Plot Renderer Configuration** window to preview results before performing the simulation. Click **Perform Tree** to generate plots and tables to see the results on the **Visualizations** window.

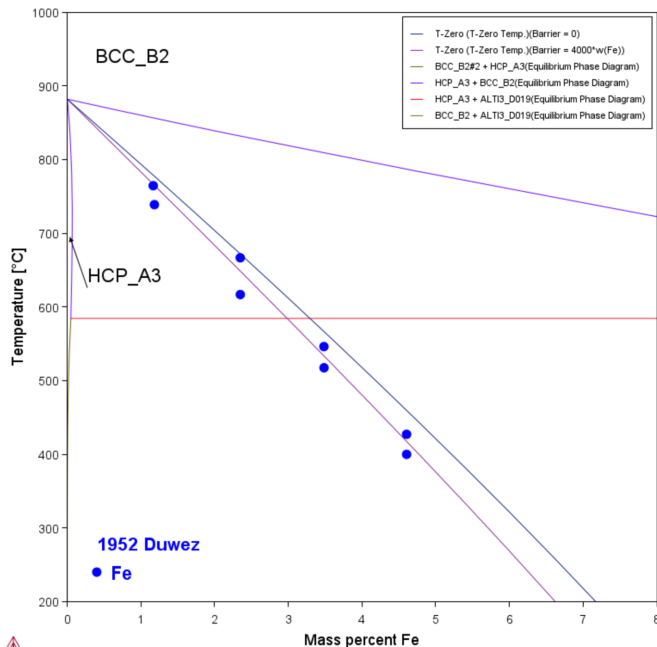

Figure 60: The T-Zero (barrier = 0) line is the temperature without energy addition, the solid blue line is the T-Zero temperature with an energy addition of $4000 \cdot w(\text{Fe})$ [J/mol], that well reproduces the experimental data from Duwez (1952).

Reference

[1952Duz] P. Duwez, "The Martensite Transformation Temperature in Titanium Binary Alloys, Third Technical Report" (U.S. Atomic Energy Commission, 1952).

PM_G_15: Columnar to Equiaxed Transition (CET) of a NiAlCr Alloy

This example uses the **Property Model Calculator** and the **Columnar to Equiaxed Transition** Property Model with nickel demo databases to mimic the result of CMSX-4 alloy, which compares the tip radius and undercooling with growth velocity.

A Ni-26Al-9Cr (at.%) alloy is used so that its calculated undercooling is close to that of a 10-component CMSX-4 alloy. A **One Axis** calculation for the FCC_L12 primary phase is done using the CET parameters entered on the **Property Model Calculator Configuration** window.

The settings used are the same as those from the literature [2001Gäu], i.e.:

- **Number of nucleation sites:** $2.0 \times 10^{15} / \text{m}^3$
- **Equiaxed exponent:** 3.4
- **Nucleation undercooling:** 2.5 K
- **Solve for:** Thermal gradient
- **Equiaxed fractions:** 0.0066 0.1

Project File Information

- Folder: **Property Models** → **General**
- File name: *PM_G_15_Ni-Al-Cr_Columnar_Equiaxed_Transition.tcu*



The NIDEMO and MNIDEMO databases are used in this example and it is available to all users.



Also see these examples that use the same Property Model. However, these examples require licenses as they use the TCS Ni-based Superalloys Database (TCNI) and TCS Ni-alloys Mobility Database (MOBNI): "PM_G_16: Columnar to Equiaxed Transition of a CMSX-4 Alloy" on page 99 and "PM_G_17: Columnar to Equiaxed Transition of an IN718 Alloy" on page 103.

Visualizations



Many of our Graphical Mode examples have video tutorials, which you can access in a variety of ways. When in Thermo-Calc, from the menu select **Help** → **Video Tutorials**, or from the main My Project window, click **Video Tutorials**. Alternately, you can go to the [website](#) or our [YouTube channel](#).

Open the example project file to review the node setup on the **Project** window and the associated settings on the **Configuration** window for each node. For some types of projects, you can also adjust settings on the **Plot Renderer Configuration** window to preview results before performing the simulation. Click **Perform Tree** to generate plots and tables to see the results on the **Visualizations** window.

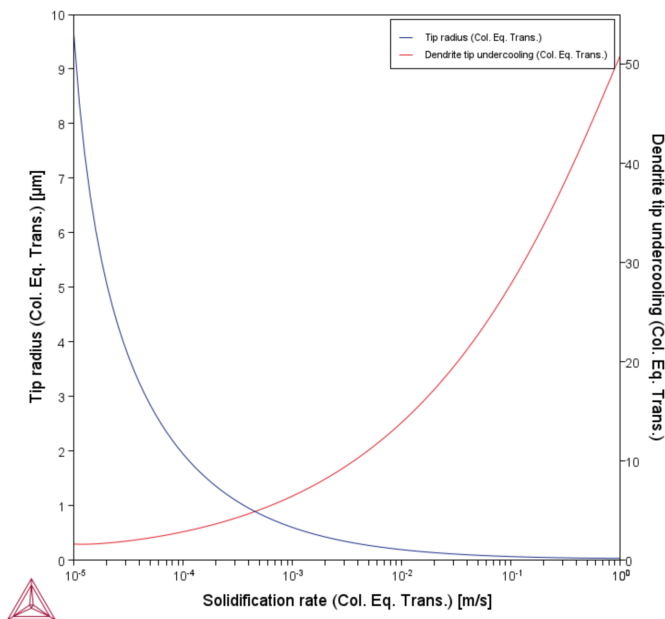

Figure 61: Tip radius and undercooling vs growth velocity for a Ni-26Al-9Cr alloy.

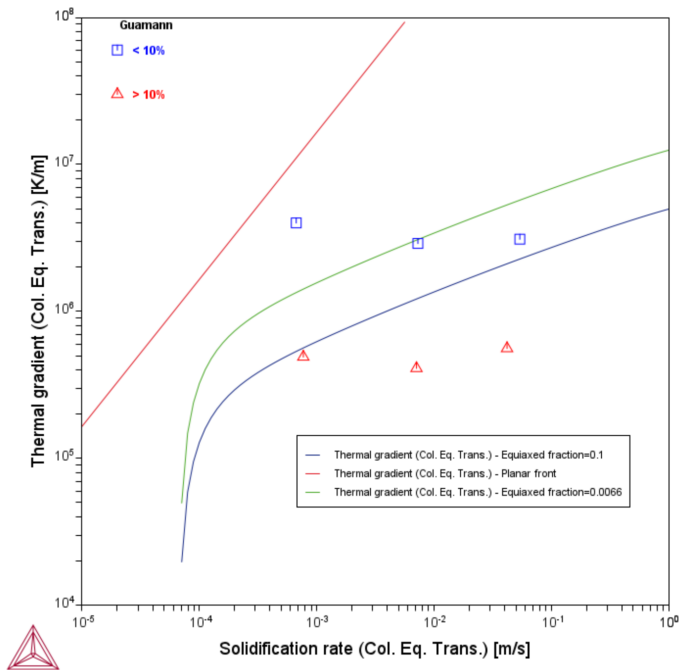

Figure 62: CET curves for a Ni-26Al-9Cr alloy using experimental data from [2001Gäu]. Also see PM_G_16 to compare the results to the CMSX-4 alloy results.

Reference

[2001Gäu] M. Gäumann, C. Bezençon, P. Canalis, W. Kurz, Single-crystal laser deposition of superalloys: processing–microstructure maps. *Acta Mater.* 49, 1051–1062 (2001).

PM_G_16: Columnar to Equiaxed Transition of a CMSX-4 Alloy

This example uses the **Property Model Calculator** and the **Columnar to Equiaxed Transition** Property Model with a CMSX-4 alloy to compare calculated CET curves to experimental data.

A 10-component system, with a composition from Gäumann et al. [2001Gäu], is used for this simulation of a CMSX-4 alloy.

Alloy composition of CMSX-4 [2001Gäu].

	<i>Co</i>	<i>Cr</i>	<i>Al</i>	<i>Ti</i>	<i>W</i>	<i>Ta</i>	<i>Re</i>	<i>Hf</i>	<i>Mo</i>	<i>Ni</i>
wt.%	9.0	6.5	5.6	1.0	6.0	6.5	3.0	0.1	0.6	Bal
at.%	9.262	7.581	12.587	1.267	1.979	2.178	0.977	0.034	0.379	Bal

The results are compared with literature data (epitaxial laser metal forming) and the original model [1999Gäu; 2001Gäu].

A **One Axis** calculation for the FCC_L12 primary phase is done using the CET parameters entered on the **Property Model Calculator Configuration** window.

The settings entered include:

- **Interfacial energy:** 0.25 J/m^2 , which gives a Gibbs-Thomson coefficient of $1.87 \times 10^{-7} \text{ mK}$, in agreement with the literature [2001Gäu].
- **Number of nucleation sites:** $2.0 \times 10^{15} / \text{m}^3$
- **Nucleation undercooling:** 3.0 K
- **Equiaxed exponent:** 3.4
- **Solve for:** Thermal gradient
- **Equiaxed fractions:** $0.0066 \quad 0.1$

In the calculation, the nucleation undercooling is slightly larger than originally used (2.5 K) [2001Gäu], since it has been found that at a low speed limit, the Property Model gives an undercooling close to 3 K .



The original value is arbitrary and does not affect the results at a high speed range.

Project File and License Information

- Folder: **Property Models** → **General**
- File name: *PM_G_16_CMSX-4_Columnar_Equiaxed_Transition.tcu*



To run this example requires a license for the TCS Ni-based Superalloys Database (TCNI) version 12 (TCNI12) or newer and the TCS Ni-alloys Mobility Database (MOBNI) version 6 (MOBNI6) or newer.



Example "PM_G_15: Columnar to Equiaxed Transition (CET) of a NiAlCr Alloy" on page 96 uses demo databases available to everyone and mimics this alloy in its results.

Visualizations



Many of our Graphical Mode examples have video tutorials, which you can access in a variety of ways. When in Thermo-Calc, from the menu select **Help** → **Video Tutorials**, or from the main My Project window, click **Video Tutorials**. Alternately, you can go to the [website](#) or our [YouTube channel](#).

Open the example project file to review the node setup on the **Project** window and the associated settings on the **Configuration** window for each node. For some types of projects, you can also adjust settings on the **Plot Renderer Configuration** window to preview results before performing the simulation. Click **Perform Tree** to generate plots and tables to see the results on the **Visualizations** window.

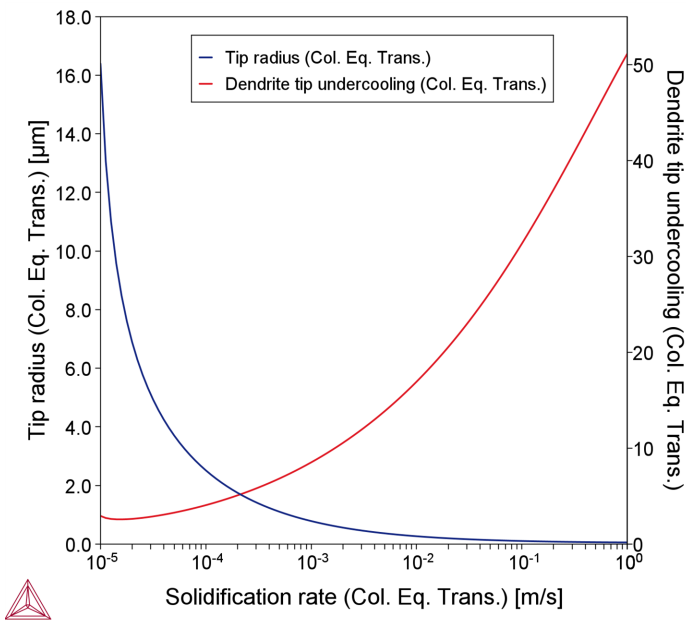

Figure 63: Tip radius and undercooling vs growth velocity for a CMSX-4 alloy.

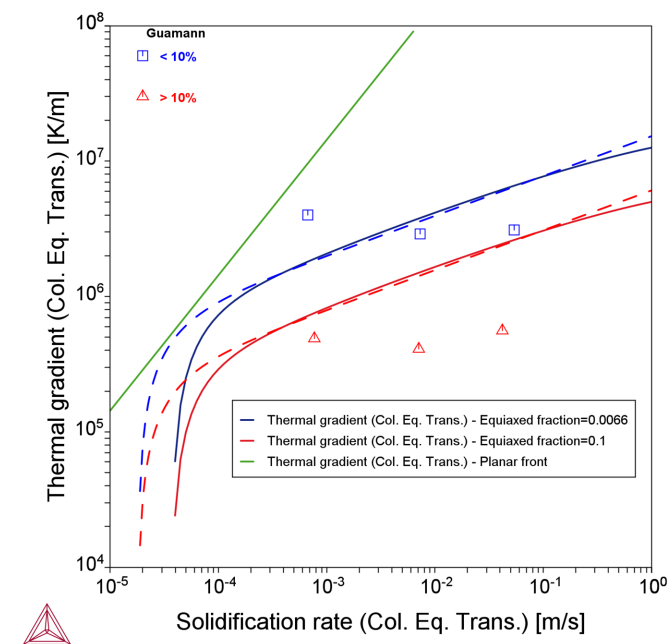

Figure 64: Calculated CET curves (solid lines) in comparison to experimental data (data points) and calculations (dashed lines) from the literature [2001Gäu].

References

[1999Gäu] M. Gäumann, PhD thesis, Epitaxial laser metal forming of a single crystal superalloy, École polytechnique fédérale de Lausanne (EPFL) (1999).

[2001Gäu] M. Gäumann, C. Bezençon, P. Canalis, W. Kurz, Single-crystal laser deposition of superalloys: processing–microstructure maps. *Acta Mater.* 49, 1051–1062 (2001).

More Information



Also see these examples that use the same Property Model: "[PM_G_15: Columnar to Equiaxed Transition \(CET\) of a NiAlCr Alloy](#)" on page 96 and "[PM_G_17: Columnar to Equiaxed Transition of an IN718 Alloy](#)" on the next page.

PM_G_17: Columnar to Equiaxed Transition of an IN718 Alloy

The example uses the **Property Model Calculator** and the **Columnar to Equiaxed Transition** Property Model to compare calculated CET curves for an IN718 alloy to experimental data.

A **One Axis** calculation for the FCC_L12 primary phase is done using the CET parameters entered on the **Property Model Calculator Configuration** window.

The settings entered include:

- **Interfacial energy:** 0.5 J/m².
- **Number of nucleation sites:** 4.0E11/m³
- **Nucleation undercooling :** 4.0 K
- **Equiaxed exponent:** 3.13
- **Solve for:** Thermal gradient
- **Equiaxed fractions:** 0.01 0.49 0.99

The literature data from Polonsky et al. [2020Pol] are not purely experimental data, but rather combined with experimental equiaxed evidence and model calculations with numerical values of thermal gradients, growth velocity as well as tip undercooling. Polonsky et al. estimated tip undercooling based on a Scheil calculation, which smeared out the composition inhomogeneity at the dendrite front, hence underestimating the undercooling. Since both tip undercooling and nucleation site density promotes the formation of equiaxed crystals, an increase in undercooling in this example calculation leads to a decrease in nucleation site density compared to the results in [2020Pol] if one were fitting the same set of data.

Project File and License Information

- Folder: **Property Models** → **General**
- File name: *PM_G_17_IN718_Columnar_Equiaxed_Transition.tcu*



To run this example requires a license for the TCS Ni-based Superalloys Database (TCNI) version 12 (TCNI12) or newer and the TCS Ni-alloys Mobility Database (MOBNI) version 6 (MOBNI6) or newer.



Example "PM_G_15: Columnar to Equiaxed Transition (CET) of a NiAlCr Alloy" on page 96 uses demo databases available to everyone.

Visualizations



Many of our Graphical Mode examples have video tutorials, which you can access in a variety of ways. When in Thermo-Calc, from the menu select **Help** → **Video Tutorials**, or from the main My Project window, click **Video Tutorials**. Alternately, you can go to the [website](#) or our [YouTube channel](#).

Open the example project file to review the node setup on the **Project** window and the associated settings on the **Configuration** window for each node. For some types of projects, you can also adjust settings on the **Plot Renderer Configuration** window to preview results before performing the simulation. Click **Perform Tree** to generate plots and tables to see the results on the **Visualizations** window.

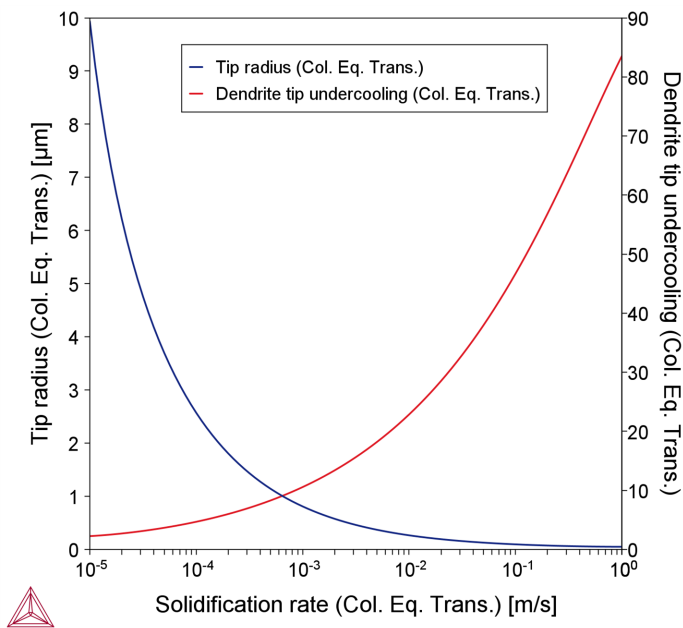

Figure 65: Tip radius and undercooling vs growth velocity for an IN718 alloy.

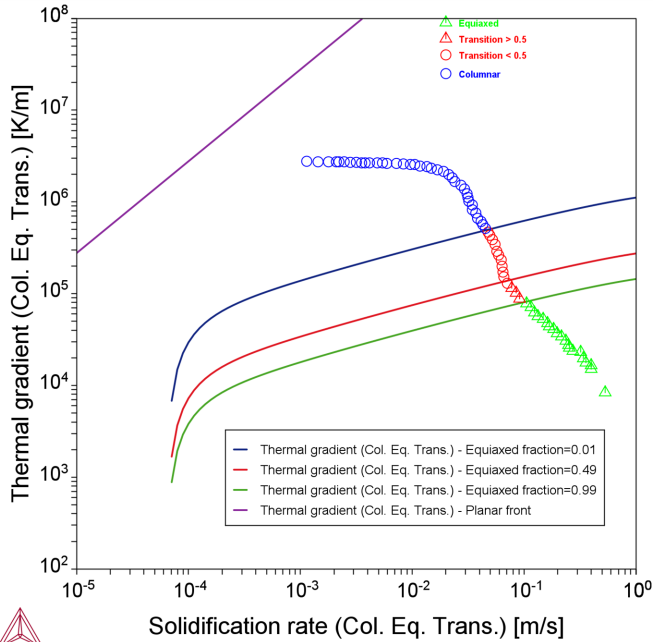

Figure 66: Calculated CET curves for IN718 in comparison with literature data [2020Pol].

Reference

[2020Pol] A. T. Polonsky, N. Raghavan, M. P. Echlin, M. M. Kirka, R. R. Dehoff, T. M. Pollock, 3D Characterization of the Columnar-to-Equiaxed Transition in Additively Manufactured Inconel 718, in *Superalloys 2020* (2020), pp. 990–1002.

More Information



Also see these examples that use the same Property Model: "PM_G_15: Columnar to Equiaxed Transition (CET) of a NiAlCr Alloy" on page 96 and "PM_G_16: Columnar to Equiaxed Transition of a CMSX-4 Alloy" on page 99.

PM_G_18: Equilibrium and Annealing Heat Treatment for ASTM A29

This example uses the **Property Model Calculator** and the **Equilibrium** Property Model and calculates the equilibrium for the provided conditions. The calculation result from this model is the same as when you are using the Equilibrium Calculator with the Single Equilibrium calculation type, but this model is preferable when min/max or uncertainty calculations are required in case of compositional variations, which is true for most engineering materials.

An example for choosing annealing heat treatments for a medium carbon low alloyed AISI 4130 steel is shown. The alloy has the following composition, as per ASTM A29 standard:

<i>Fe</i>	<i>C</i>	<i>Mn</i>	<i>P</i>	<i>S</i>	<i>Si</i>	<i>Cr</i>	<i>Mo</i>
Rem.	0.28-0.33	0.40-0.60	0.035	0.040	0.15-0.35	0.80-0.10	0.15-0.25

The Equilibrium Model in this example is calculated for uncertainty in chemical compositions and annealing temperatures (820-900 °C) to optimize for formation of austenite phase (FCC_A1). This is done to achieve a microstructure suitable for machining. It is seen that best probabilistic results are achieved around 860 °C, which agrees well with the industrially applied process.

Project File Information

- Folder: **Property Models** → **General**
- File name: *PM_G_18_Equilibrium.tcu*



This uses the latest versions of TCS Steel and Fe-alloys Database (TCFE) (TCFE14) and TCS Steels/Fe-Alloys Mobility Database (MOBFE) (MOBFE8). Valid licenses are required to run the example. Earlier versions can be used but there will be slight differences to the results.

Visualizations



Many of our Graphical Mode examples have video tutorials, which you can access in a variety of ways. When in Thermo-Calc, from the menu select **Help** → **Video Tutorials**, or from the main My Project window, click **Video Tutorials**. Alternately, you can go to the [website](#) or our [YouTube channel](#).

Open the example project file to review the node setup on the **Project** window and the associated settings on the **Configuration** window for each node. For some types of projects, you can also adjust settings on the **Plot Renderer Configuration** window to preview results before performing the simulation. Click **Perform Tree** to generate plots and tables to see the results on the **Visualizations** window.

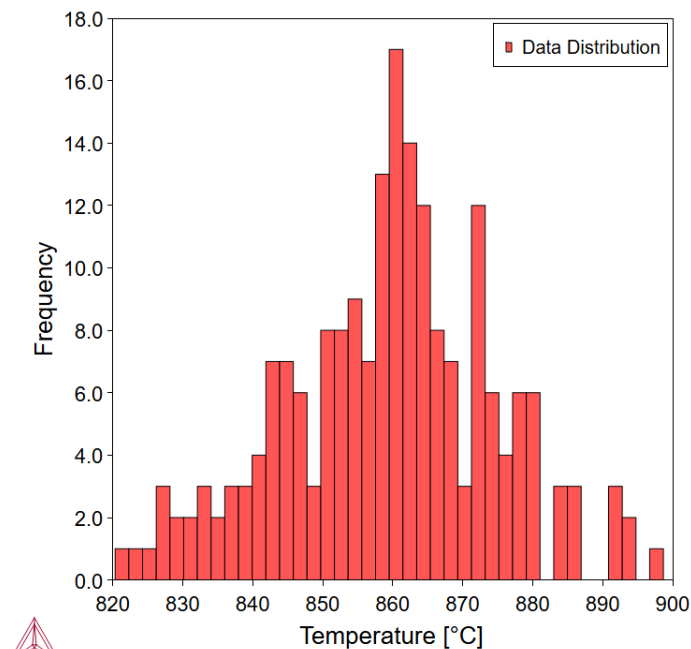

Figure 67: Histogram of evaluation temperature used for equilibrium calculations. The data maintains the shape of a normal distribution, indicating that all sampled calculations pass the applied filter.

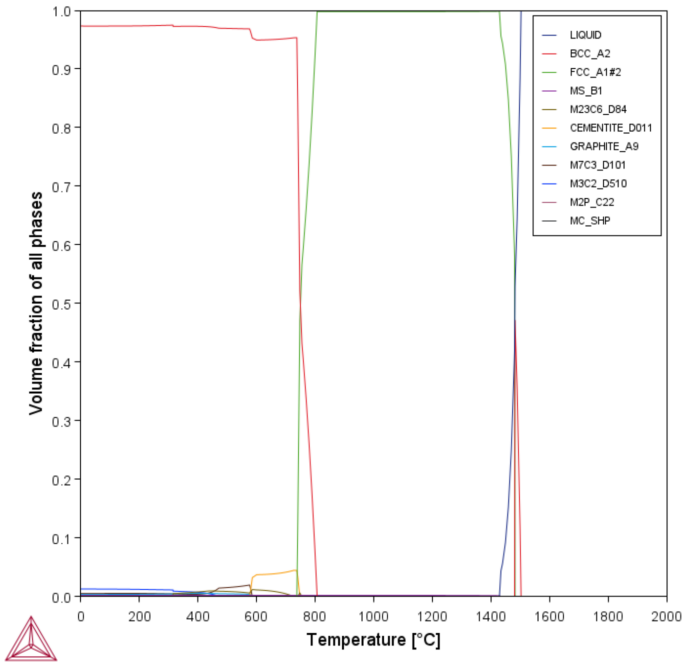

Figure 68: One axis equilibrium diagram of AISI 4130 steel using the average composition per ASTM A29. The region where Austenite (FCC_A1#2 in this diagram) is stable ranges from ~ 740 °C to ~ 1480 °C.

PM_G_19: Thermal Conductivity for an AM Cu-Alloy

This example uses the **Property Model Calculator** and the **Equilibrium with Freeze-in Temperature**. The Equilibrium with Freeze-in Temperature Model calculates equilibrium at the freeze-in temperature and evaluates the properties at a different temperature. This model is particularly relevant for estimating thermophysical properties such as thermal or electrical conductivities. The assumption in this model is that diffusion and phase transformations are negligible when changing from the freeze-in-temperature and, therefore, that the phase amounts and compositions of phases are kept at all other temperatures.

Project File Information

- Folder: **Property Models** → **General**
- File name: *PM_G_19_Equilibrium-With-Freezein.tcu*



This uses the latest version of TCS Cu-based Alloys Database (TCCU) (TCCU6). A valid license is required to run the example. Earlier versions can be used but there will be slight differences to the results.

Visualizations



Many of our Graphical Mode examples have video tutorials, which you can access in a variety of ways. When in Thermo-Calc, from the menu select **Help** → **Video Tutorials**, or from the main My Project window, click **Video Tutorials**. Alternately, you can go to the [website](#) or our [YouTube channel](#).

Open the example project file to review the node setup on the **Project** window and the associated settings on the **Configuration** window for each node. For some types of projects, you can also adjust settings on the **Plot Renderer Configuration** window to preview results before performing the simulation. Click **Perform Tree** to generate plots and tables to see the results on the **Visualizations** window.

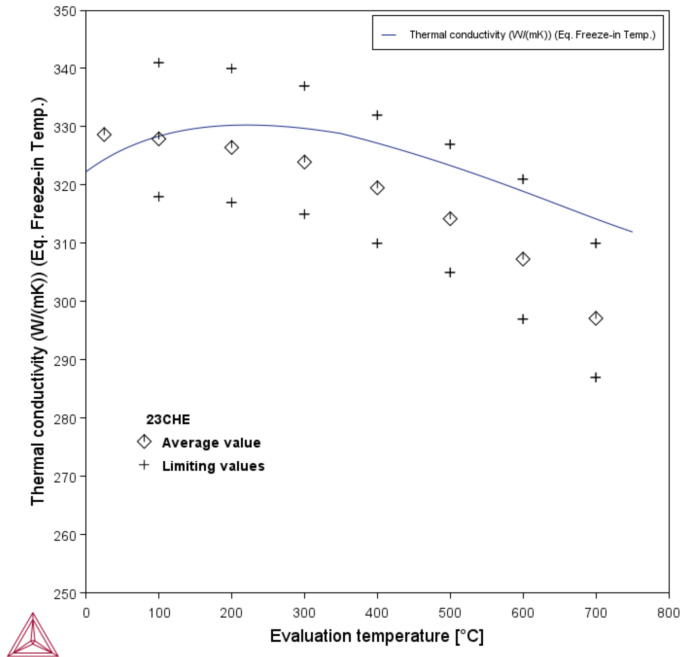

Figure 69: The thermal conductivity (W/m.K) as a function of temperature (°C) for an additively manufactured Cu alloy (GRCop-42), which was developed by NASA for application in rocket engine combustion chamber liners. The values are compared against literature values [2023Che] and show a good fit.

Reference

[2023Che] Y. Chen, C. Zeng, H. Ding, S. Emanet, P. R. Gradl, D. L. Ellis, S. Guo, Thermophysical properties of additively manufactured (AM) GRCop-42 and GRCop-84. Mater. Today Commun. 36, 106665 (2023).

PM_G_20: Scheil for an Al-1Si-1Mn-0.7Mg-0.6Fe-0.1Cu Alloy

This example uses the **Property Model Calculator** and the **Scheil** Property Model. The Scheil Property Model calculates solidification under the Scheil assumption. This Property Model is essentially the same as the Scheil Calculator included in the software, but implementing Scheil as a Property Model allows users to benefit from the additional calculation types available in the Property Model Calculator, including multi-axis Grid, Min/Max, Uncertainty, and Batch.

Project File Information

- Folder: **Property Models** → **General**
- File name: *PM_G_20_Scheil.tcu*



The TCS Al-based Alloy Database (TCAL) (TCAL9) and TCS Al-alloys Mobility Database (MOBAL) (MOBAL8) are used in this example. Valid licenses are required to run the example. Earlier versions can be used but there will be slight differences to the results.

Visualizations



Many of our Graphical Mode examples have video tutorials, which you can access in a variety of ways. When in Thermo-Calc, from the menu select **Help** → **Video Tutorials**, or from the main My Project window, click **Video Tutorials**. Alternately, you can go to the [website](#) or our [YouTube channel](#).

Open the example project file to review the node setup on the **Project** window and the associated settings on the **Configuration** window for each node. For some types of projects, you can also adjust settings on the **Plot Renderer Configuration** window to preview results before performing the simulation. Click **Perform Tree** to generate plots and tables to see the results on the **Visualizations** window.

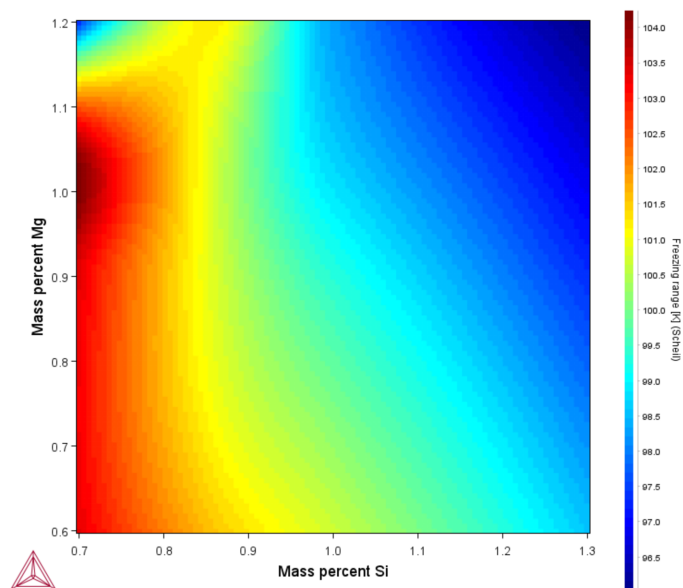

Figure 70: The heatmap plot considers an Al-1Si-1Mn-0.7Mg-0.6Fe-0.1Cu alloy wherein the freezing range is plotted with respect to changing chemical composition of Si (0.7-1.3 wt%) and Mg (0.6-1.2 wt%).

Additive Manufacturing (AM) Module Examples Collection



A separate license is required to perform calculations with the Additive Manufacturing (AM) Module. Without a license you are in *Demo Mode* where you can, for example, open and view example set ups, run some examples, add templates and nodes to the Project window, adjust some Configuration settings, and preview some functionality on the Visualizations window.



Read more about the [Additive Manufacturing \(AM\) Module](#) on our website including the details about database compatibility or to watch an [introductory webinar](#). You can also use the [Getting Started Guide](#) to learn about the key features available.

In this section:

AM_01: Transient Simulation of a Single Track	115
AM_02: Transient and Steady-state Simulations of a Single Track	121
AM_03: Steady-state Simulations	127
AM_04: Scheil Transient Steady-state	132
AM_05: Using AM Calculator Probe Data with the Diffusion Module (DICTRA)	139
AM_06a: Calibrating a Heat Source for a 316L Steel	148
AM_06b: Using the Calibrated Heat Source for a 316L Steel	154
AM_07: Batch Calculations for an IN718 Alloy	159
AM_08a: Grid Calculation for a Ti64 Alloy	165
AM_08b: Batch Calculations for a Ti64 Alloy	171
AM_09a: Grid Calculation for an SS316L Alloy	177
AM_09b: Batch Calculations for an SS316L Alloy	183
AM_10: CET Transition in an IN718 Alloy	189

AM_11: Comparing Single Tracks Printed on Casted and LPBF Substrates	194
AM_12: Using AM Calculator Probe Data with the Precipitation Module (TC-PRISMA)	205
AM_13: Using the Core-ring Beam Shape	213
AM_14: Using the Top-hat Beam Shape	221
AM_15: Electron Beam Melting in an IN718 Alloy	229

AM_01: Transient Simulation of a Single Track

The following example is part of a series showing some of the features of the Additive Manufacturing (AM) Module and the **AM Calculator**. In this example, a single track simulation is performed using the **Transient** model of the AM Calculator.

Project File and License Information

- Folder: **Additive Manufacturing**
- File name: `AM_01_Transient_DE_No_Marangoni.tcu`



A separate license is required to perform calculations with the Additive Manufacturing (AM) Module. Without a license you are in *Demo Mode* where you can, for example, open and view example set ups, run some examples, add templates and nodes to the Project window, adjust some Configuration settings, and preview some functionality on the Visualizations window.



Some examples (AM_01, AM_02, AM_03, and AM_06b) are available to all users. These examples can be run without an additional Additive Manufacturing license when you are in DEMO (demonstration) mode. However, the AM Module is not available with the Educational version of Thermo-Calc. Search the help for Available Options with the Additive Manufacturing (AM) Module.

Material Properties

These properties are the same for both AM_01 and AM_02 [2021Gra].

- Inconel 738LC: Ni-15.8 Cr-8.6 Co-2.7 W-3.3 Ti-3.6 Al-1.8 Ta-1.8 Mo-0.04 Fe-0.8 Nb-0.002 Mn-0.1 C Mass percent.
- Database: TCNI12
- The material property was pre-calculated, and stored as a built-in material library of the Additive Manufacturing (AM) Module.

Model Configuration

The transient model solves for the heat equation in the entire 3D domain, including the melt pool, and is therefore, computationally expensive to solve. The fluid flow inside the melt pool due to the Marangoni effect is not included in this example. The double ellipsoidal, or the so-called Goldak heat source model, is used to predict melt pool size and temperature distribution during single track scanning. The parameters for the double ellipsoidal heat source are computed using optimization in a steady-state case for the given process parameters (power and scanning speed) and the melt pool size reported in the paper by Grange et al. [2021Gra]. The resulting parameters are shown in [Figure 71](#).

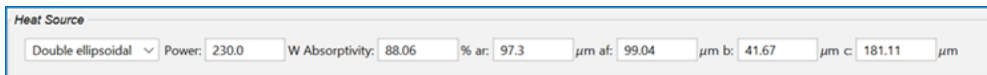

Parameter	Value
Heat Source Type	Double ellipsoidal
Power	230.0 W
Absorptivity	88.06 %
ar	97.3
μm af	99.04
μm b	41.67
μm c	181.11

Figure 71: Optimized heat source parameters entered on the AM Calculator for the experiment given in Grange et al. [2021Gra] with power = 230 W and scanning speed = 960 mm/s.

The geometry for a transient simulation, as given in the paper by Grange et al. [2021Gra], is shown in [Figure 72](#). The base plate is 2 mm in length, 0.5 mm in width, and with a thickness of 0.95 mm. A layer of powder with a thickness of 55 μm is deposited on the solid substrate. The powder layer, however, has the same material properties as the solid substrate. The laser beam with a power of 230 W develops linear scanning with constant velocity 960 mm/s. The trajectory evolves from initial position (x, y) = (0.25, 0.25) mm to final position (1.75, 0.25) mm on the top surface.

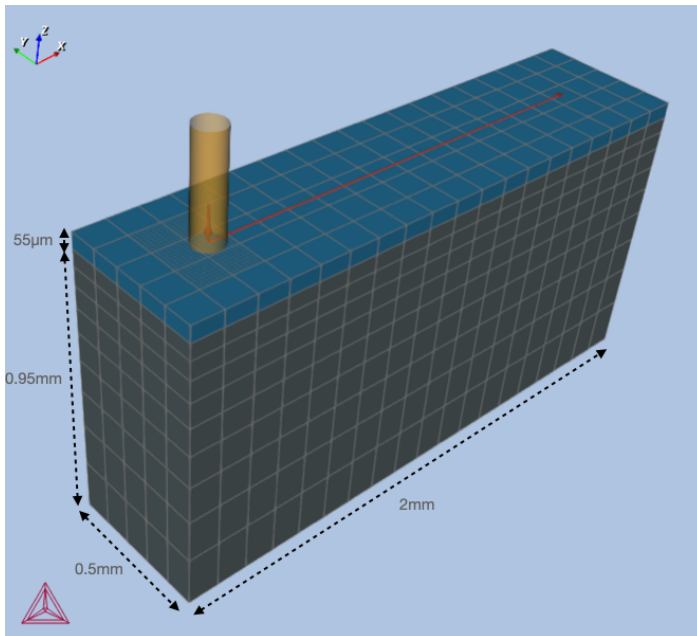

Figure 72: The geometry used for the Additive Manufacturing (AM) Module examples AM_01 and AM_02.

Two probes monitor the temporal evolution of temperature at positions shown in [Figure 73](#). The results can be presented by tabulated data or as 2D graph plots.

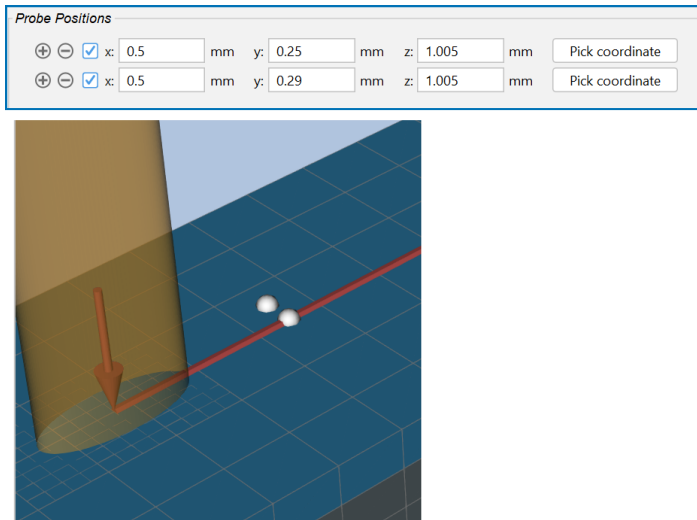

Figure 73: Probe positions for Probes P1 and P2, where P1 is placed exactly on the scanning track while P2 is placed at a distance of 0.04 mm from the track, as shown in a close up of the probes on the Visualizations window.

Visualizations

Open the example project file to review the node setup on the **Project** window and the associated settings on the **Configuration** window for each node. For some types of projects, you can also adjust settings on the **Plot Renderer Configuration** window to preview results before performing the simulation. Click **Perform Tree** to generate plots and tables to see the results on the **Visualizations** window.



When you run (Perform) this example, it takes at least 30 minutes for the calculations to complete.

There is a variety of information shown in the **Visualizations** window that can be viewed during configuration and after performing the calculation(s).

- **Geometry:** View the geometry and adjust parameters visually by changing inputs on the Configuration window. Add probes needed.
- Melt pool and other dynamically changing features can also be visualized and changed.
- **Plot** results: After completing the set up and performing the calculation, to view the matching name of the node on tab(s) in the **Visualizations** window, click a **Plot Renderer** node in the **Project** window or click the tabs individually in the **Visualizations** window.

In the surface plot it shows the temperature distribution after the scanning process is completed. It is noted that the melt pool shape reaches a steady-state when the laser beam approaches the end of the scanning track. The melt pool dimensions at the end of scanning track is given in the table.

Melt Pool Dimension	Size (mm)
Width	0.125
Depth	0.144
Length	1.12



If you are in the project file, click the **Probe plot** node in the Project window and the **3D Plot** tab in the Visualizations window.

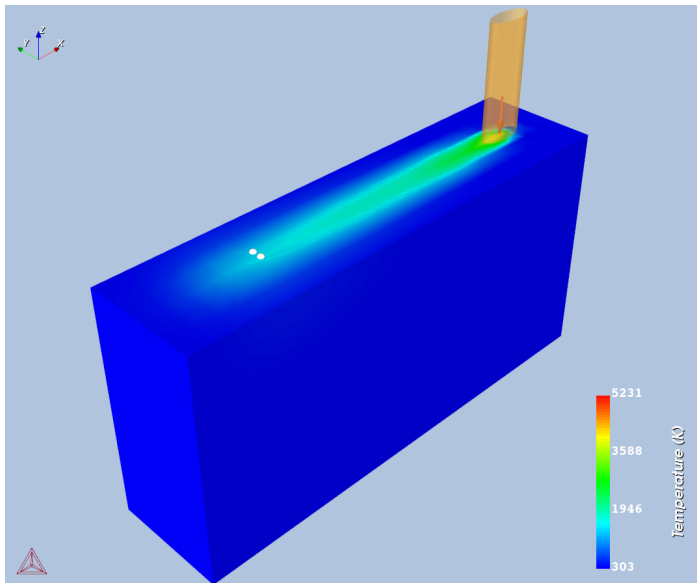

Figure 74: Surface plot of temperature distribution after the single track scan is completed. Probes P1 and P2 can also be seen on the top surface.

It is also possible to plot quantities at different cross-sections inside the domain by selecting the **Slice** checkbox on the **Plot Renderer Configuration** window under the **3D Plot** tab. The next figure shows the temperature slices plotted at cross-sections orthogonal to the scanning direction.

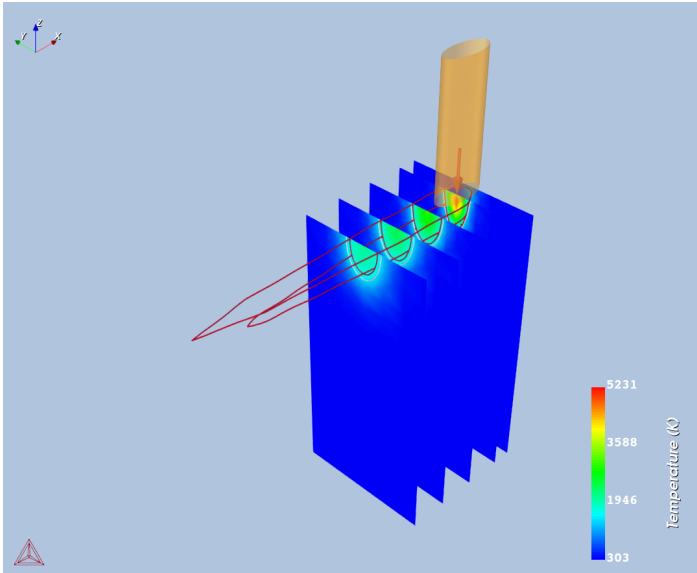

Figure 75: Slices of the computational domain, orthogonal to the scanning direction, showing temperature distribution at different cross-sections. Red tubes show the contour of the melt pool (at liquidus temperature).

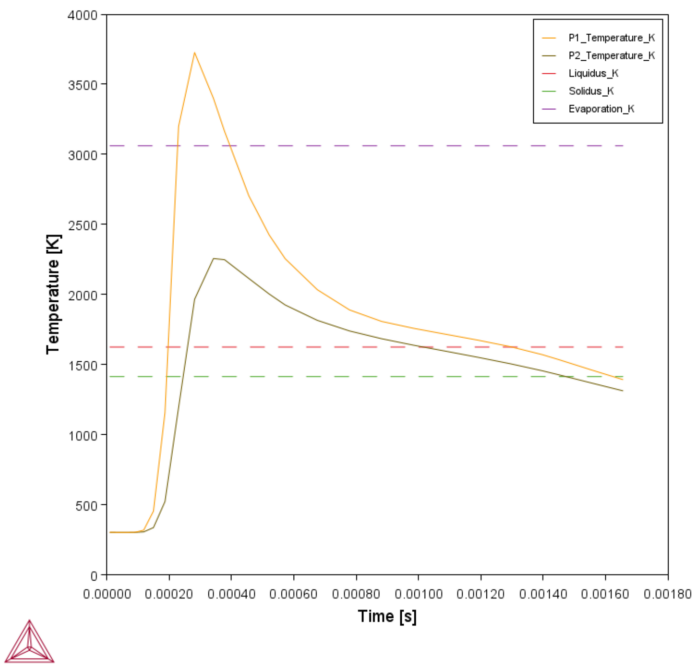

Figure 76: 2D probe plot showing temperature evolution as a function of time at probes P1 and P2.

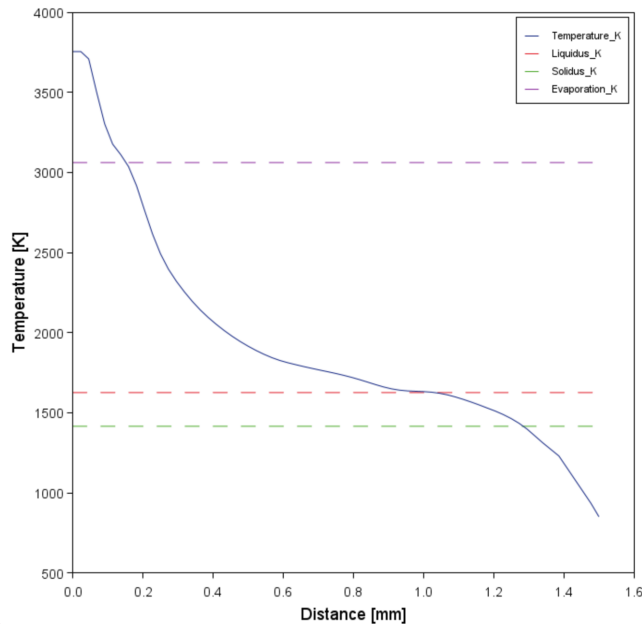

Figure 77: 2D plot over line showing temperature in the tail of the melt pool as a function of distance plotted along the scanning track.

Reference

[2021Gra] D. Grange, A. Queva, G. Guillemot, M. Bellet, J.-D. Bartout, C. Colin, Effect of processing parameters during the laser beam melting of Inconel 738: Comparison between simulated and experimental melt pool shape. J. Mater. Process. Technol. 289, 116897 (2021).

Other Resources



Read more about the [Additive Manufacturing \(AM\) Module](#) on our website including the details about database compatibility or to watch an [introductory webinar](#). You can also use the [Getting Started Guide](#) to learn about the key features available.



Many of our Graphical Mode examples have video tutorials, which you can access in a variety of ways. When in Thermo-Calc, from the menu select **Help** → **Video Tutorials**, or from the main My Project window, click **Video Tutorials**. Alternately, you can go to the [website](#) or our [YouTube channel](#).

AM_02: Transient and Steady-state Simulations of a Single Track

The following example is part of a series showing some of the features of the Additive Manufacturing (AM) Module and the **AM Calculator**. This example builds on the work done by Grange et al. [2021Gra] and is similar to example AM_01. The difference however is that in this example a single track simulation is performed using **Transient with heat source from Steady-state** model instead of the **Transient** model.

The **Transient with heat source from Steady-state** model exploits the assumption that the melt pool size and temperature distribution reaches a steady-state almost instantly and thus first solves for a **Steady-state** case with the given process parameters. The result from the **Steady-state** in the form of temperature distribution in the melt pool is then mapped as a heat source in the transient simulation. This novel approach is much faster and efficient than the approach used in example AM_01 where the heat equation is solved in the entire 3D domain.

Project File and License Information

- Folder: **Additive Manufacturing**
- File name: AM_02_TransientSS_DE.tcu



A separate license is required to perform calculations with the Additive Manufacturing (AM) Module. Without a license you are in *Demo Mode* where you can, for example, open and view example set ups, run some examples, add templates and nodes to the Project window, adjust some Configuration settings, and preview some functionality on the Visualizations window.



Some examples (AM_01, AM_02, AM_03, and AM_06b) are available to all users. These examples can be run without an additional Additive Manufacturing license when you are in DEMO (demonstration) mode. However, the AM Module is not available with the Educational version of Thermo-Calc. Search the help for Available Options with the Additive Manufacturing (AM) Module.

Material Properties

These properties are the same for both AM_01 and AM_02 [2021Gra].

- Inconel 738LC: Ni-15.8 Cr-8.6 Co-2.7 W-3.3 Ti-3.6 Al-1.8 Ta-1.8 Mo-0.04 Fe-0.8 Nb-0.002 Mn-0.1 C Mass percent.
- Database: TCNI12
- The material property was pre-calculated, and stored as a built-in material library of the Additive Manufacturing (AM) Module.

Model Configuration

The transient model solves for the heat equation in the entire 3D domain, including the melt pool, and is therefore, computationally expensive to solve. The fluid flow inside the melt pool due to the Marangoni effect is not included in this example. The double ellipsoidal, or the so-called Goldak heat source model, is used to predict melt pool size and temperature distribution during single track scanning. The parameters for the double ellipsoidal heat source are computed using optimization in a steady-state case for the given process parameters (power and scanning speed) and the melt pool size reported in the paper by Grange et al. [2021Gra]. The resulting parameters are shown in [Figure 78](#).

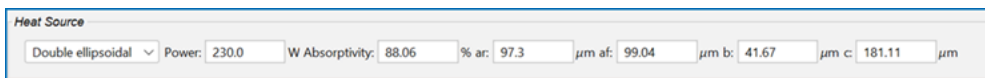

Parameter	Value
Heat Source Model	Double ellipsoidal
Power	230.0 W
Absorptivity	88.06 %
ar	97.3
μm a	99.04
μm b	41.67
μm c	181.11

Figure 78: Optimized heat source parameters entered on the AM Calculator for the experiment given in Grange et al. [2021Gra] with power = 230 W and scanning speed = 960 mm/s.

The geometry for a transient simulation, as given in the paper by Grange et al. [2021Gra], is shown in [Figure 79](#). The base plate is 2 mm in length, 0.5 mm in width, and with a thickness of 0.95 mm. A layer of powder with a thickness of 55 μm is deposited on the solid substrate. The powder layer, however, has the same material properties as the solid substrate. The laser beam with a power of 230 W develops linear scanning with constant velocity 960 mm/s. The trajectory evolves from initial position (x, y) = (0.25, 0.25) mm to final position (1.75, 0.25) mm on the top surface.

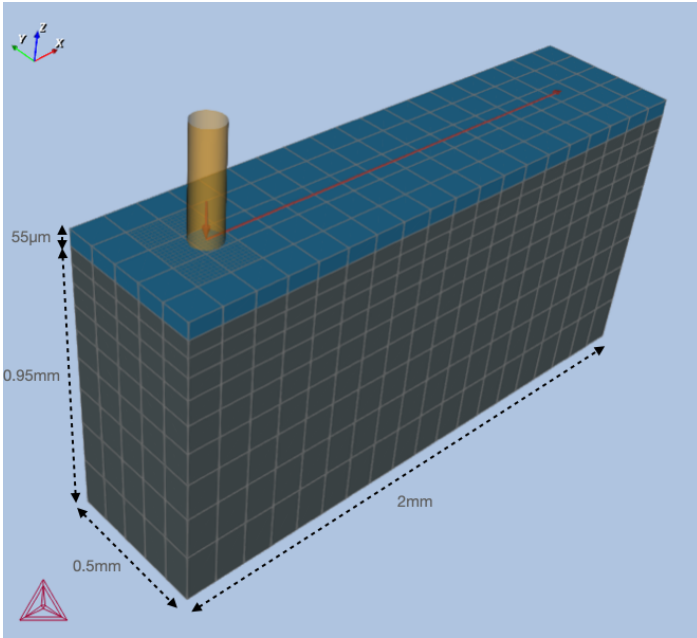

Figure 79: The geometry used for the Additive Manufacturing (AM) Module examples AM_01 and AM_02.

Two probes monitor the temporal evolution of temperature at positions shown in Figure 80. The results can be presented by tabulated data or as 2D graph plots.

Probe Positions								
<input type="checkbox"/>	<input checked="" type="checkbox"/>	x: 0.5	mm	y: 0.25	mm	z: 1.005	mm	Pick coordinate
<input checked="" type="checkbox"/>	<input type="checkbox"/>	x: 0.5	mm	y: 0.29	mm	z: 1.005	mm	Pick coordinate

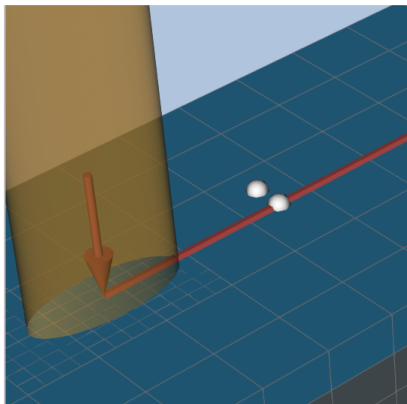

Figure 80: Probe positions for Probes P1 and P2, where P1 is placed exactly on the scanning track while P2 is placed at a distance of 0.04 mm from the track, as shown in a close up of the probes on the Visualizations window.

Visualizations

Open the example project file to review the node setup on the **Project** window and the associated settings on the **Configuration** window for each node. For some types of projects, you can also adjust settings on the **Plot Renderer Configuration** window to preview results before performing the simulation. Click **Perform Tree** to generate plots and tables to see the results on the **Visualizations** window.

There is a variety of information shown in the **Visualizations** window that can be viewed during configuration and after performing the calculation(s).

- **Geometry:** View the geometry and adjust parameters visually by changing inputs on the Configuration window.
- Melt pool and other dynamically changing features can also be visualized and changed.
- **Plot results:** After completing the set up and performing the calculation, to view the matching name of the node on tab(s) in the **Visualizations** window, click a **Plot Renderer** node in the **Project** window or click the tabs individually in the **Visualizations** window.

With the example open and after it is run, the following is a summary of what is visible on the **Visualizations** window.

The figure below shows the surface plot of temperature distribution after the single track scanning is completed. The temperature profile is qualitatively similar to the one in example AM_01, however the maximum temperature is slightly lower in example AM_02. This could be due to selection of a coarse mesh in both examples which sometimes could affect the maximum temperature.

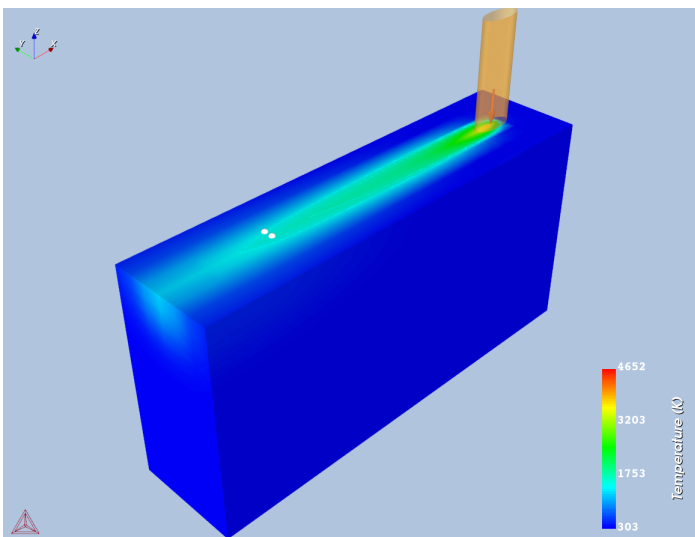

Figure 81: Surface plot of temperature distribution after the single track scan is completed. Probes P1 and P2 can also be seen on the top surface.

The melt pool dimensions for AM_02 are given in the following table, which are very similar to the melt pool dimensions obtained in example AM_01.

Melt Pool Dimension	Size (mm)
Width	0.127
Depth	0.129
Length	1.12

A qualitative comparison between AM_01 and AM_02 can also be made by looking at probe plots. The probe plot for AM_02 is given in Figure 82.

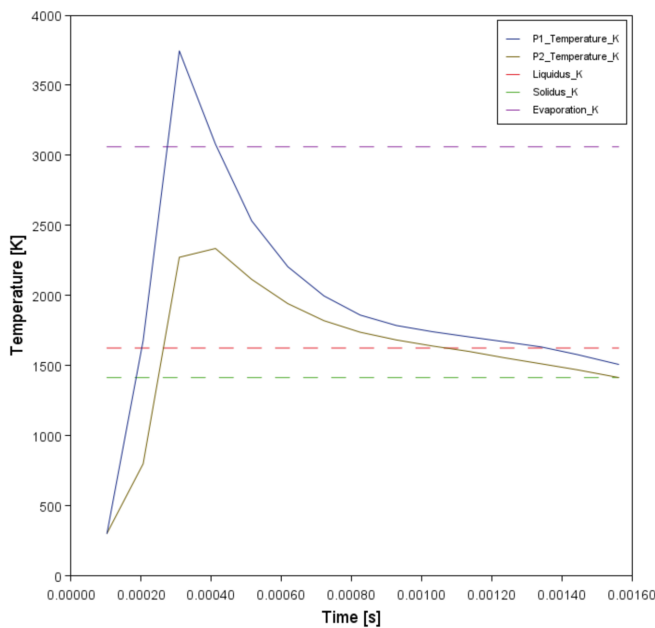

Figure 82: 2D probe plot showing temperature evolution as a function of time at probes P1 and P2.

Despite the fact that maximum temperature is higher in AM_01, the temperature profile in the tail of the melt pool and close to the melt pool is very similar. This can also be concluded by comparing plot over lines for the two examples, where the plot over line for AM_02 is given in Figure 83.

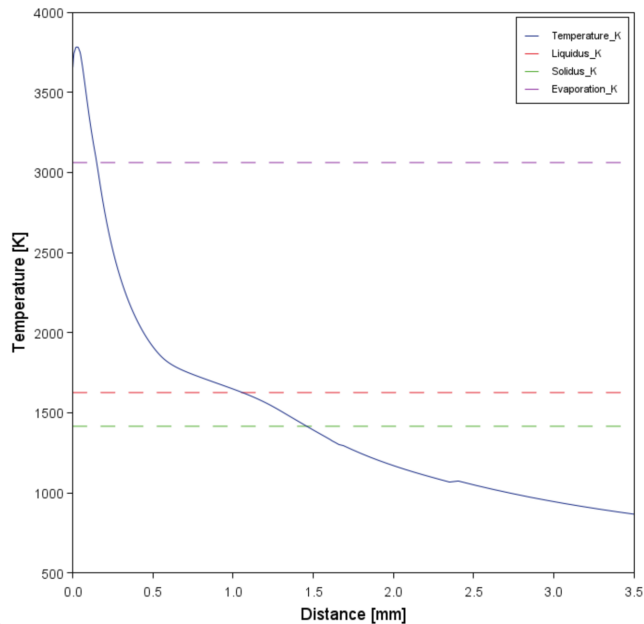

Figure 83: 2D plot over line showing temperature in the tail of the melt pool as a function of distance plotted along the scanning track.

Reference

[2021Gra] D. Grange, A. Queva, G. Guillemot, M. Bellet, J.-D. Bartout, C. Colin, Effect of processing parameters during the laser beam melting of Inconel 738: Comparison between simulated and experimental melt pool shape. J. Mater. Process. Technol. 289, 116897 (2021).

Other Resources



Read more about the [Additive Manufacturing \(AM\) Module](#) on our website including the details about database compatibility or to watch an [introductory webinar](#). You can also use the [Getting Started Guide](#) to learn about the key features available.



Many of our Graphical Mode examples have video tutorials, which you can access in a variety of ways. When in Thermo-Calc, from the menu select **Help** → **Video Tutorials**, or from the main My Project window, click **Video Tutorials**. Alternately, you can go to the [website](#) or our [YouTube channel](#).

AM_03: Steady-state Simulations

The following example is part of a series showing some of the features of the Additive Manufacturing (AM) Module and the **AM Calculator**.

In this example steady-state simulations are performed for IN625 with different conditions i.e.

- i. without fluid flow in the melt pool,
- ii. with fluid flow in the melt pool due to Marangoni effect, and
- iii. using separate material properties for powder and fluid flow in the melt pool due to Marangoni effect.

and then the results are compared to demonstrate the effects of fluid flow and separate material properties for the powder on the temperature distribution as well as on the shape of the melt pool.



For the first two simulations, the same material properties are used for both powder and solid substrate.



In steady-state simulations it is assumed that the heat source (laser beam) moves with a uniform speed relative to the base plate. In this case, the model is solved by modifying governing equations to a reference frame attached to a moving heat source. Furthermore, in steady-state mode you can make use of symmetry along the width of the geometry and solve for only half of the domain.

Project File and License Information

- Folder: **Additive Manufacturing**
 - File name: `AM_03_Steady.tcu`
-



A separate license is required to perform calculations with the Additive Manufacturing (AM) Module. Without a license you are in *Demo Mode* where you can, for example, open and view example set ups, run some examples, add templates and nodes to the Project window, adjust some Configuration settings, and preview some functionality on the Visualizations window.



Some examples (AM_01, AM_02, AM_03, and AM_06b) are available to all users. These examples can be run without an additional Additive Manufacturing license when you are in DEMO (demonstration) mode. However, the AM Module is not available with the Educational version of Thermo-Calc. Search the help for Available Options with the Additive Manufacturing (AM) Module.

Visualizations

Open the example project file to review the node setup on the **Project** window and the associated settings on the **Configuration** window for each node. For some types of projects, you can also adjust settings on the **Plot Renderer Configuration** window to preview results before performing the simulation. Click **Perform Tree** to generate plots and tables to see the results on the **Visualizations** window.

There is a variety of information shown in the **Visualizations** window that can be viewed during configuration and after performing the calculation(s).

- **Geometry:** View the geometry and adjust parameters visually by changing inputs on the Configuration window.
- Melt pool and other dynamically changing features can also be visualized and changed.
- **Plot** results: After completing the set up and performing the calculation, to view the matching name of the node on tab(s) in the **Visualizations** window, click a **Plot Renderer** node in the **Project** window or click the tabs individually in the **Visualizations** window.

Results Discussion

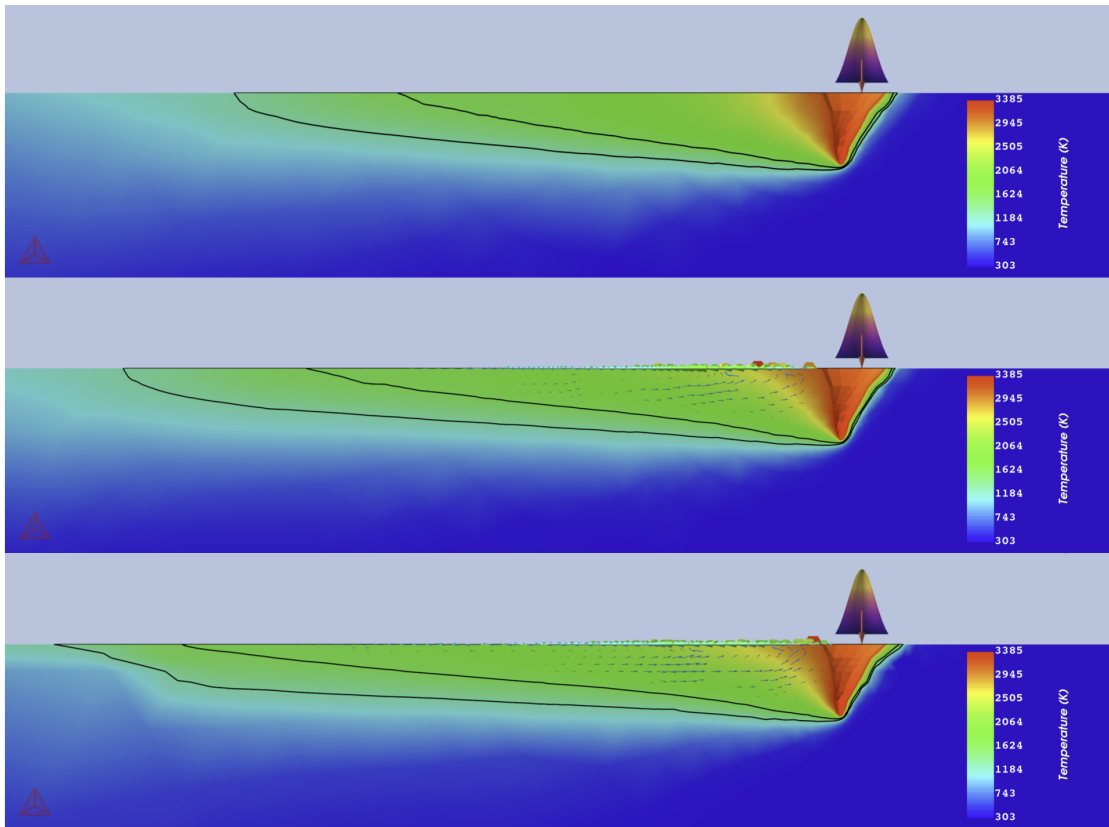

Figure 84: A comparison of the melt pool depth for different simulation conditions; (top) without fluid flow, (middle) with fluid flow in the melt pool and (bottom) with both fluid flow and different material properties for the powder layer. Isocontours show the boundaries of (inner) melt pool and (outer) mushy zone.

The table shows a comparison of the melt pool dimensions for different simulation conditions.

Simulation Set Up	Melt Pool Dimensions (mm)		
	Width	Depth	Length
Without fluid flow	0.115	0.111	0.736
With fluid flow	0.147	0.111	0.869
Separate powder material properties	0.194	0.111	1.064

Figure 84 shows the effect of fluid flow on temperature distribution and size of the melt pool for the given process parameters. A quantitative comparison is also given in the table. It can be seen that with the addition of fluid flow due to gradient in surface tension (Marangoni effect), the melt pool tends to increase

its dimensions in all three directions. This is because the negative gradient in surface tension with respect to the temperature creates an outward flow on the surface of the melt pool which consequently increases the width and length of the melt pool, as shown in Figure 85.

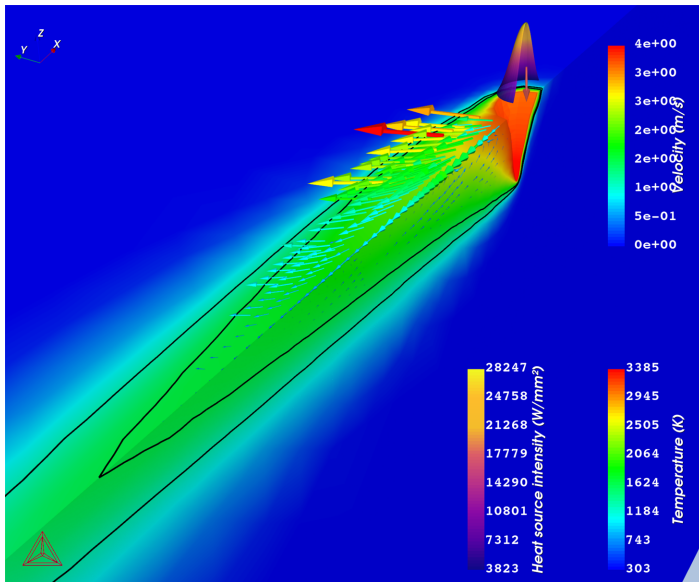

Figure 85: Vectors showing flow field in the melt pool due to gradient in surface tension. The colors of the vectors represent the magnitude of the velocity. Surface colormap shows the temperature distribution.

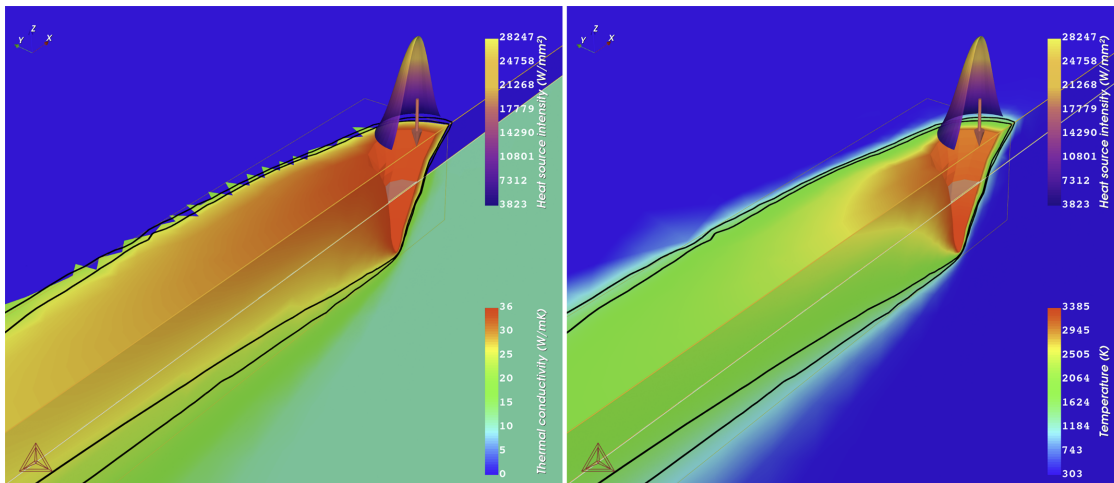

Figure 86: Surface colormap of temperature dependent thermal conductivity showing different values in powder and liquid/solid and (right) the corresponding temperature distribution.

Using separate material properties for powder has a significant effect on both the temperature distribution and the size of the melt pool. This is because a lower thermal diffusivity in the powder makes the temperature to diffuse more towards the length of the melt pool hence causing a significant increase in the

length of the melt pool (shown in Figure 86) as compared to the first two cases. There is also an obvious increase in the width of the melt pool while the depth of the melt pool is almost the same as with the fluid flow. Furthermore, the maximum temperature is also highest in the case with separate material properties.

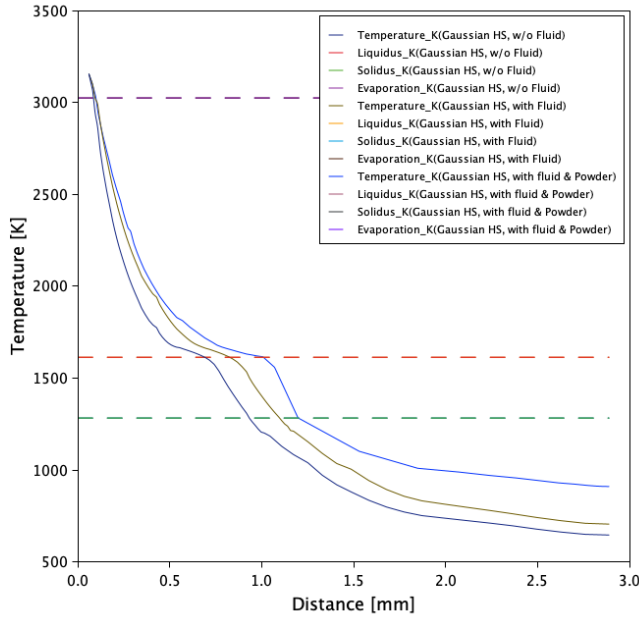

Figure 87: Temperature distribution along the top surface of the melt pool from the heat source position toward the tail. The plot compares three conditions: no fluid flow (solid blue line), fluid flow only (dashed green line), and combined powder and fluid flow (dash-dotted red line).

Other Resources



Read more about the [Additive Manufacturing \(AM\) Module](#) on our website including the details about database compatibility or to watch an [introductory webinar](#). You can also use the [Getting Started Guide](#) to learn about the key features available.



Many of our Graphical Mode examples have video tutorials, which you can access in a variety of ways. When in Thermo-Calc, from the menu select **Help** → **Video Tutorials**, or from the main My Project window, click **Video Tutorials**. Alternately, you can go to the [website](#) or our [YouTube channel](#).

AM_04: Scheil Transient Steady-state

In this example, three different simulations are performed: Steady-state, Transient Single track, and Transient Multilayer. Both Transient Single track and Transient Multilayer use **Transient with heat source from Steady-state** model to compute time-dependent temperature distribution in the given geometry. The primary difference between this example and the previous examples (AM_01 to AM_03) is that, in this case, the material properties data is retrieved from the Scheil Calculator whereas in the previous examples the material properties are taken from the preinstalled material library. Furthermore, this example simulates scanning of two layers of powder where the second layer is spread on the top of the first layer when scanning of the first layer is completed.

Project File and License Information

- Folder: **Additive Manufacturing**
- File name: AM_04_Scheil_TransientSS.tcu



Material chosen for this example is Ti-6Al-4V. To run this example requires both version TCTI5.0 and newer of the TCS Ti/TiAl-based Alloys Database (TCTI) in addition to a license for the Additive Manufacturing (AM) Module. Some portions of this example are also covered in the [Getting Started Guide](#) on our website.

Visualizations

Open the example project file to review the node setup on the **Project** window and the associated settings on the **Configuration** window for each node. For some types of projects, you can also adjust settings on the **Plot Renderer Configuration** window to preview results before performing the simulation. Click **Perform Tree** to generate plots and tables to see the results on the **Visualizations** window.



When you run (Perform) this example, it takes at least 30 minutes for the calculations to complete.

There is a variety of information shown in the **Visualizations** window that can be viewed during configuration and after performing the calculation(s).

- **Geometry:** View the geometry and adjust parameters visually by changing inputs on the Configuration window.
- Melt pool and other dynamically changing features can also be visualized and changed.
- **Plot results:** After completing the set up and performing the calculation, to view the matching name of the node on tab(s) in the **Visualizations** window, click a **Plot Renderer** node in the **Project** window or click the tabs individually in the **Visualizations** window.

Steady-state

The Steady-state calculator of this example computes temperature distribution in a steady state for the power of 100 W and scanning speed of 600 mm/s. The beam radius in this example is taken as 100 μm . For the geometry, the steady-state model only needs the height of the solid substrate as the input, which is taken as 2.0 mm. The solid substrate is covered with a powder layer of thickness 55 μm . This example also takes into account the effect of fluid flow due to Marangoni forces inside the melt pool.

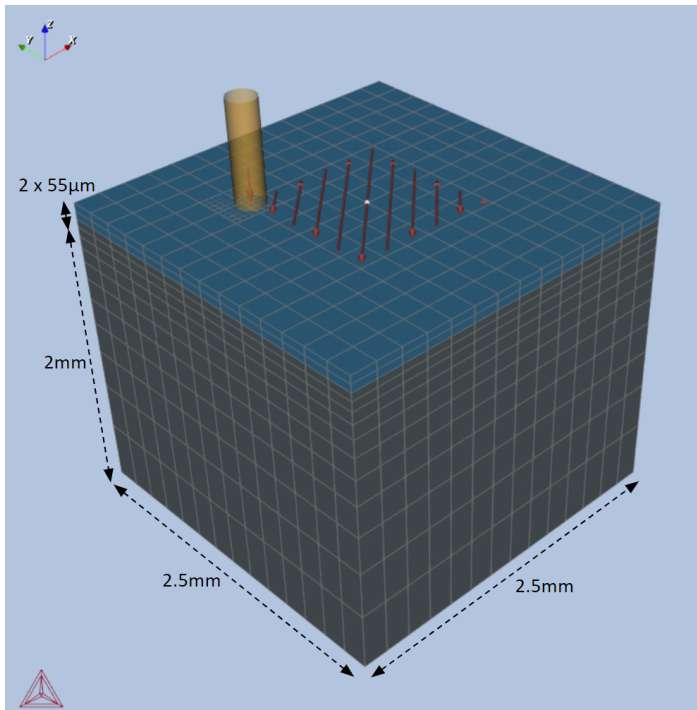

Figure 88: Geometry definition for Transient Multilayer. The scanning strategy shows the scanning pattern on the top most layer.

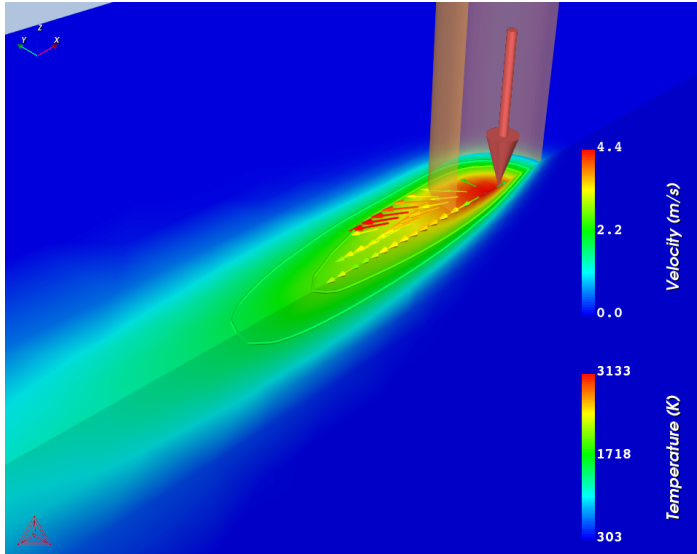

Figure 89: Temperature distribution around the melt pool and mushy zone for the Steady-state case. Velocity vectors representing the fluid flow inside the melt pool can also be seen.

Transient Single Track

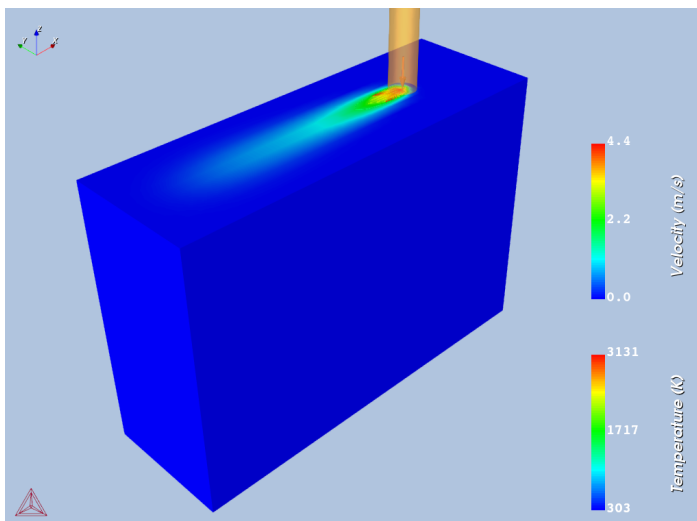

Figure 90: 3D Surface colormap showing temperature distribution at the end of single track transient simulation. The velocity vectors around the heat source show the direction of fluid flow in the melt pool.

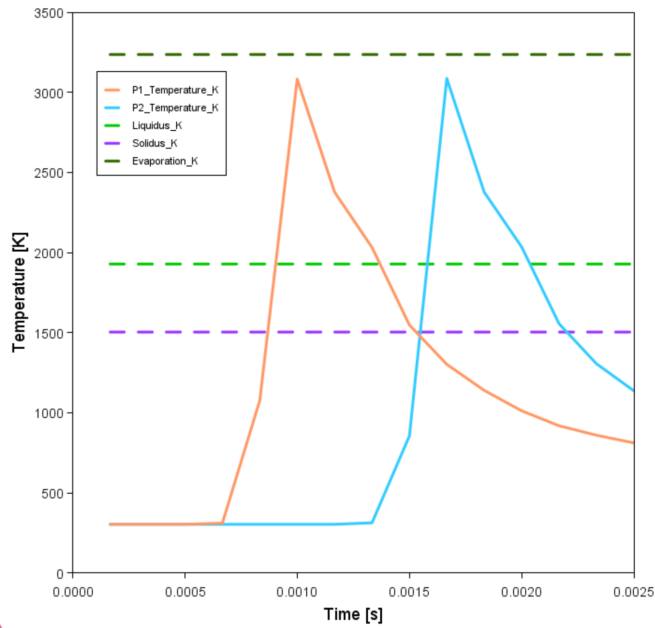

Figure 91: 2D Plot showing temperature as a function of time from Probe 1 (orange) and Probe 2 (blue) after the single track scan is completed.

Transient Multilayer

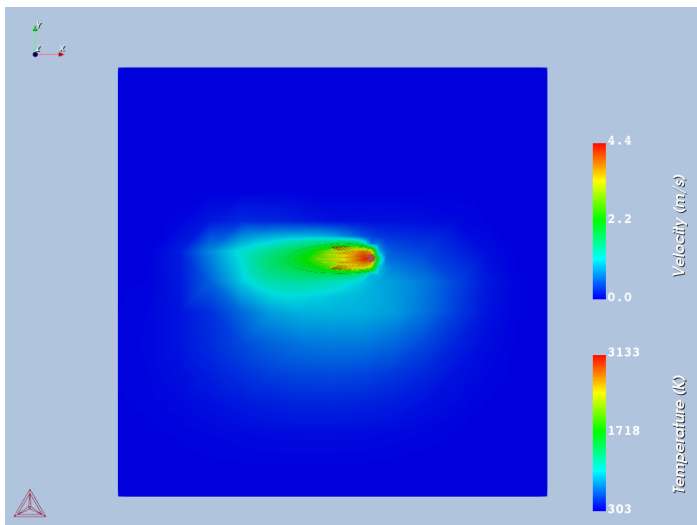

Figure 92: Temperature distribution on the top surface of the workpiece during scanning of the first layer.

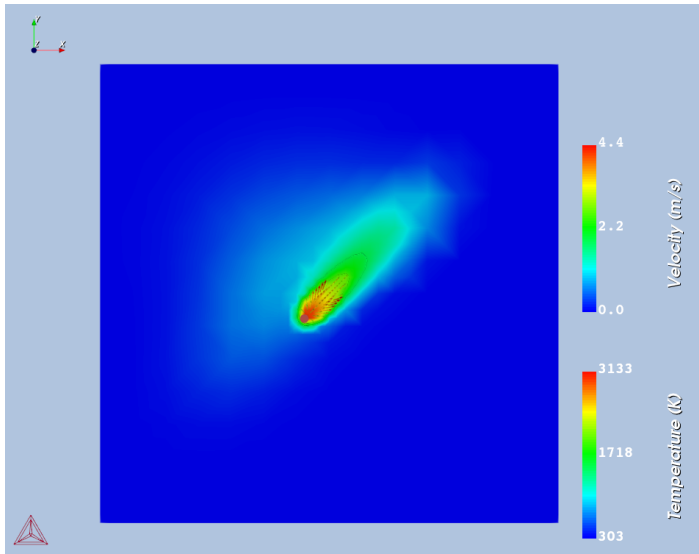

Figure 93: Temperature distribution on the top surface of the workpiece during scanning of the second layer.

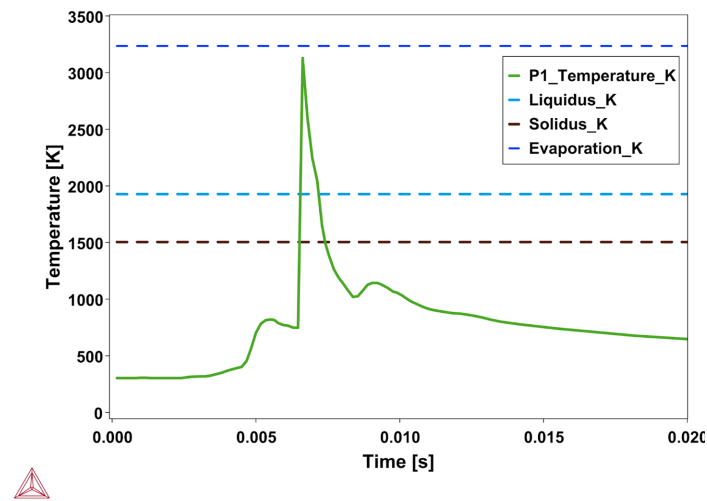

Figure 94: 2D Plot showing temperature as a function of time from Probe 1 after scanning the first layer.

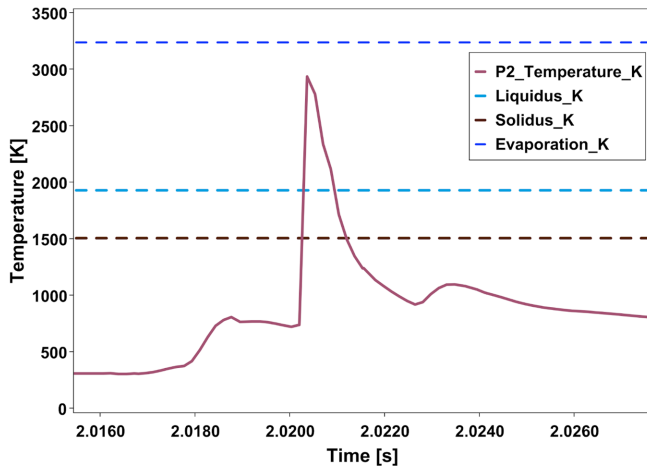

Figure 95: 2D Plot showing temperature as a function of time from Probe 2 after scanning the second layer.

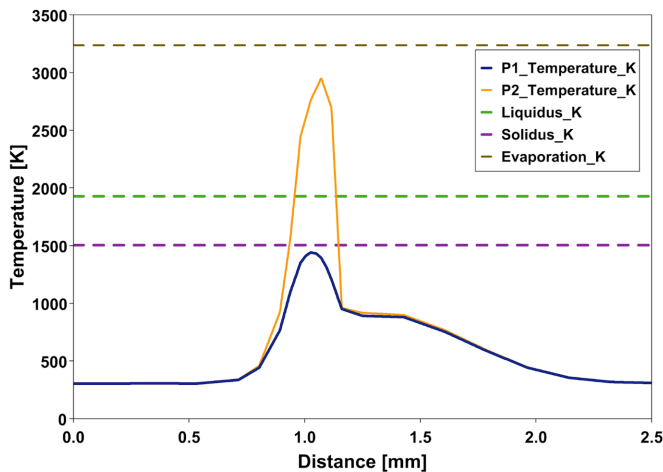

Figure 96: 2D Plot Over Line showing temperature profiles plotted along the lines, parallel to the width of the geometry placed on the top of the first layer (P1) and the second layer (P2).

Other Resources



Read more about the [Additive Manufacturing \(AM\) Module](#) on our website including the details about database compatibility or to watch an [introductory webinar](#). You can also use the [Getting Started Guide](#) to learn about the key features available.



Many of our Graphical Mode examples have video tutorials, which you can access in a variety of ways. When in Thermo-Calc, from the menu select **Help → Video Tutorials**, or from the main My Project window, click **Video Tutorials**. Alternately, you can go to the [website](#) or our [YouTube channel](#).

AM_05: Using AM Calculator Probe Data with the Diffusion Module (DICTRA)

The microstructure of a hot-work tool steel additively manufactured using laser powder-bed fusion (L-PBF) is studied in detail by microstructure characterization and computational thermodynamics and kinetics by C.-Y. Chou et al. [2021Cho].

This example demonstrates the application of adding probes to an AM Calculator and then using this data via the Thermal Profile that is set up on a connected Diffusion Calculator. The example also uses a Scheil Calculator to collect some materials data that is then further used with the AM Calculator prior to using the probe data generated by the AM Calculator.

Project File and License Information

- Folder: **Additive Manufacturing**
- File name: `AM_05_AM_Probe_to_Diffusion.tcu`



A separate license is required to perform calculations with the Additive Manufacturing (AM) Module. This example also requires a license for the Diffusion Module (DICTRA), plus additional database licenses for the TCS Steel and Fe-alloys Database (TCFE) (TCFE13 and newer), and the TCS Steels/Fe-Alloys Mobility Database (MOBFE) (MOBFE8 and newer).

Background

According to the thermodynamics of this steel, δ -ferrite is the solid phase stable at the highest temperature and would be the first solid phase to form during solidification from a thermodynamic point of view, see [Figure 97](#).

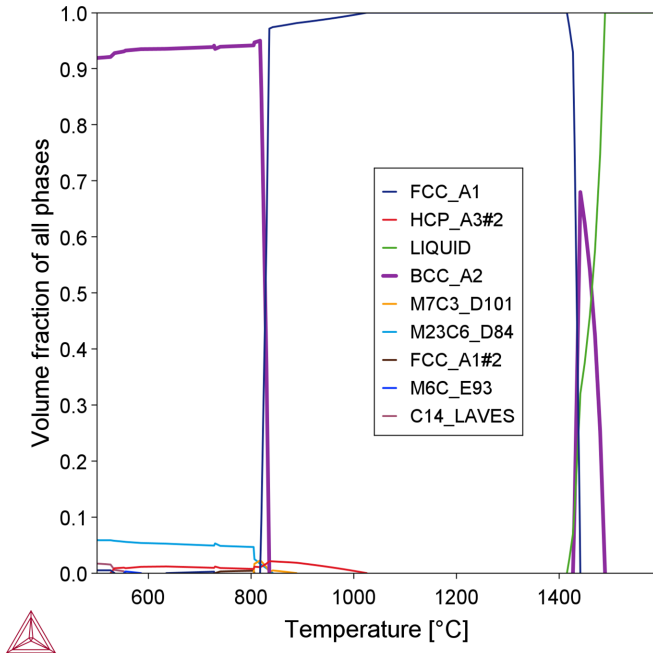

Figure 97: Equilibrium property diagram calculated in Thermo-Calc of the tool steel showing δ -ferrite would be the first solid phase to form during solidification according to equilibrium.

However, the high solidification and cooling rates during the L-PBF process lead to suppression of δ -ferrite and instead solidification of an austenite phase directly containing a cellular substructure where the alloying elements have segregated to the inter-cellular regions.

The microsegregation can be predicted by reducing the complex solidification behavior to a diffusion problem in one dimension enabling comparisons with the measured segregation profiles quantified at a nanometer scale.

Configuration and Calculation Set Up

For all calculations, the simplified composition Fe-0.35C-4.93Cr-0.45Mn-2.24Mo-0.25Si-0.54V (mass%) was used with δ -ferrite suspended on the System Definer.

The **Additive Manufacturing** template was used to first add the **System Definer**, **Scheil Calculator**, **AM Calculator**, and **Plot Renderer** to the **Project** window tree. Additionally, a **Diffusion Calculator** was added as a successor to the AM Calculator in order to automatically import the time-temperature profile from the AM simulation into the diffusion simulation. See [Figure 98](#) (or refer to the example if you have it open) to see the layout.

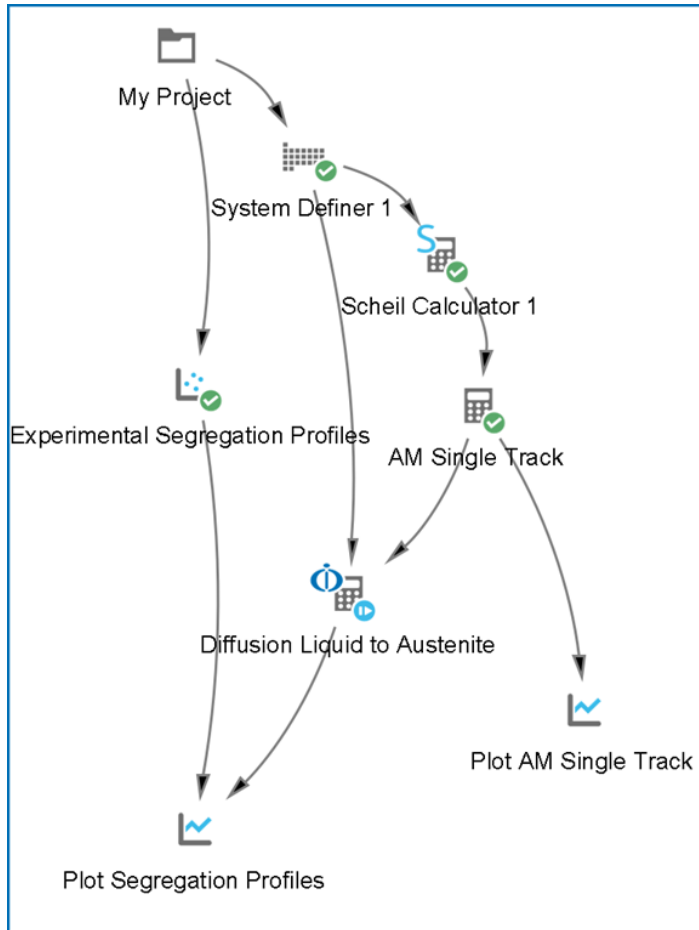
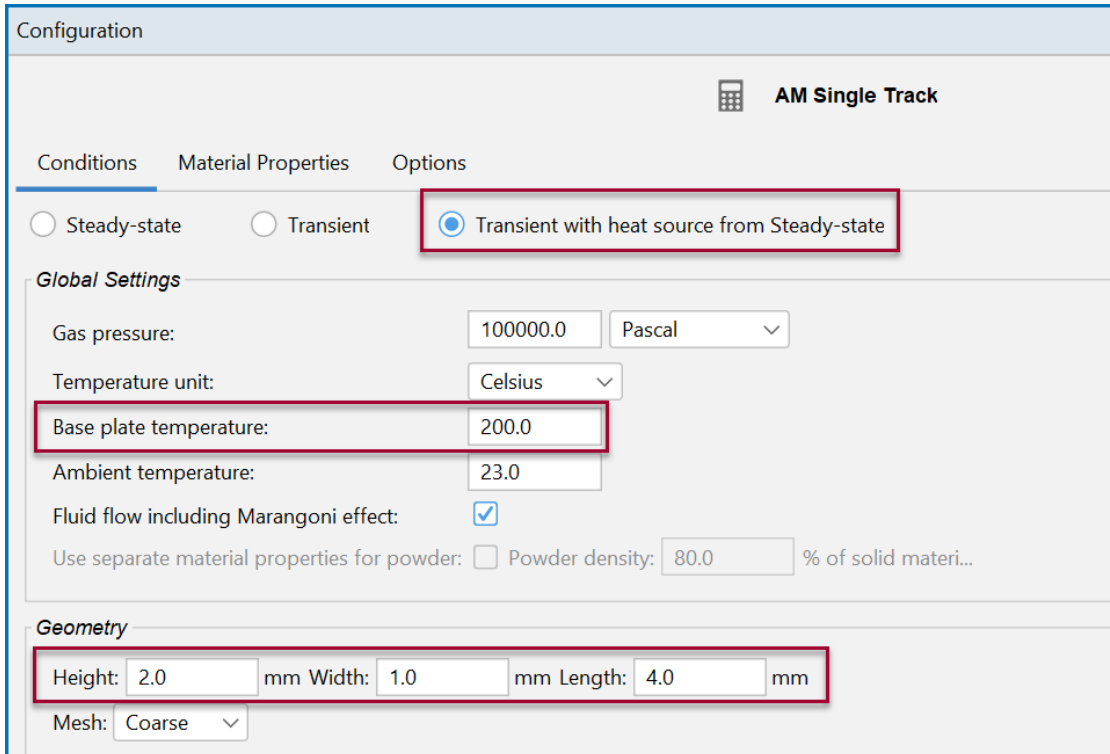



Figure 98: Project tree of the example containing activities from the default Additive Manufacturing template with additional Diffusion Calculator and Experimental File Reader nodes added, where the segregation profiles datasets are pulled from the Experimental File Reader.

On the **AM Calculator Configuration** window, the calculation type **Transient with heat source from Steady-state** is selected with a single track scan pattern and a **Geometry** of 2 mm x 1 mm x 4 mm (height x width x length). The **Base plate temperature** is set to 200 °C.



Configuration

 **AM Single Track**

Conditions Material Properties Options

Steady-state Transient **Transient with heat source from Steady-state**

Global Settings

Gas pressure: 100000.0 Pascal

Temperature unit: Celsius

Base plate temperature: 200.0

Ambient temperature: 23.0

Fluid flow including Marangoni effect:

Use separate material properties for powder: Powder density: 80.0 % of solid materi...

Geometry

Height: 2.0 mm Width: 1.0 mm Length: 4.0 mm

Mesh: Coarse

Additional settings are then made on the **Configuration** window as follows.

The **Double ellipsoidal** volume heat source was previously assessed as a function of linear energy density for a similar material and directly applied to the experimental conditions of a volumetric energy density of 80 J/mm³. The laser **Power** is entered at 260 W, **Scanning speed** at 900 mm/s, and powder **Layer thickness** 30 μm. Below is a snapshot of the settings.

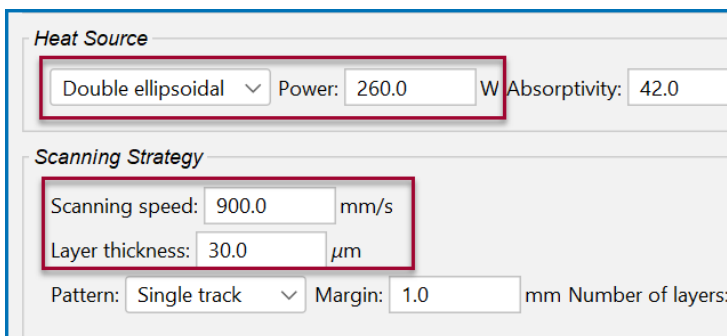

Heat Source

Double ellipsoidal Power: 260.0 W Absorptivity: 42.0

Scanning Strategy

Scanning speed: 900.0 mm/s

Layer thickness: 30.0 μm

Pattern: Single track Margin: 1.0 mm Number of layers:

A probe was then added in the center of the scan track at a distance of 1.3 mm from the edge. The **Probe Positions** can either be entered directly on the Configuration window or click the **Pick coordinate** button and then click on the geometry in the **Visualizations** window to directly choose the probe point (or points if there is more than one probe added).

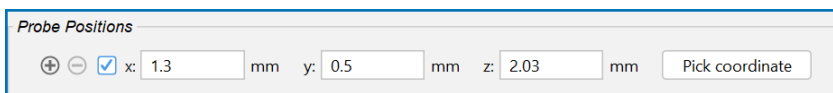

Probe Positions

x: 1.3 mm y: 0.5 mm z: 2.03 mm

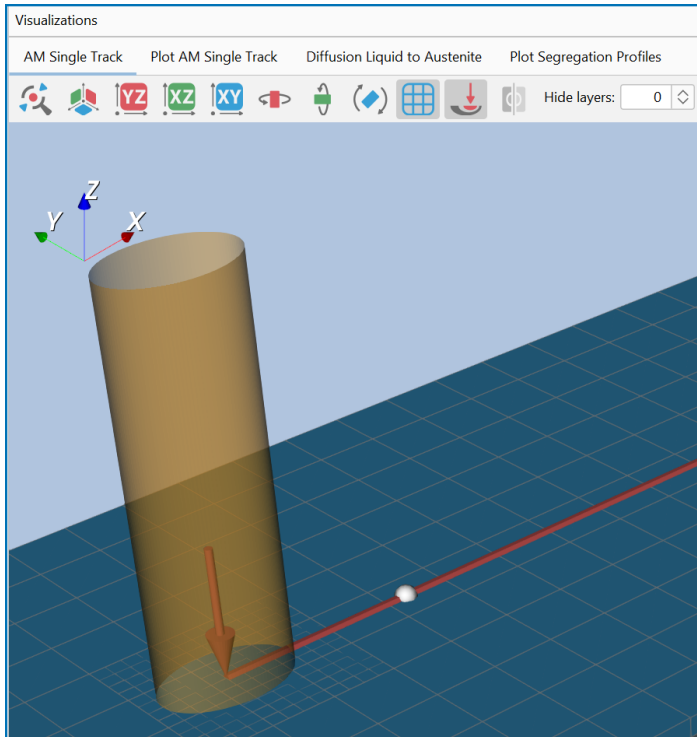

Figure 99: Close up of the probe point added to the geometry for the single track AM simulation.

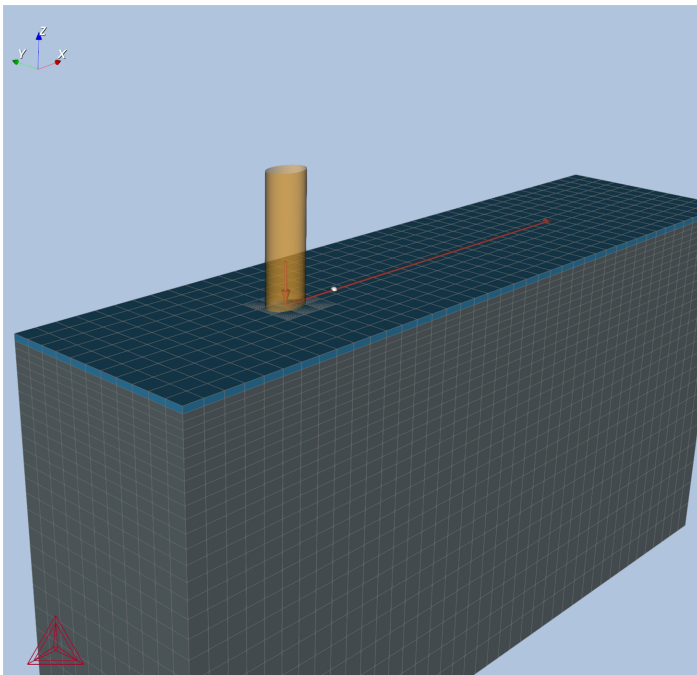
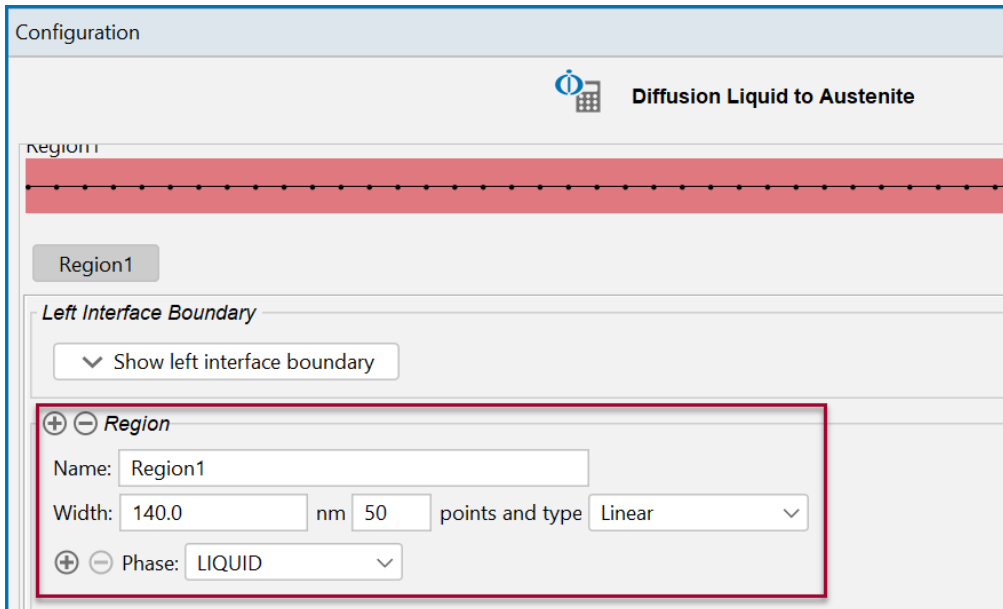

Figure 100: The full geometry set up for the single track AM simulation with a probe point added to the middle of the scan. Open the example to better see the set up and to try working within the window.

Diffusion Calculations

For the Diffusion Module (DICTRA) solidification calculations using the **Diffusion Calculator**, only the liquid to austenite (FCC) transformation was simulated. On the **Diffusion Calculator Configuration** window, a **Region** of 140 nm with liquid and FCC allowed to form at the right boundary is set.



In the *Thermal Profile* section, the time temperature from the probe was selected between a **Start time** of 5.0E-4 and **Simulation time** of 8.5E-4 s in order to only simulate the solidification, which can be viewed on the **Visualizations** window as in [Figure 101](#). Note that the probes need to be added and then run in the AM Calculator to make this data available in for this part of the calculation.

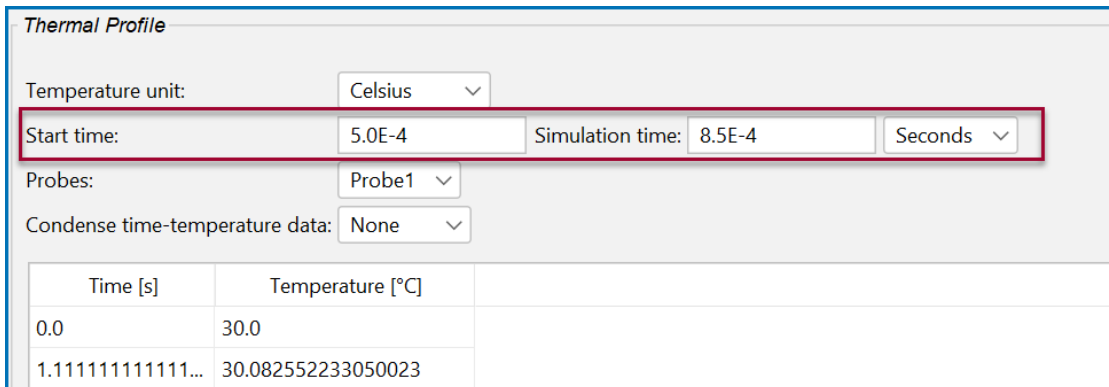

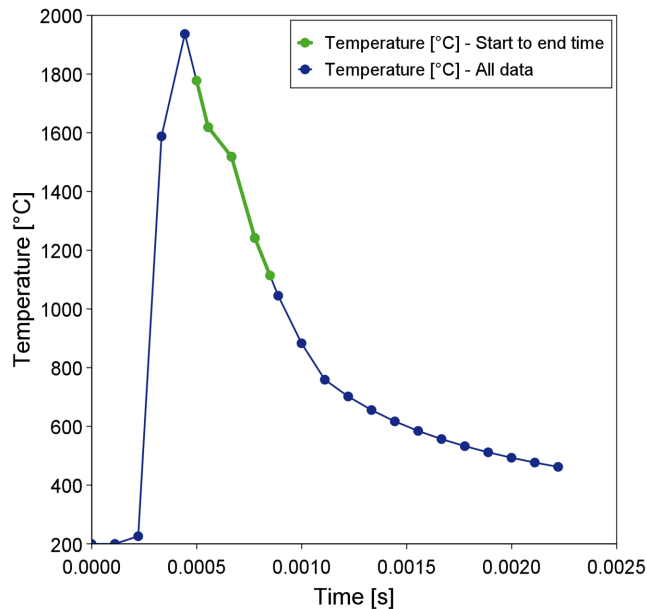

Figure 101: Time temperature profile of the probe in the AM simulation. The green curve show the part of the profile used during the diffusion simulation with the Diffusion Calculator.

The calculated segregation profiles are finally compared with the STEM-EDS line scans as shown in Figure 102.

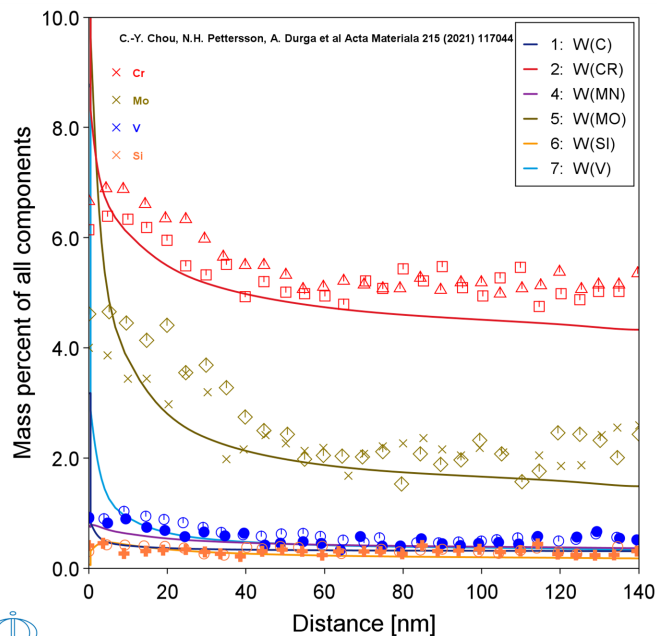

Figure 102: The simulated segregation profile with overlaid experimental STEM-EDS line scans from C.-Y. Chou et al. [2021Cho].

Visualizations

Open the example project file to review the node setup on the **Project** window and the associated settings on the **Configuration** window for each node. For some types of projects, you can also adjust settings on the **Plot Renderer Configuration** window to preview results before performing the simulation. Click **Perform Tree** to generate plots and tables to see the results on the **Visualizations** window.



When you run (Perform) this example, it can take over three hours to complete the calculations.

There is a variety of information shown in the **Visualizations** window that can be viewed during configuration and after performing the calculation(s). This example highlights some of these capabilities:

- **Probes:** Probes are added to the AM Calculator during the set up either by entering coordinates or directly adding these to the geometry. See [Figure 99](#) and [Figure 100](#) for example.
- **Thermal Profile:** The Diffusion Calculator Thermal Profile settings automatically include the probe data and you can visualize to help you continue the simulation. See [Figure 101](#).
- **Plot results:** After completing the set up and performing the calculation, to view the matching name of the node on tab(s) in the **Visualizations** window, click a **Plot Renderer** node in the **Project** window or click the tabs individually in the **Visualizations** window. See [Figure 102](#).

Reference

[2021Cho] C.-Y. Chou, N. H. Pettersson, A. Durga, F. Zhang, C. Oikonomou, A. Borgenstam, J. Odqvist, G. Lindwall, Influence of solidification structure on austenite to martensite transformation in additively manufactured hot-work tool steels. *Acta Mater.* 215, 117044 (2021).

Other Resources



Read more about the [Additive Manufacturing \(AM\) Module](#) on our website including the details about database compatibility or to watch an [introductory webinar](#). You can also use the [Getting Started Guide](#) to learn about the key features available.



Many of our Graphical Mode examples have video tutorials, which you can access in a variety of ways. When in Thermo-Calc, from the menu select **Help → Video Tutorials**, or from the main My Project window, click **Video Tutorials**. Alternately, you can go to the [website](#) or our [YouTube channel](#).

AM_06a: Calibrating a Heat Source for a 316L Steel

This example demonstrates the calibration of the heat source using the Gaussian as well as Double ellipsoidal heat sources. In this example, experimental data is taken from Hu. et al. [2019Hu] where the authors performed single-track experiments using the selective laser melting (SLM) process on 316L stainless steel for varying processing conditions. The power ranges from 50 W to 100 W while the scanning speed varies from 400 mm/s to 2800 mm/s. The data imported from [2019Hu], consisting of 21 experimental points, is saved in the project file.



Also see the companion example, "AM_06b: Using the Calibrated Heat Source for a 316L Steel" on page 154.

Project File and License Information

- Folder: **Additive Manufacturing**
- File name: `AM_06a_Calibrate_Heat_Sources_316L.tcu`



An Additive Manufacturing Module license is needed to run AM_06a.



Some examples (AM_01, AM_02, AM_03, and AM_06b) are available to all users. These examples can be run without an additional Additive Manufacturing license when you are in DEMO (demonstration) mode. However, the AM Module is not available with the Educational version of Thermo-Calc. Search the help for Available Options with the Additive Manufacturing (AM) Module.

Material Properties

- SS316L: Fe-17.0Cr-12.0Ni-2.5Mo-0.03C Mass percent
- Database: TCFE13
- The material properties are precalculated, and stored as a built-in material library with the Additive Manufacturing (AM) Module.

AM Calculator Configuration Settings

The AM_06a example contains two AM Calculators, which are renamed to **AM Calibration Gaussian** and **AM Calibration Double Ellipsoidal**.

- **AM Calibration Gaussian** uses a **Gaussian Heat Source** with the **keyhole model**.
- **AM Calibration Double Ellipsoidal** uses a **Double ellipsoidal Heat Source**.
- The heat source parameters for both heat sources are calibrated for the given experimental data.
- For both AM Calculators, the **Base plate temperature** and the **Ambient temperature** use a value of 353 K and the **Layer thickness** is 10 μm . The rest of the Configuration settings keep the original defaults.

For **AM Calibration Gaussian**, all of the 21 experimental points that are imported to the *Experiment Data* table are selected to be used in the calibration. This is because, for the Gaussian heat source with the keyhole model, one wants to obtain a single constant value for beam radius as well as absorptivity to correctly predict the melt pool size for a range of power and scanning speed. It is also in order to obtain the best possible value it is good to include as many experiments as you can to calibrate the heat source parameters.

For this AM Calculator, other settings include:

- **Constant (calibrated)**, which means the absorptivity is not a function of temperature or angle, and a constant value is calibrated for each experiment.
- The **Beam radius** is set to **Calibrated**, which means that both beam radius and absorptivity are calibrated.
- **Calibrate for** is set to **Width and depth**, which means that the experimental values for both width and depth are used for calibration.

For **AM Calibration Double Ellipsoidal**, only five (5) experiment points are selected to perform the calibration. Two experiments are selected from the lower energy density, two from the higher energy density, and then one experiment is selected in the middle region of the two extremes.

Visualizations

Open the example project file to review the node setup on the **Project** window and the associated settings on the **Configuration** window for each node. For some types of projects, you can also adjust settings on the **Plot Renderer Configuration** window to preview results before performing the simulation. Click **Perform Tree** to generate plots and tables to see the results on the **Visualizations** window.



When you run (Perform) this example, it can take about an hour to complete the calculations.

There is a variety of information shown in the **Visualizations** window that can be viewed during configuration and after performing the calculation(s).

Calibrated Functions

For **AM Calibration Gaussian**, a comparison of the melt pool dimensions from the experiments and calibration simulation is shown in [Figure 103](#).

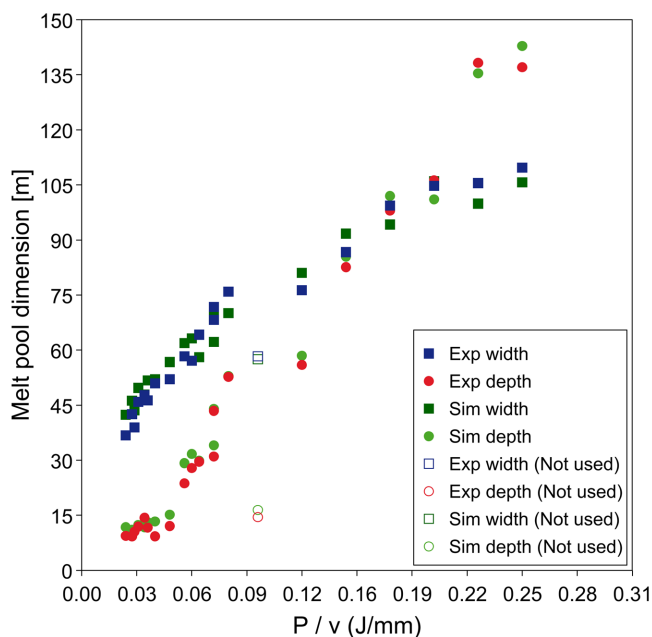

Figure 103: A comparison of melt pool dimension for Gaussian heat source calibration. The "Not used" points shown in the legend are because a checkbox is not selected in the 'Use' column for row 10 on the Plot Renderer Configuration window.

The resulting calibrated heat source parameters for **AM Calibration Gaussian**, are shown in [Figure 104](#).

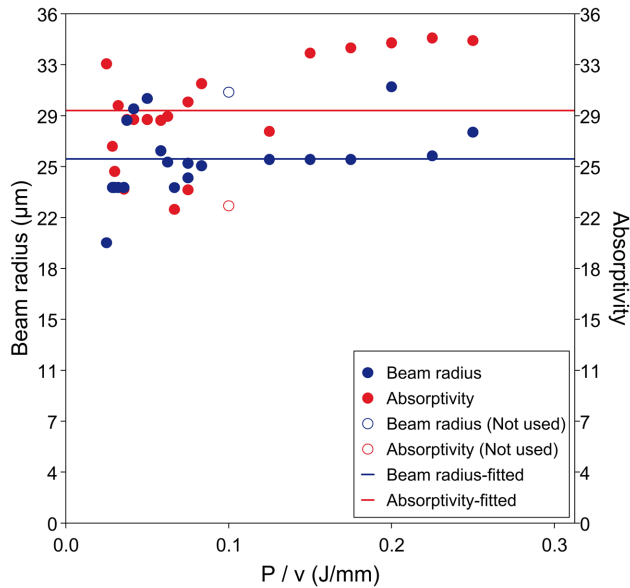

Figure 104: Calibrated heat source parameters for Gaussian heat source calibration.

In order to obtain the expressions for **Absorptivity** and **Beam radius**, one of the experiments (*Experiment # 10*) is not included. This is because *Experiment # 10* is an outlier and you can see that the values for *Exp width* and *Exp depth* (hollow square) then the *Sim width* and *Sim depth* (hollow circle) are excluded in Figure 103.

For both **Absorptivity** and **Beam radius** the **Constant function of P/v** is chosen to be saved as a calibrated heat source. Absorptivity of the material at the printing conditions is usually unknown in these experiments which is why it is regarded as a fitting parameter. Beam radius, on the other hand, is most often known, but does not match the definition of beam radius in the Gaussian heat source model used in the simulation, which is why a different value is obtained as compared to the one used in the experiment.

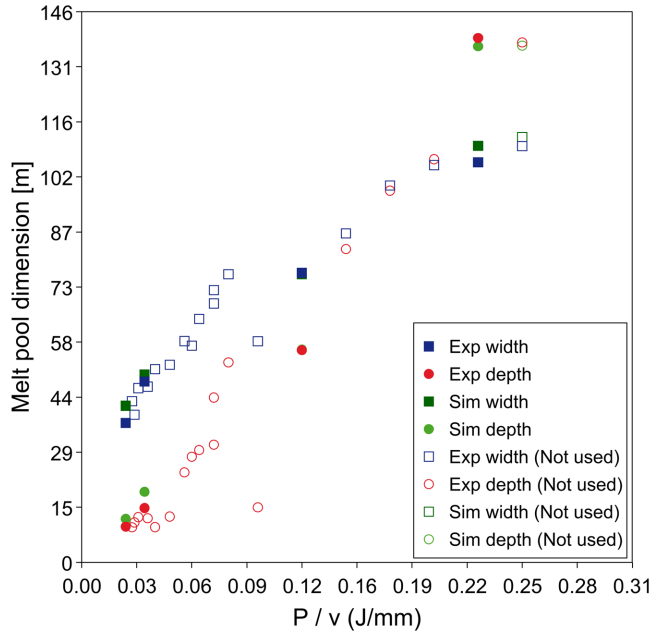

Figure 105: A comparison of melt pool dimension for double ellipsoidal heat source calibration.

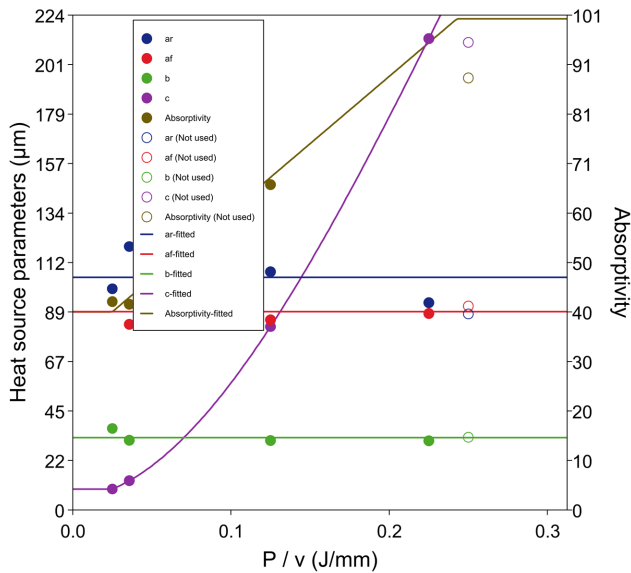

Figure 106: Calibrated heat source parameters for double ellipsoidal heat source calibration.

While selecting the functions for heat source parameters for double ellipsoidal, it was seen that **ar**, **af**, and **b** remained almost unchanged for all the experiments. Therefore the **Constant function of P/v** for **ar**, **af**,

a and **b** is used. For **Absorptivity**, a **Linear function of P/v** gave the best R2 value while for **c** a **Cubic function of P/v** gave the best R2 value. One of the experiments (experiment # 21) was excluded (i.e. the checkbox is deselected) to get a suitable curve for all functions.

Reference

[2019Hu] Z. Hu, B. Nagarajan, X. Song, R. Huang, W. Zhai, J. Wei, Formation of SS316L Single Tracks in Micro Selective Laser Melting: Surface, Geometry, and Defects. Adv. Mater. Sci. Eng. 2019, Article ID 9451406, 1–9 (2019).

Other Resources



Read more about the [Additive Manufacturing \(AM\) Module](#) on our website including the details about database compatibility or to watch an [introductory webinar](#). You can also use the [Getting Started Guide](#) to learn about the key features available.



Many of our Graphical Mode examples have video tutorials, which you can access in a variety of ways. When in Thermo-Calc, from the menu select **Help → Video Tutorials**, or from the main My Project window, click **Video Tutorials**. Alternately, you can go to the [website](#) or our [YouTube channel](#).

AM_06b: Using the Calibrated Heat Source for a 316L Steel

This example demonstrates the use of the two calibrated heat sources that are saved in the example AM_06a. One heat source is of the Gaussian type while the other heat source is Double ellipsoidal. For both heat sources, expressions are saved as a function of energy density (P/v) for all heat source parameters as well as the absorptivity. The example consists of four AM Calculators, two of which use a Gaussian heat source while the other two use a Double ellipsoidal heat source, and where the processing conditions for all four AM Calculators are taken from Hu et al [2019Hu].



"AM_06a: Calibrating a Heat Source for a 316L Steel" on page 148

Project File and License Information

- Folder: **Additive Manufacturing**
- File name: AM_06b_Use_Calibrated_Heat_Sources_316L.tcu



Other than an Additive Manufacturing (AM) Module license, this example does not require an additional license to run it, although its companion example, AM_06a, does.

Material Properties

- SS316L: Fe-17.0Cr-12.0Ni-2.5Mo-0.03C Mass percent
- Database: TCFE13
- The material properties are precalculated, and stored as a built-in material library with the Additive Manufacturing (AM) Module.

Configuration and Calculation Set Up

There are four AM Calculators where all the calculators use the **Steady-state** simulation type and the **Single point Calculation Type**. The purpose of this example is to use the saved heat sources from AM_06a and then validate the results by comparing the melt pool size from the simulations with the experimental melt pool dimensions as given in Hu et. al [2019Hu].

The saved heat sources are selected from the *Heat Source* list on the AM Calculator, where a subsection called **Users heat sources** includes all previously saved heat sources. In the example, two calculators use

the **Gaussian - 316L - beam d 15um** user-defined heat source, and two use the **Double ellipsoidal - 316L - beam d 15um** user-defined heat source. The **Base plate temperature** and **Ambient temperature** is set to 353 K, while the **Layer thickness** is set to 10 μm .

Visualizations

Open the example project file to review the node setup on the **Project** window and the associated settings on the **Configuration** window for each node. For some types of projects, you can also adjust settings on the **Plot Renderer Configuration** window to preview results before performing the simulation. Click **Perform Tree** to generate plots and tables to see the results on the **Visualizations** window.



When you run (Perform) this example, it takes a few minutes for the calculations to complete.

There is a variety of information shown in the **Visualizations** window that can be viewed during configuration and after performing the calculation(s).



For this example, it is best to open and run this simulation to be able to view all the different plots and outputs to various tabs on both the various Configuration windows as well as the Visualizations window.

Gaussian Heat Source and Keyhole Model

The different processing conditions are selected to simulate both the conduction mode as well as the keyhole mode. For **Gaussian - 316L - beam d 15 um** heat source, with $P = 100$ W and scanning speed = 2800 mm/s, the dominant mode of heat transfer is conduction, which is why a shallow melt pool is obtained. The results from the simulations are fairly close to the ones from the experiments, as can be seen in *Table 1*.

With $P = 80$ W and scanning speed = 400 mm/s, a keyhole mode is observed in the experiments. This is also predicted from the simulations as can be seen in *Figure 107*.

A comparison of the melt pool depth from the simulations and the experiments for the latter case shows that the calibrated Gaussian heat source with the keyhole model predicts the melt pool depth with reasonable accuracy. However, it underpredicts the melt pool width. This is because fluid flow due to Marangoni forces is not included in these simulations, which probably causes the melt pool to widen in the experiments.

Calculator Name	Power [W]	Scanning Speed [mm/s]	Melt Pool Width		Melt Pool Depth	
			Simulation [μm]	Experiment [μm]	Simulation [μm]	Experiment [μm]
AM use calibrated Gaussian P100 u2800	100	2800	53.30	47.82	12.93	14.36
AM use calibrated Gaussian P80 u400	80	400	93.25	105	102.71	106.57

Table 1: A comparison of the melt pool dimensions from the simulations and experiments using the calibrated Gaussian heat source.

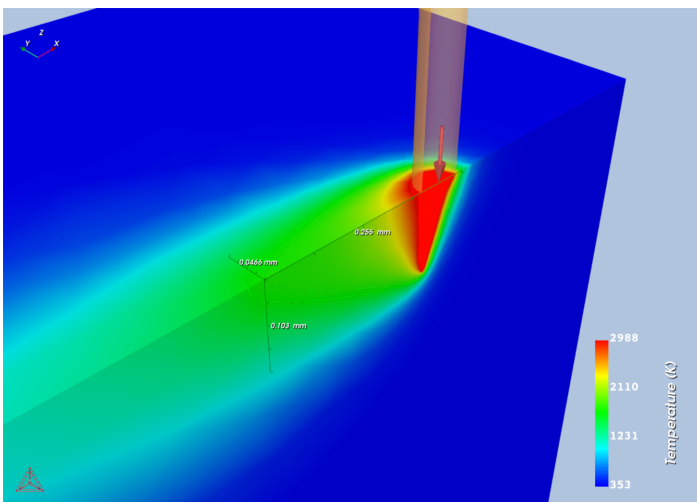

Figure 107: Steady-state temperature distribution around the melt pool for SS316L with $P = 80\text{ W}$ and scanning speed = 400 mm/s using the calibrated Gaussian heat source with the keyhole model. A keyhole can also be seen formed just below the location of the heat source.

Double Ellipsoidal Heat Source

For the **Double ellipsoidal - 316L - beam d 15 μm** heat source, two different processing conditions are selected to simulate both the conduction mode as well as the keyhole mode. For both processing conditions, the prediction of the melt pool size from the simulations is in fairly good agreement with the results from the experiments as can be seen in *Table 2*.

The temperature distribution using the calibrated double ellipsoidal heat source with $P = 80\text{ W}$ and scanning speed = 400 mm/s is shown in *Figure 108*.

Calculator Name	Power [W]	Scanning Speed [mm/s]	Melt Pool Width		Melt Pool Depth	
			Simulation [μm]	Experiment [μm]	Simulation [μm]	Experiment [μm]
AM use calibrated DE P80 u1200	100	1200	65.07	64.34	31.63	29.68
AM use calibrated DE P80 u400	80	400	103.65	105	112.29	106.57

Table 2: A comparison of the melt pool dimensions from the simulations and experiments using the calibrated double ellipsoidal heat source.

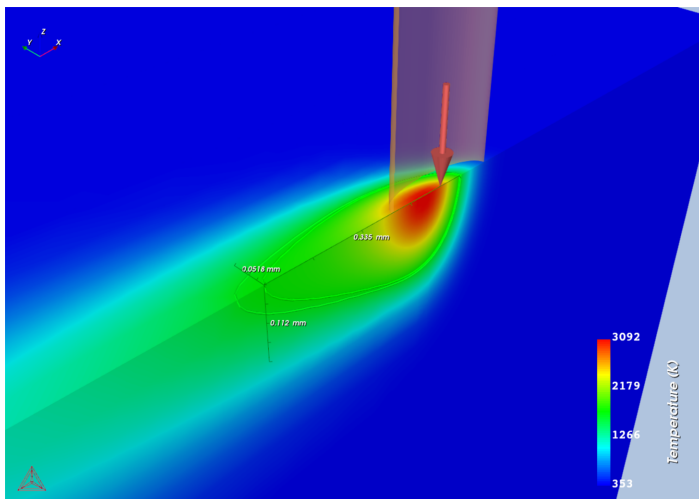

Figure 108: Steady-state temperature distribution around the melt pool for SS316L with $P = 80$ W and scanning speed = 400 mm/s using the calibrated double ellipsoidal heat source.

Reference

[2019Hu] Z. Hu, B. Nagarajan, X. Song, R. Huang, W. Zhai, J. Wei, Formation of SS316L Single Tracks in Micro Selective Laser Melting: Surface, Geometry, and Defects. Adv. Mater. Sci. Eng. 2019, Article ID 9451406, 1–9 (2019).

Other Resources



Read more about the [Additive Manufacturing \(AM\) Module](#) on our website including the details about database compatibility or to watch an [introductory webinar](#). You can also use the [Getting Started Guide](#) to learn about the key features available.



Many of our Graphical Mode examples have video tutorials, which you can access in a variety of ways. When in Thermo-Calc, from the menu select **Help → Video Tutorials**, or from the main My Project window, click **Video Tutorials**. Alternately, you can go to the [website](#) or our [YouTube channel](#).

AM_07: Batch Calculations for an IN718 Alloy

This example shows the use of the **AM Calculator** with a **Steady-state** mode and **Batch Calculation Type** where it compares calculated and measured melt pool dimensions. The experimental data are from the 2022 NIST AM-Bench Test Series [2022NIST] where single track experiments were performed on a IN718 bare plate at different power and scan speeds.

The use of different **Plot types** in this example include a **Parity plot**, **3D plot** showing the keyhole, and **Printability map**.



This example is part of a set using a **Steady-state** simulation with a **Gaussian** heat source, plus the **Keyhole model** including **Fluid flow**. These examples collectively show the use of **Batch** and **Grid** calculation types plus various plot types such as **Printability maps**, **Parity plots**, and **Melt pool vs energy density**. The examples are numbered AM_07 to AM_09b.

Project File and License Information

- Folder: **Additive Manufacturing**
- File name: `AM_07_Batch_IN718.tcu`



This example requires an Additive Manufacturing (AM) Module license.



Some examples (AM_01, AM_02, AM_03, and AM_06b) are available to all users. These examples can be run without an additional Additive Manufacturing license when you are in DEMO (demonstration) mode. However, the AM Module is not available with the Educational version of Thermo-Calc. Search the help for Available Options with the Additive Manufacturing (AM) Module.

Configuration and Calculation Set Up

Below highlights the main settings for this example.

The **Steady-state** simulation is selected and the **Fluid flow including Marangoni effect** checkbox is selected.

Configuration

IN718 AM

Conditions Material Properties Options

Steady-state Transient Transient with heat source from Steady-state

Global Settings

Gas pressure: 1.0 Atmospheres

Temperature unit: Celsius

Base plate temperature: 23.0

Ambient temperature: 23.0

Fluid flow including Marangoni effect:

Use separate material properties for powder: Powder density: 80.0 % of solid material

The *Heat Source* is set to **Gaussian** and uses the **Keyhole model**. The printers in the experiments had a beam diameter of $67\ \mu\text{m}$ so the Gaussian **Beam radius** is set to $33.5\ \mu\text{m}$. The **Absorptivity** is set to $30.0\ \%$.

Heat Source

Gaussian Absorptivity: User-defined 30.0 %

Beam radius: 33.5 μm

Use keyhole model Beam quality factor M^2 1.0

The **IN718** material is selected from the **Material Properties** library. The material properties are precalculated and stored as a built-in material **Library**.

Configuration

IN718 AM

Conditions Material Properties Options

Use data from Library IN718 Save Save As... Export to folder...

The **Batch Calculation Type** is used to set up all the conditions from the multiple experiments in a single calculation. The experimental *Power* and scan *Speed* as well as the measured melt pool *Width* and *Depth* were collected in a CSV file and read into the software. This data is then saved in the project file.

In the *Batch Experiment Data* table you can see that the power ranges between 245 W to 285 W and the scan speed ranges between 800 mm/s to 1200 mm/s.

Calculation Type

Single Point Heat Source Calibration Batch Grid

Batch Experiment Data

Experiment file delimiter Comma

#	Power (W)	Speed (mm/s)	P/V (J/mm)	Exp.width (μm)	Exp.depth (μm)	Use
1	285.000000	960.000000	0.296875	136.300000	139.700000	<input checked="" type="checkbox"/>
2	285.000000	1200.000000	0.237500	112.900000	109.700000	<input checked="" type="checkbox"/>
3	285.000000	800.000000	0.356250	156.100000	176.500000	<input checked="" type="checkbox"/>
4	325.000000	960.000000	0.338542	134.300000	166.100000	<input checked="" type="checkbox"/>
5	245.000000	960.000000	0.255208	129.400000	116.900000	<input checked="" type="checkbox"/>

Visualizations

Open the example project file to review the node setup on the **Project** window and the associated settings on the **Configuration** window for each node. For some types of projects, you can also adjust settings on the **Plot Renderer Configuration** window to preview results before performing the simulation. Click **Perform Tree** to generate plots and tables to see the results on the **Visualizations** window.



When you run (Perform) this example, it takes at least 30 minutes for the calculations to complete.



There is a wide variety of information shown both in the **Visualizations** and **Plot Renderer Configuration** windows that can be viewed during configuration and after performing the calculation(s). Not all views, such as the **Geometry** or previews, nor all additional output (i.e. plots) are shown in this section and it is recommended that you open and run the example to review all available options and results.

Parity Plot

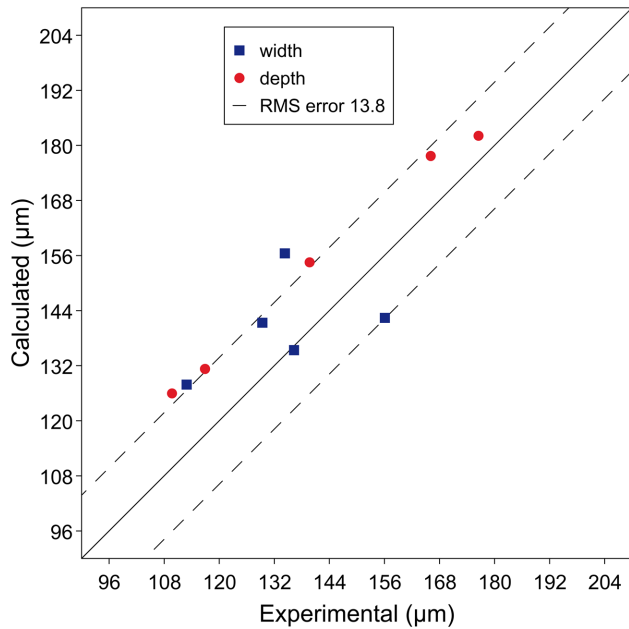

Figure 109: Parity plot comparing experimental versus calculated melt pool width and depth for all the experiments. The experiments are single tracks on bare plate IN718 with varied power and scan speed. The Root Mean Square (RMS) error can also be shown as a dashed line.

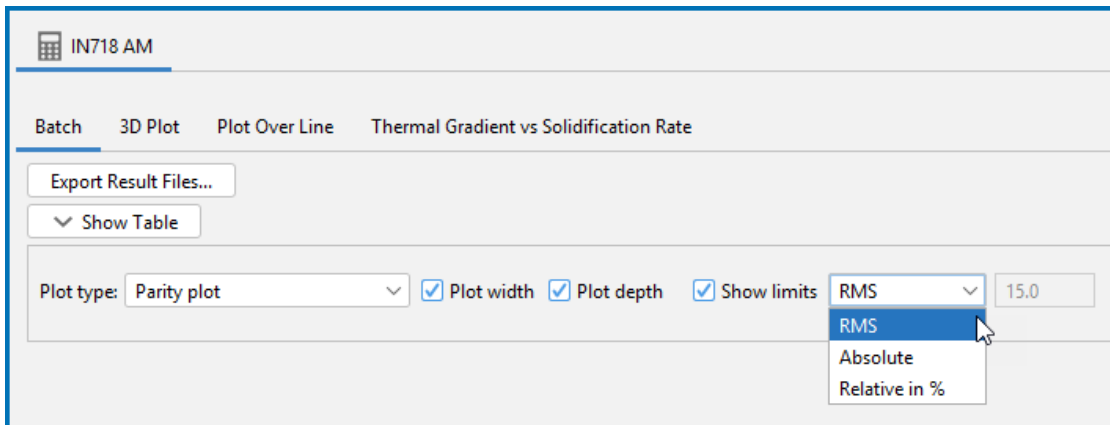

Figure 110: Alternatively, lines for user-defined Absolute or Relative in % error can be shown instead by selecting these options on the Configuration window.

3D Plot with Surface Colormap

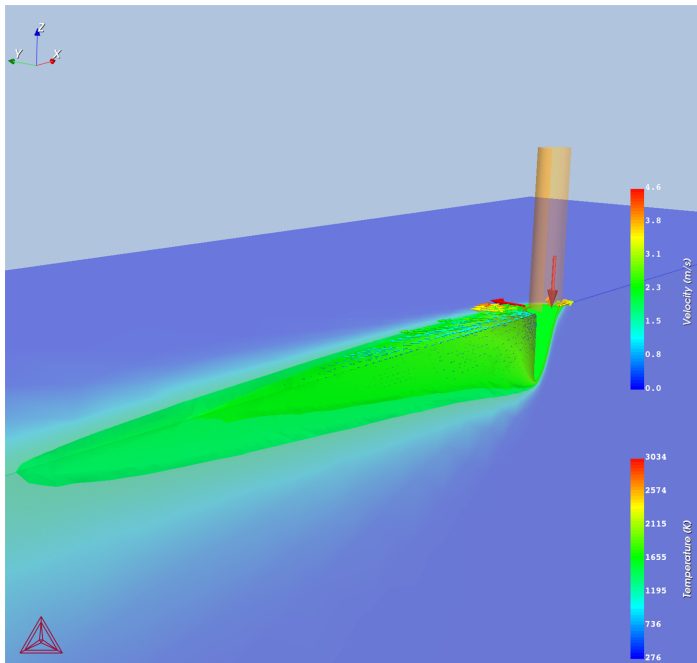

Figure 111: 3D plot showing a keyhole for the second simulation that uses power 285 W and scan speed 1200 mm/s.

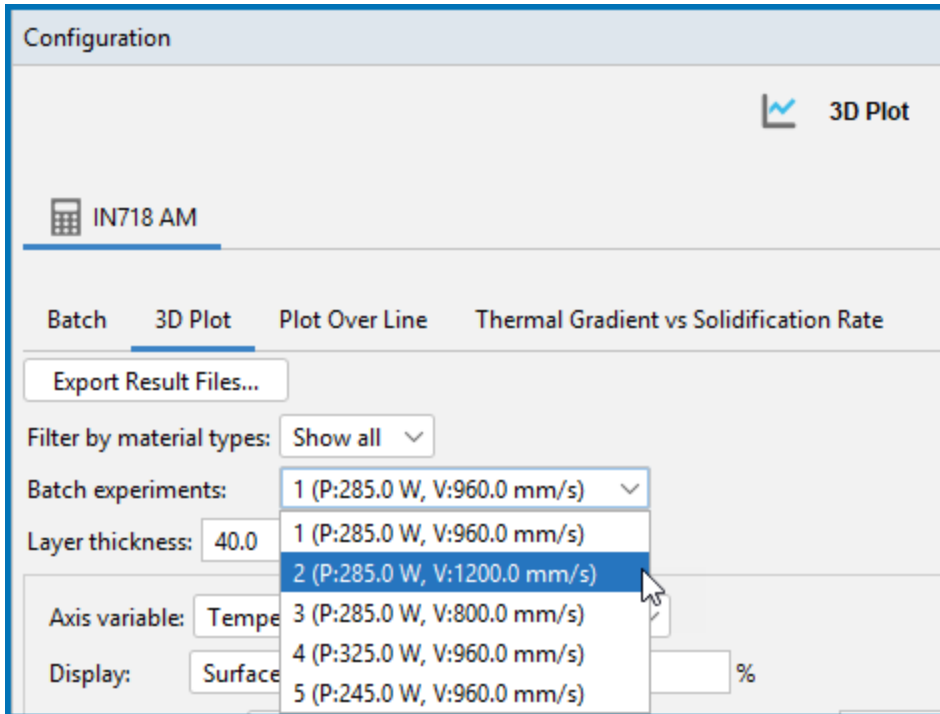

Figure 112: Selecting the Batch experiment number to display in the Visualizations window for the 3D plot shown in Figure 111.

Reference

[2022NIST] National Institute of Standards and Technology (NIST), Additive Manufacturing Benchmark Test Series (AM-Bench) (2022), (available at <https://www.nist.gov/ambench>).

Other Resources



Read more about the [Additive Manufacturing \(AM\) Module](#) on our website including the details about database compatibility or to watch an [introductory webinar](#). You can also use the [Getting Started Guide](#) to learn about the key features available.



Many of our Graphical Mode examples have video tutorials, which you can access in a variety of ways. When in Thermo-Calc, from the menu select **Help** → **Video Tutorials**, or from the main My Project window, click **Video Tutorials**. Alternately, you can go to the [website](#) or our [YouTube channel](#).

AM_08a: Grid Calculation for a Ti64 Alloy

This example shows the use of the **AM Calculator** with a **Steady-state** mode and **Grid Calculation Type** where it compares the calculated and measured printability map. Printability maps are also known as *process maps*. The experiments are from Dilip *et. al* [2017Dil] where they performed single track experiments with the alloy Ti64 at different power and scan speeds. They also printed cubes and performed measurements of the porosity amounts for each experimental condition.

The use of different **Plot types** in this example include a **Printability map** and a **3D plot** with surface colormap.



This example is part of a set using a **Steady-state** simulation with a **Gaussian** heat source, plus the **Keyhole model** including **Fluid flow**. These examples collectively show the use of **Batch** and **Grid** calculation types plus various plot types such as **Printability maps**, **Parity plots**, and **Melt pool vs energy density**. The examples are numbered AM_07 to AM_09b.

Project File and License Information

- Folder: **Additive Manufacturing**
- File name: AM_08a_Printability_Map_Ti64.tcu



This example requires an Additive Manufacturing (AM) Module license.

Configuration and Calculation Set Up

Below highlights some of the settings for this example to compare with experimental data of Ti64.



This example builds on the previous one (AM_07) and it is recommended to review this and to open the example file to locate and follow along for the settings described here and found on the **Configuration** window.

The **Steady-state** calculation includes **Fluid flow**.

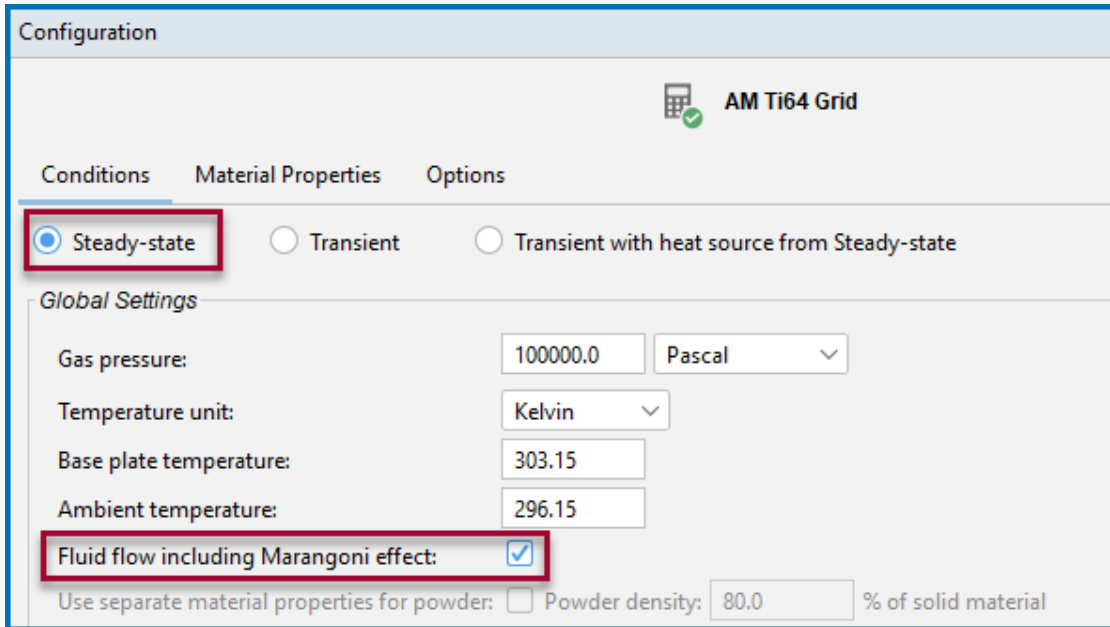

Configuration

AM Ti64 Grid

Conditions Material Properties Options

Steady-state Transient Transient with heat source from Steady-state

Global Settings

Gas pressure: 100000.0 Pascal

Temperature unit: Kelvin

Base plate temperature: 303.15

Ambient temperature: 296.15

Fluid flow including Marangoni effect:

Use separate material properties for powder: Powder density: 80.0 % of solid material

The *Heat Source* is set to **Gaussian** and uses the **Keyhole model**. The printers in the experiments had a beam diameter of 100 μm so the Gaussian **Beam radius** is set to 50 μm . The **Absorptivity** is set to **Calculated**.

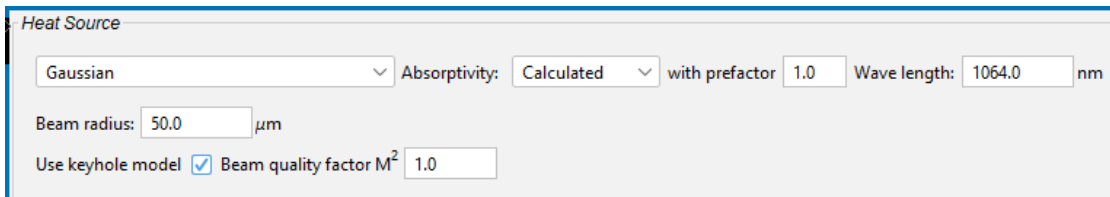

Heat Source

Gaussian Absorptivity: Calculated with prefactor 1.0 Wave length: 1064.0 nm

Beam radius: 50.0 μm

Use keyhole model Beam quality factor M^2 1.0

The **Ti6Al4V** from **project file** material is selected from the **Material Properties** library. The material properties are precalculated and stored as a built-in material **Library**.

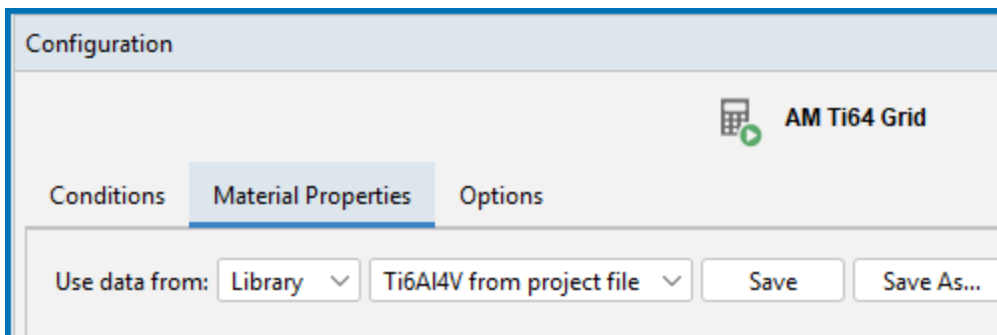

Configuration

AM Ti64 Grid

Conditions Material Properties Options

Use data from: Library Ti6Al4V from project file Save Save As...

The **Grid Calculation Type** is used to cover all the conditions from the experiments in a single calculation. The **Power** ranges between 50–200 W and the **Scanning speed** ranges between 500–1200 mm/s.

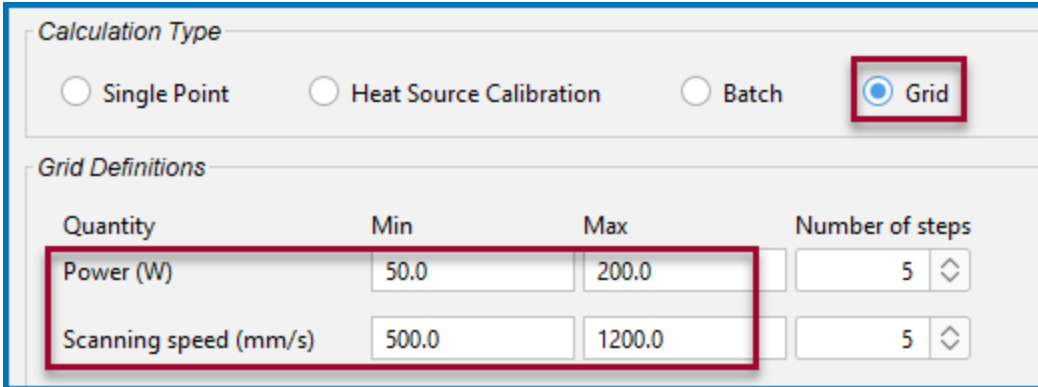

Calculation Type

Single Point Heat Source Calibration Batch Grid

Grid Definitions

Quantity	Min	Max	Number of steps
Power (W)	50.0	200.0	5
Scanning speed (mm/s)	500.0	1200.0	5

Visualizations

Open the example project file to review the node setup on the **Project** window and the associated settings on the **Configuration** window for each node. For some types of projects, you can also adjust settings on the **Plot Renderer Configuration** window to preview results before performing the simulation. Click **Perform Tree** to generate plots and tables to see the results on the **Visualizations** window.



When you run (Perform) this example, it can take around two hours to complete the calculations.



There is a wide variety of information shown both in the **Visualizations** and **Plot Renderer Configuration** windows that can be viewed during configuration and after performing the calculation(s). Not all views, such as the **Geometry** or previews, nor all additional output (i.e. plots) are shown in this section and it is recommended that you open and run the example to review all available options and results.

Plot Renderer Configuration Window

The combined results from the **Grid** calculation can be viewed under the matching **Grid** tab on the Plot Renderer **Configuration** window where it is set to use the **Printability map** plot type. In this example, the **Plot Renderer** node is renamed to **Printability map** in the **Project** window.

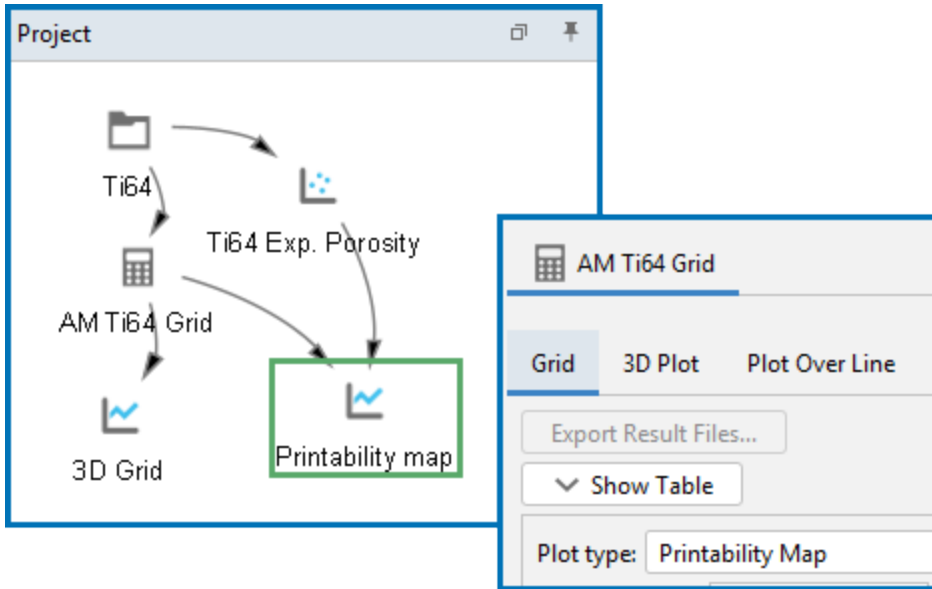

The experimental value of 30 μm powder thickness (**Layer thickness**) and 100 μm for the **Hatch distance** seems to be too big to produce dense builds according to this lack of fusion criteria. Full density can then in principle only be achieved by melting the regions between tracks by shifting the layers printed on top so the full depth of the melt pool covers unmelted regions.

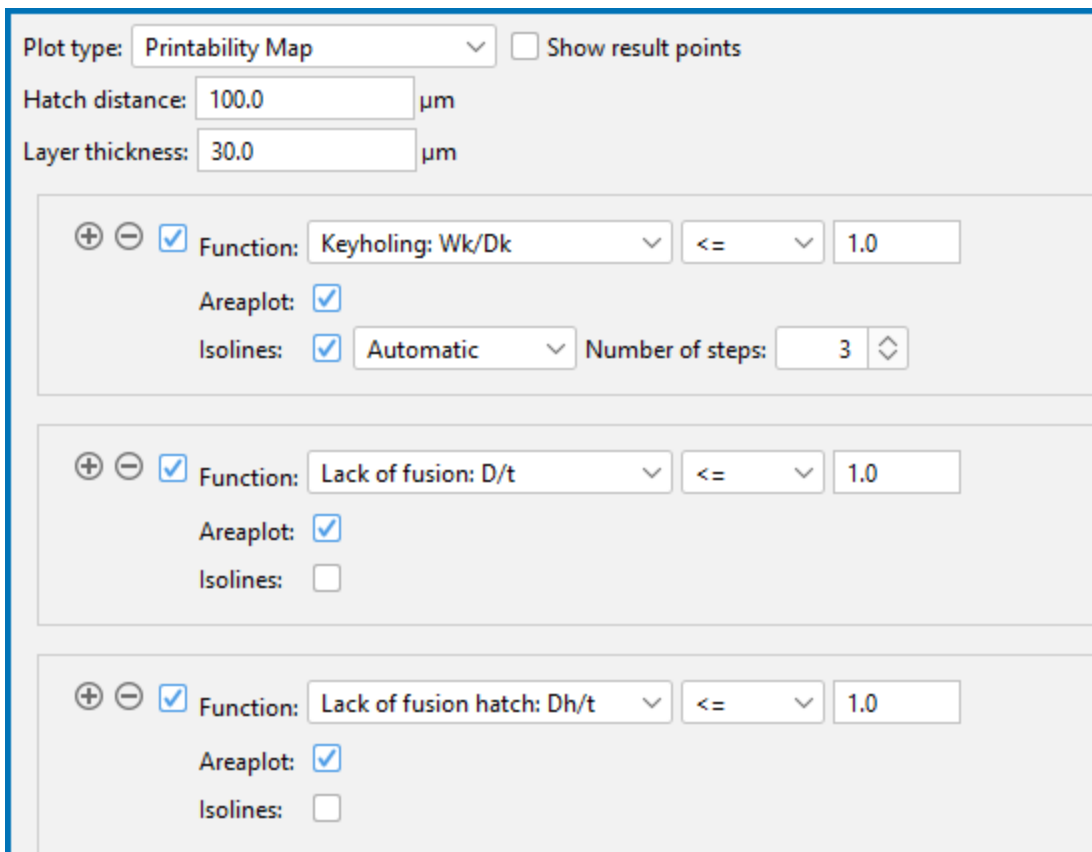

Printability Map and 3D Plot



There is a video tutorial about the **Printability Map** on our [website](#) and on our [YouTube channel](#). It is also included in the Additive Manufacturing Module [YouTube playlist](#).

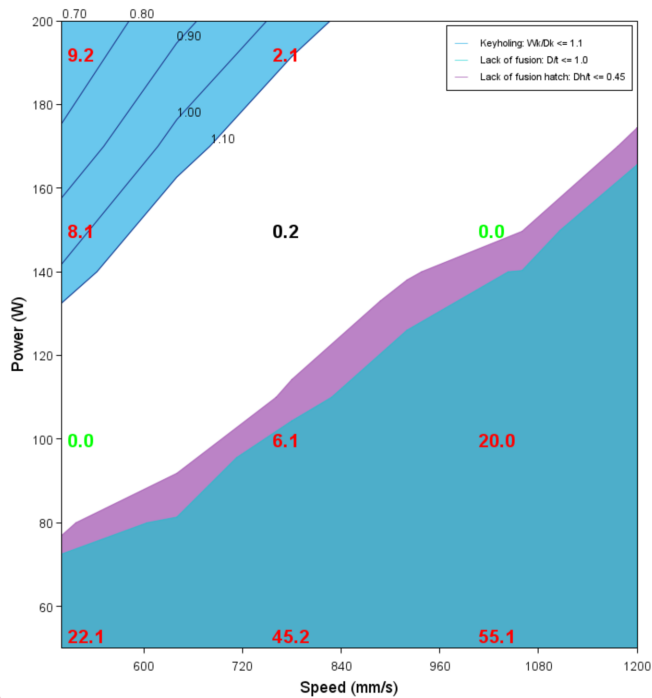

Figure 113: The calculated printability map for Ti64 showing the regions for keyholing porosity (upper left) and lack of fusion porosity to the lower right. The labels show the measured amount of porosity. Labels in red show regions with severe amounts of porosity and labels in black/green show regions with little or no defects.

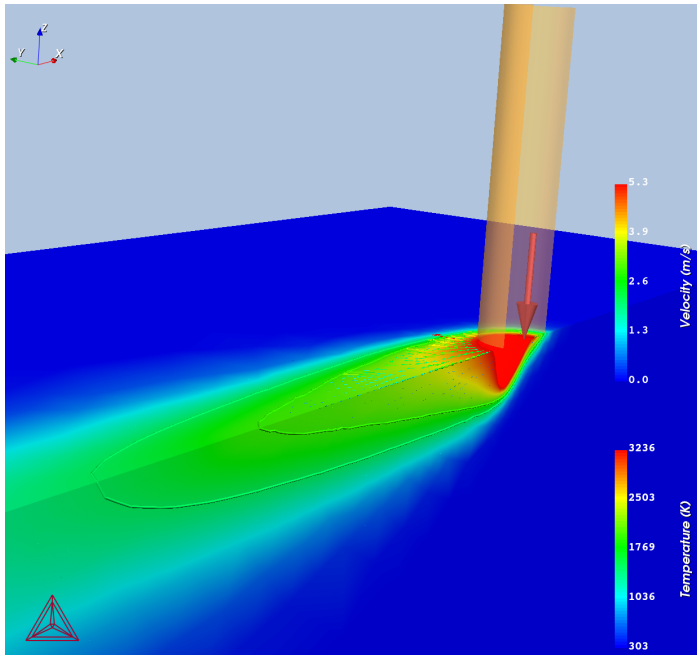

Figure 114: 3D plot showing a keyhole for the simulation that uses power 200 W and scan speed 1200 mm/s.

Reference

[2017Dil] J. J. S. Dilip, S. Zhang, C. Teng, K. Zeng, C. Robinson, D. Pal, B. Stucker, Influence of processing parameters on the evolution of melt pool, porosity, and microstructures in Ti-6Al-4V alloy parts fabricated by selective laser melting. *Prog. Addit. Manuf.* 2, 157–167 (2017).

Other Resources



Read more about the [Additive Manufacturing \(AM\) Module](#) on our website including the details about database compatibility or to watch an [introductory webinar](#). You can also use the [Getting Started Guide](#) to learn about the key features available.

AM_08b: Batch Calculations for a Ti64 Alloy

This example shows the use of the **AM Calculator** with a **Steady-state** mode and **Batch Calculation Type** where it compares the calculated and measured melt pool dimensions. The experiments are from Dilip *et. al* [2017Dil] where they performed single track experiments with the alloy Ti64 at different power and scan speeds.

The use of different **Plot types** in this example include a **Parity plot**, **Melt pool vs energy density**, **3D plot** showing the keyhole, and **Printability map**.



This example is part of a set using a **Steady-state** simulation with a **Gaussian** heat source, plus the **Keyhole model** including **Fluid flow**. These examples collectively show the use of **Batch** and **Grid** calculation types plus various plot types such as **Printability maps**, **Parity plots**, and **Melt pool vs energy density**. The examples are numbered AM_07 to AM_09b.

Project File and License Information

- Folder: **Additive Manufacturing**
- File name: AM_08b_Batch_Ti64.tcu



This example requires an Additive Manufacturing (AM) Module license.

Configuration and Calculation Set Up



Below highlights some of the settings for this example. This example builds on the previous ones (AM_07 and AM_08a) and it is recommended to review these and to open the example file to locate and follow along for the settings described here and found on the **Configuration** window.

The **Steady-state** calculation is configured with the **Gaussian Heat Source** with the **Keyhole model** and includes **Fluid flow**. The printers had a beam diameter of 100 μm so the Gaussian **Beam radius** is set to 50 μm . The **Absorptivity** is set to 27 %.

The **Ti6Al4V** material is selected from the **Material Properties** library. The material properties are precalculated and stored as a built-in material **Library**.

The **Batch Calculation Type** is used to set up all the conditions from the experiments in a single calculation. The experimental *Power* and scan *Speed* as well as the measured melt pool *Width* and *Depth* were collected in a CSV file and read into the software. This data is then saved in the project file.

In the *Batch Experiment Data* table (see [Visualizing the Batch Calculation Experimental Data](#)) you can see that the power ranges between 50–195 W and the scan speed ranges between 500–1200 mm/s.

Visualizations

Open the example project file to review the node setup on the **Project** window and the associated settings on the **Configuration** window for each node. For some types of projects, you can also adjust settings on the **Plot Renderer Configuration** window to preview results before performing the simulation. Click **Perform Tree** to generate plots and tables to see the results on the **Visualizations** window.



When you run (Perform) this example, it takes at least 30 minutes for the calculations to complete.



There is a wide variety of information shown both in the **Visualizations** and **Plot Renderer Configuration** windows that can be viewed during configuration and after performing the calculation(s). Not all views, such as the **Geometry** or previews, nor all additional output (i.e. plots) are shown in this section and it is recommended that you open and run the example to review all available options and results.

Visualizing the Batch Calculation Experimental Data

During the set up of a calculation, the *Batch Experiment Data* is imported into the **AM Calculator Configuration** window, where you can review the data and choose to include or exclude data points by selecting and deselecting the checkboxes as needed in the **Use** column (see [Figure 115](#)). At the same time, you can observe the change as this is updated in the **Visualizations** window (see [Figure 116](#)). Data can also be entered directly into the table.

Calculation Type

Single Point
 Heat Source Calibration
 Batch
 Grid

Batch Experiment Data

Experiment file delimiter Comma

#	Power (W)	Speed (mm/s)	P/V (J/mm)	Exp.width (μm)	Exp.depth (μm)	Use
1	50.000000	500.000000	0.100000	67.379660	16.058920	<input checked="" type="checkbox"/>
2	50.000000	750.000000	0.066667	50.318180	11.830310	<input checked="" type="checkbox"/>
3	50.000000	1000.000000	0.050000	47.357410	9.654352	<input checked="" type="checkbox"/>
4	50.000000	1200.000000	0.041667	45.508170	5.108316	<input checked="" type="checkbox"/>
5	100.000000	500.000000	0.200000	118.025200	44.462060	<input checked="" type="checkbox"/>
6	100.000000	750.000000	0.133333	98.663500	32.019900	<input checked="" type="checkbox"/>
7	100.000000	1000.000000	0.100000	75.846620	24.027610	<input checked="" type="checkbox"/>
8	100.000000	1200.000000	0.083333	72.846300	21.534230	<input checked="" type="checkbox"/>
9	150.000000	500.000000	0.300000	145.364300	101.268300	<input checked="" type="checkbox"/>
10	150.000000	750.000000	0.200000	135.499000	72.058650	<input checked="" type="checkbox"/>

Figure 115: The experimental data used for the Batch calculation for the single track experiments of Ti64 is imported to the AM Calculator table where you can review the data points and include or exclude as needed using the checkboxes.

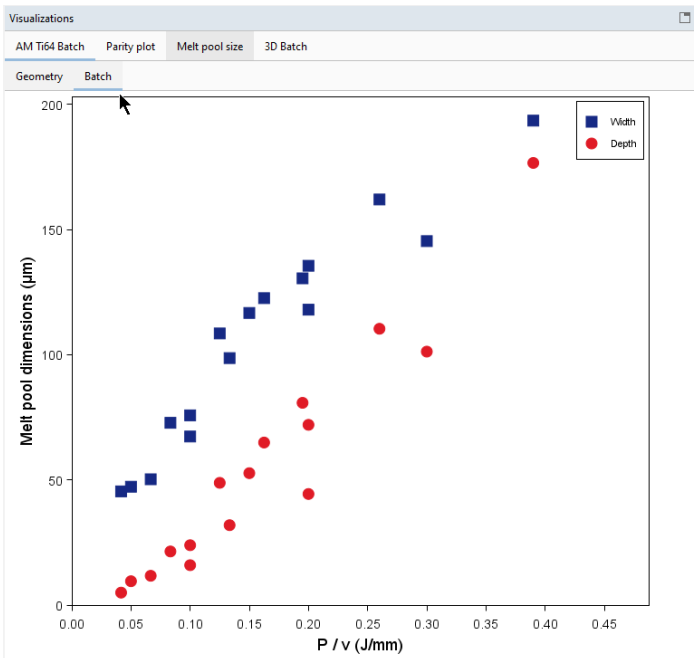

Figure 116: The visualization of the experimental melt pool dimensions are shown as a function of the energy density P/v. You can adjust the selected points in the Batch Experiment Data table and watch the updates dynamically in this window.

Parity, Melt Pool, and 3D Plot

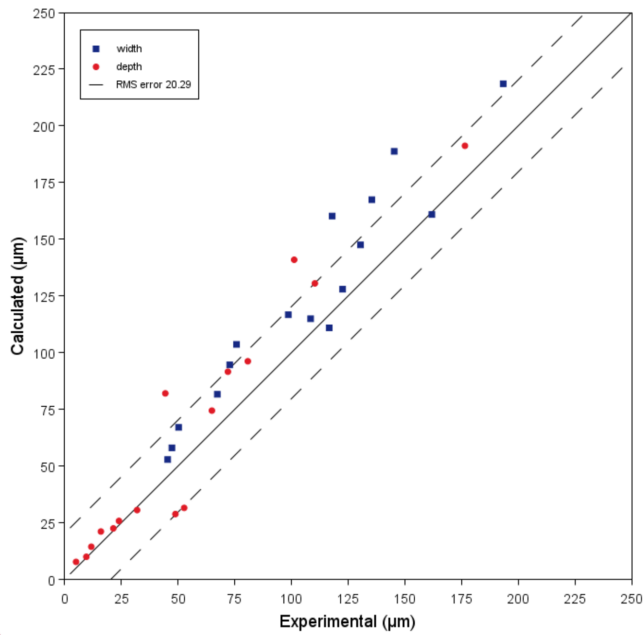

Figure 117: Parity plot comparing experimental versus calculated melt pool width and depth for all the Batch calculations. The experiments are single tracks with Ti64 with varied power and scan speed.

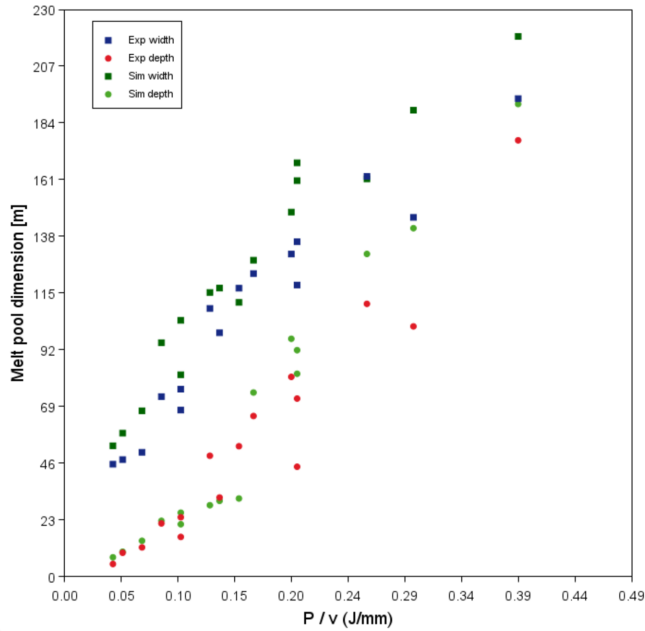

Figure 118: Plot comparing experimental versus calculated melt pool dimensions for all the Batch calculations. The experiments are single tracks with Ti64 with varied power and scan speed. The melt pool width and depth are shown on the Y-axis and the energy density (P/v) on the X-axis.

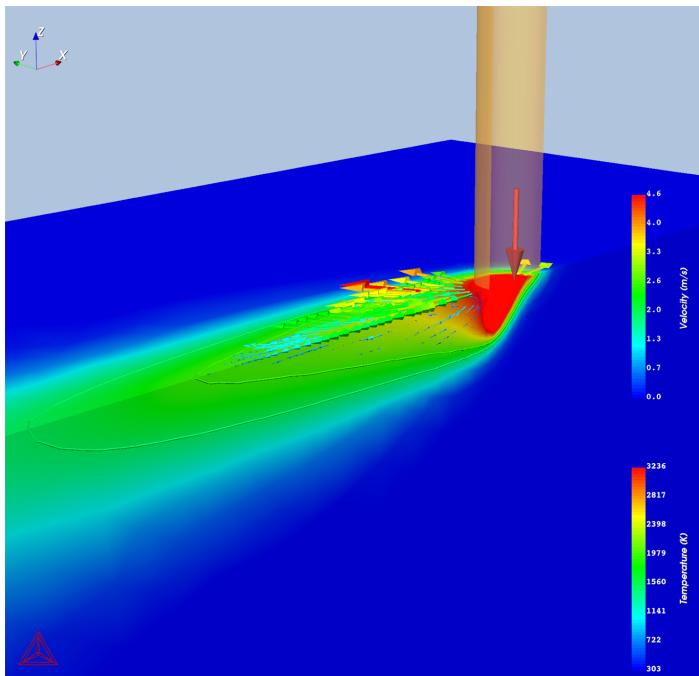

Figure 119: 3D plot showing a keyhole for the 15th simulation that uses power 195 W and scan speed 1000 mm/s.

Reference

[2017Dil] J. J. S. Dilip, S. Zhang, C. Teng, K. Zeng, C. Robinson, D. Pal, B. Stucker, Influence of processing parameters on the evolution of melt pool, porosity, and microstructures in Ti-6Al-4V alloy parts fabricated by selective laser melting. Prog. Addit. Manuf. 2, 157–167 (2017).

Other Resources



Read more about the [Additive Manufacturing \(AM\) Module](#) on our website including the details about database compatibility or to watch an [introductory webinar](#). You can also use the [Getting Started Guide](#) to learn about the key features available.



Many of our Graphical Mode examples have video tutorials, which you can access in a variety of ways. When in Thermo-Calc, from the menu select **Help** → **Video Tutorials**, or from the main My Project window, click **Video Tutorials**. Alternately, you can go to the [website](#) or our [YouTube channel](#).

AM_09a: Grid Calculation for an SS316L Alloy

This example shows the use of the **AM Calculator** with a **Steady-state** mode and **Grid Calculation Type** where it compares the calculated and measured printability map. Printability maps are also known as *process maps*. The experiments are from Hu *et. al* [2019Hu] where they performed single track experiments with the alloy SS316L at different power and scan speeds.

The use of different **Plot types** in this example include a **Printability map** and a **3D plot** with surface colormap.



This example is part of a set using a **Steady-state** simulation with a **Gaussian** heat source, plus the **Keyhole model** including **Fluid flow**. These examples collectively show the use of **Batch** and **Grid** calculation types plus various plot types such as **Printability maps**, **Parity plots**, and **Melt pool vs energy density**. The examples are numbered AM_07 to AM_09b.

Project File and License Information

- Folder: **Additive Manufacturing**
- File name: AM_09a_Printability_Map_316L.tcu



This example requires an Additive Manufacturing (AM) Module license.

Configuration and Calculation Set Up



Below highlights some of the settings for this example. This example builds on the previous ones (AM_07, AM_08a, and AM_08b) and it is recommended to review these and to open the example file to locate and follow along for the settings described here and found on the **Configuration** window.

The **Steady-state** calculation is configured with the **Gaussian Heat Source** with the **Keyhole model** and includes **Fluid flow**.

The Gaussian **Beam radius** is set to 22 μm . The **Absorptivity** is set to 30 % and in the *Scanning Strategy* section, the powder **Layer thickness** is set to 10 μm .

The **SS316L** material is selected from the **Material Properties** library. The material properties are precalculated and stored as a built-in material **Library**.

The **Grid Calculation Type** is used to cover all the conditions from the experiments in a single calculation. The **Power** ranges between 40–100 W and the **Scanning speed** ranges between 400–3000 mm/s.

Visualizations

Open the example project file to review the node setup on the **Project** window and the associated settings on the **Configuration** window for each node. For some types of projects, you can also adjust settings on the **Plot Renderer Configuration** window to preview results before performing the simulation. Click **Perform Tree** to generate plots and tables to see the results on the **Visualizations** window.



When you run (Perform) this example, it can take around two hours to complete the calculations.



There is a wide variety of information shown both in the **Visualizations** and **Plot Renderer Configuration** windows that can be viewed during configuration and after performing the calculation(s). Not all views, such as the **Geometry** or previews, nor all additional output (i.e. plots) are shown in this section and it is recommended that you open and run the example to review all available options and results.

Plot Renderer Configuration Window

The combined results from the **Grid** calculation can be viewed under the matching **Grid** tab on the Plot Renderer **Configuration** window where it is configured to use the **Printability map** plot type. In this example, the **Plot Renderer** node is renamed to **Printability map** in the **Project** window.

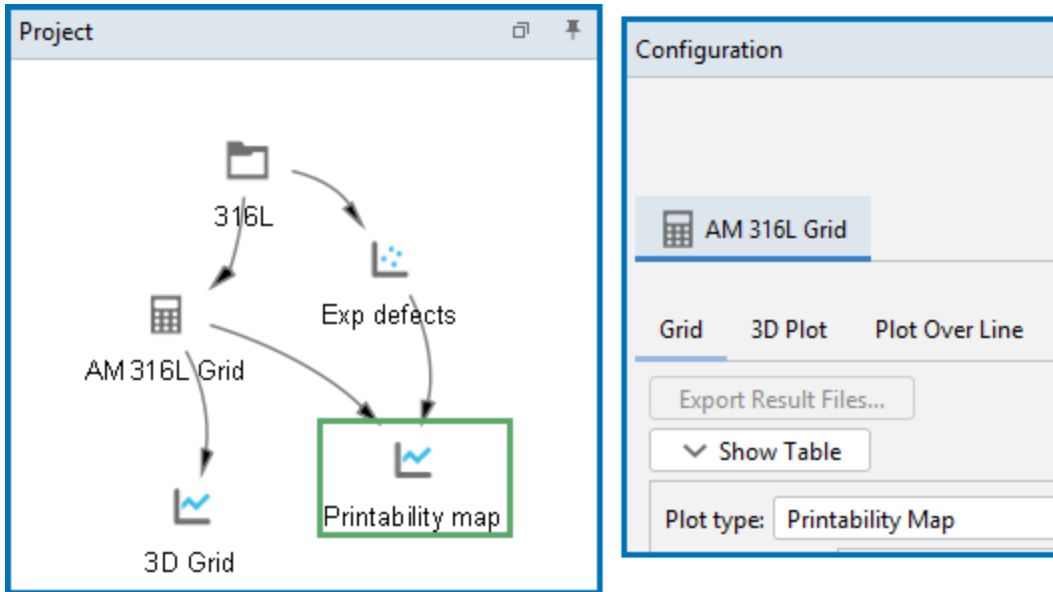

Next each **Function** is defined and limits were adjusted to match the experimental regions of keyholing and lack of fusion porosity.

- The keyholing limit (**Keyholing: Wk/Dk**) is kept at default 1.0.
- The **Lack of fusion: D/t** is increased from default of 1.0 to 1.3.
- The experiments were only single-track and the lack of fusion at half of the hatch distance (**Lack of fusion hatch: Dh/t**) is kept at default 1.0 and only included together with the **Hatch distance** of 35 μm for demonstration purposes.

Plot type: Show result points

Hatch distance: μm

Layer thickness: μm

Function:

Areaplot:

Isolines: Number of steps:

Function:

Areaplot:

Isolines: Number of steps:

Function:

Areaplot:

Isolines:

Figure 120: The settings for the printability map with the Function limits defined for keyholing, lack of fusion, and lack of fusion at half of the hatch distance (as described in the text).

Printability Map and 3D Plot



There is a video tutorial about the **Printability Map** on our [website](#) and on our [YouTube channel](#). It is also included in the Additive Manufacturing Module [YouTube playlist](#).

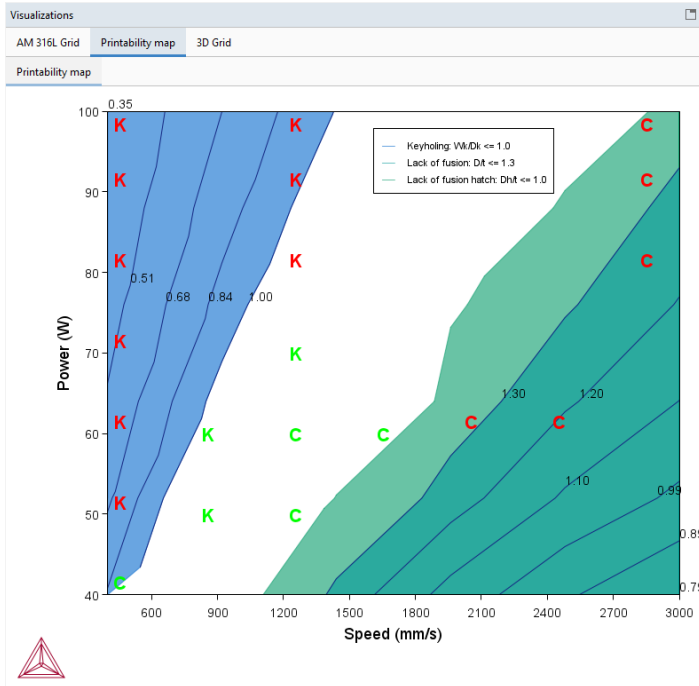

Figure 121: Printability map for 316L showing regions of keyholing and lack-of-fusion. Experimental information from Hu et. al. [2019Hu] overlaid as coloured labels showing keyhole porosity (K), conduction mode with lack-of-fusion porosity (C). Green labels showing experiments without defects for conduction mode (C) and keyhole mode (K).

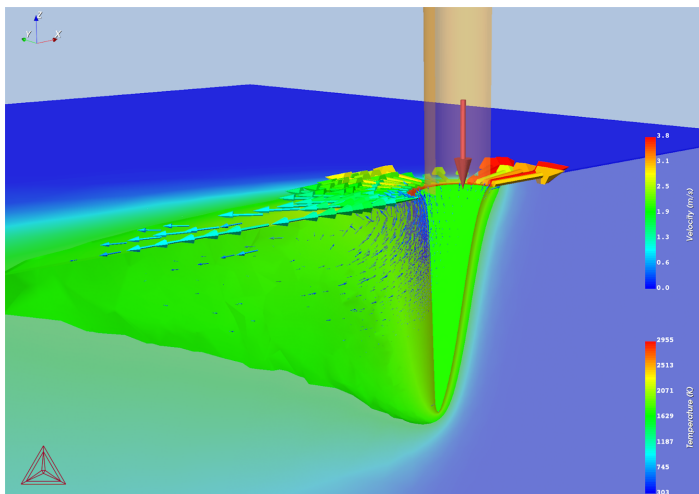

Figure 122: 3D plot showing a keyhole for the simulation that uses power 100 W and scan speed 400 mm/s.

Reference

[2019Hu] Z. Hu, B. Nagarajan, X. Song, R. Huang, W. Zhai, J. Wei, Formation of SS316L Single Tracks in Micro Selective Laser Melting: Surface, Geometry, and Defects. Adv. Mater. Sci. Eng. 2019, 1–9 (2019).

Other Resources



Read more about the [Additive Manufacturing \(AM\) Module](#) on our website including the details about database compatibility or to watch an [introductory webinar](#). You can also use the [Getting Started Guide](#) to learn about the key features available.

AM_09b: Batch Calculations for an SS316L Alloy

This example shows the use of the **AM Calculator** with a **Steady-state** mode and **Batch Calculation Type** where it compares the calculated and measured melt pool dimensions. The experiments are from Hu *et. al* 2019 where they performed single track experiments with the alloy SS316L at different power and scan speeds.

The use of different **Plot types** in this example include a **Parity plot**, **Melt pool vs energy density**, **3D plot** showing the keyhole, and **Printability map**.



This example is part of a set using a **Steady-state** simulation with a **Gaussian** heat source, plus the **Keyhole model** including **Fluid flow**. These examples collectively show the use of **Batch** and **Grid** calculation types plus various plot types such as **Printability maps**, **Parity plots**, and **Melt pool vs energy density**. The examples are numbered AM_07 to AM_09b.

Project File and License Information

- Folder: **Additive Manufacturing**
- File name: AM_09b_Batch_316L.tcu



This example requires an Additive Manufacturing (AM) Module license.

Configuration and Calculation Set Up



Below highlights some of the settings for this example. This example builds on the previous ones (AM_07, AM_08a, AM_08b, and AM_09a) and it is recommended to review these and to open the example file to locate and follow along for the settings described here and found on the **Configuration** window.

The **Steady-state** calculation is configured with the **Gaussian Heat Source** with the **Keyhole model** and includes **Fluid flow**.

The Gaussian **Beam radius** is set to 22 μm . The **Absorptivity** is set to 30 % and in the **Scanning Strategy** section, the powder **Layer thickness** is set to 10 μm .

The **SS316L** material is selected from the **Material Properties** library. The material properties are precalculated and stored as a built-in material **Library**.

The **Batch Calculation Type** is used to set up all the conditions from the experiments in a single calculation. The experimental *Power* and scan *Speed* as well as the measured melt pool *Width* and *Depth* were collected in a CSV file and read into the software. This data is then saved in the project file.

In the *Batch Experiment Data* table the power ranges between 50–100 W and the scan speed ranges between 400–2800 mm/s.

Visualizations



There is a video tutorial about the **Printability Map** on our [website](#) and on our [YouTube channel](#). It is also included in the Additive Manufacturing Module [YouTube playlist](#).

Open the example project file to review the node setup on the **Project** window and the associated settings on the **Configuration** window for each node. For some types of projects, you can also adjust settings on the **Plot Renderer Configuration** window to preview results before performing the simulation. Click **Perform Tree** to generate plots and tables to see the results on the **Visualizations** window.



When you run (Perform) this example, it can take about an hour to complete the calculations.





There is a wide variety of information shown both in the **Visualizations** and **Plot Renderer Configuration** windows that can be viewed during configuration and after performing the calculation(s). Not all views, such as the **Geometry** or previews, nor all additional output (i.e. plots) are shown in this section and it is recommended that you open and run the example to review all available options and results.

Visualizing the Batch Calculation Experimental Data

During the set up of this calculation, the *Batch Experiment Data* is imported into the AM Calculator **Configuration** window, where you can review the data and choose to include or exclude data points by selecting and deselecting the checkboxes as needed in the **Use** column. At the same time, you can observe the change as this is updated in the **Visualizations** window.

Project

Configuration

 316L
 AM 316L Batch

Batch Experiment Data

Experiment file

#	Power (W)	Speed (mm/s)	P/V (J/mm)	Exp.width (μm)	Exp.depth (μm)	Use
1	60.000000	2400.000000	0.025000	36.842110	9.444444	<input checked="" type="checkbox"/>
2	60.000000	2000.000000	0.030000	39.009290	10.555560	<input checked="" type="checkbox"/>
3	50.000000	1200.000000	0.041667	51.075950	9.303797	<input checked="" type="checkbox"/>
4	60.000000	1600.000000	0.037500	46.439630	11.666670	<input checked="" type="checkbox"/>

Figure 123: The experimental data used for the Batch calculation for the single track experiments of SS316L is imported to the AM Calculator table where you can review the data points and include or exclude as needed using the checkboxes.

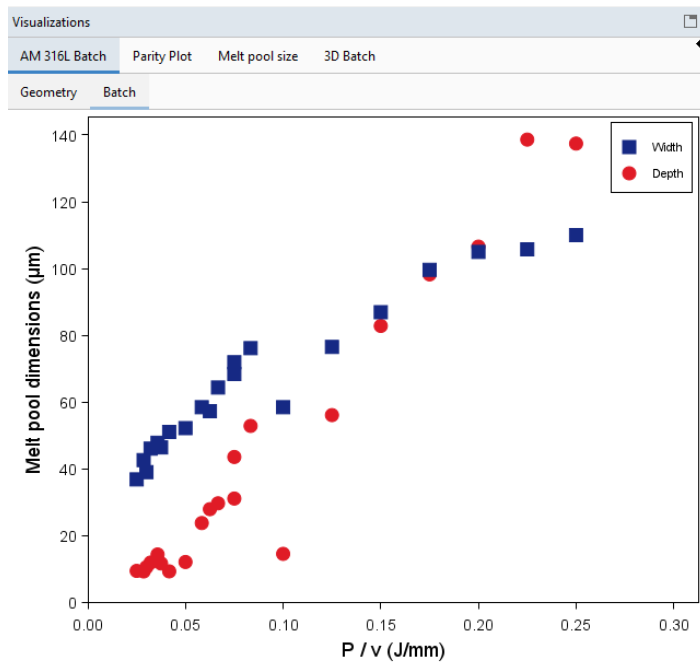

Figure 124: The visualization of the experimental melt pool dimensions are shown as a function of the energy density P/v. You can adjust the selected points in the Batch Experiment Data table and watch the updates dynamically in this window.

Parity, Melt Pool, and 3D Plot

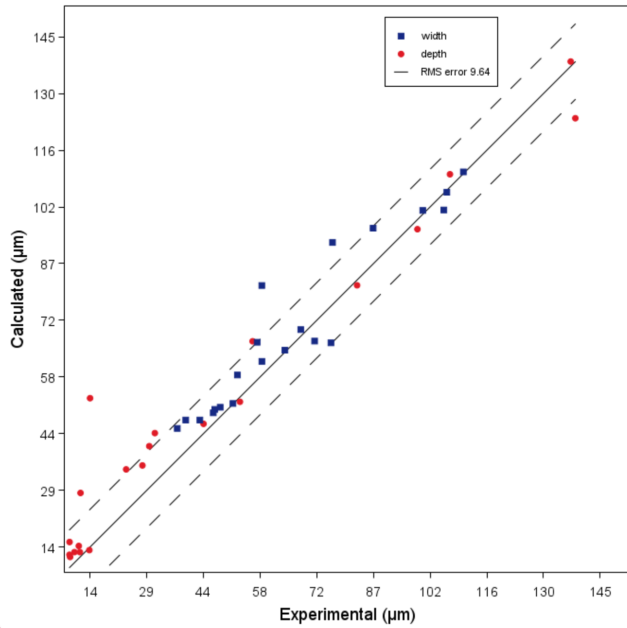

Figure 125: Parity plot comparing experimental versus calculated melt pool width and depth for all the Batch calculations. The experiments are single tracks with SS316L with varied power and scan speed.

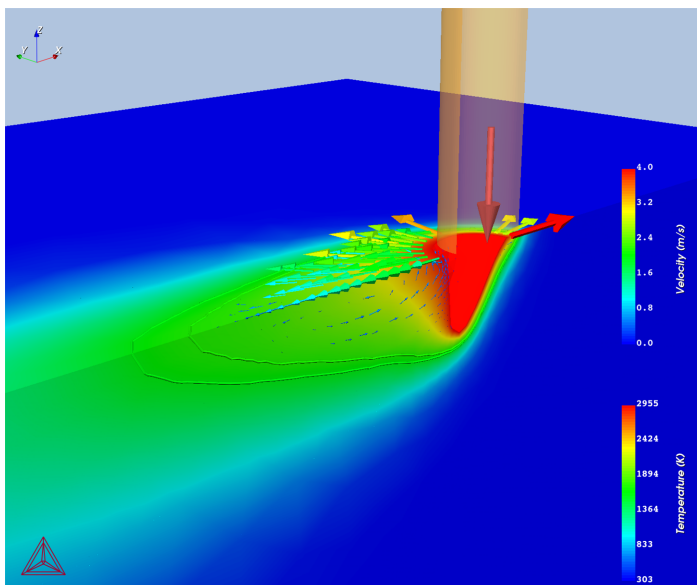

Figure 126: 3D plot showing a keyhole for the 12th simulation that uses power 60 W and scan speed 800 mm/s.

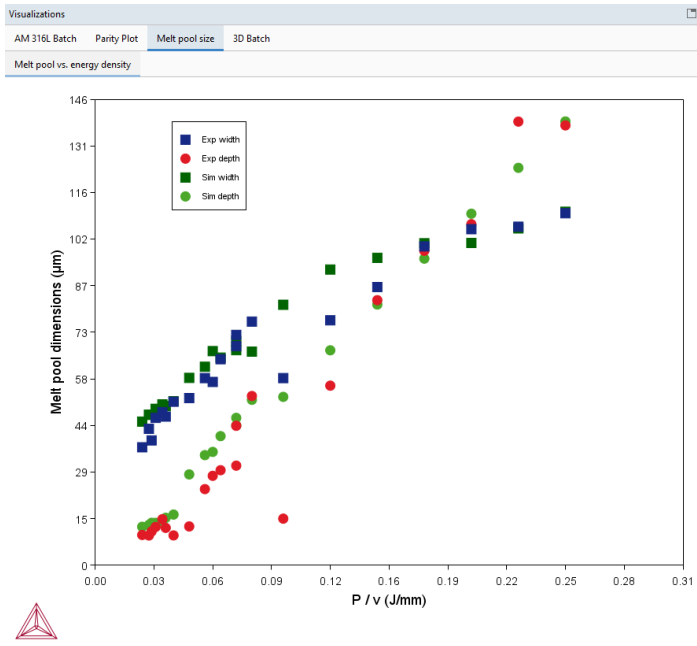

Figure 127: Plot comparing experimental versus calculated melt pool dimensions for all the Batch calculations. The experiments are single tracks with SS316L with varied power and scan speed. The melt pool width and depth are shown on the Y-axis and the energy density (P/v) on the X-axis.

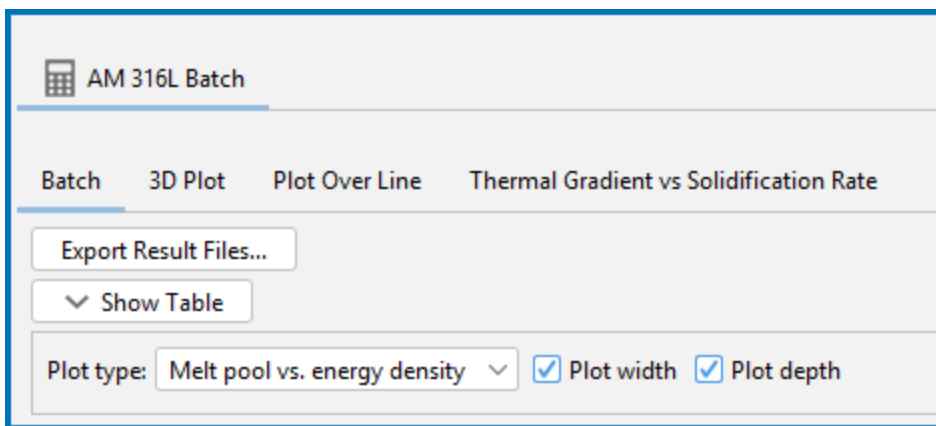

Figure 128: For the plot, you can choose what to include on the plot, to show width and/or depth by selecting the relevant checkboxes on the Configuration window.

Reference

[2019Hu] Z. Hu, B. Nagarajan, X. Song, R. Huang, W. Zhai, J. Wei, Formation of SS316L Single Tracks in Micro Selective Laser Melting: Surface, Geometry, and Defects. *Adv. Mater. Sci. Eng.* 2019, 1–9 (2019).

Other Resources



Read more about the [Additive Manufacturing \(AM\) Module](#) on our website including the details about database compatibility or to watch an [introductory webinar](#). You can also use the [Getting Started Guide](#) to learn about the key features available.

AM_10: CET Transition in an IN718 Alloy

The example uses a **Scheil Calculator**, **AM Calculator**, and the **Property Model Calculator** with the **Columnar to Equiaxed Transition** Property Model to compare calculated CET curves for an IN718 alloy (from example PM_G_17) with the solidification conditions of the melt pool in the AM simulation.



For more background about this Property Model, search the Help or the main Thermo-Calc documentation set for *About the Columnar to Equiaxed Transition (CET) model*.



This example is similar to, and based on, example *PM_G_17: Columnar to Equiaxed Transition of an IN718 Alloy*. This is available from the **Property Models** → **General** folder.

A Scheil with solute trapping calculation is done first on the **Scheil Calculator** to generate thermophysical properties data to the **AM Calculator**. A steady-state AM simulation is done to predict the solidification conditions in the melt pool, the solidification rates, and thermal gradients.

Then using the **Property Model Calculator** with the **Columnar to Equiaxed Transition (CET)** model, the calculated CET curves for an IN718 alloy are fed into the **AM + CET** node (the renamed Plot Renderer), where together the data from the AM and Property Model calculations are combined and overlaid on one plot.

The literature data from Polonsky et al. [2020Pol] are not purely experimental data, but rather combined with experimental equiaxed evidence and model calculations with numerical values of thermal gradients, growth velocity as well as tip undercooling. Polonsky et al. estimated tip undercooling based on a Scheil calculation, which smeared out the composition inhomogeneity at the dendrite front, hence underestimating the undercooling. Since both tip undercooling and nucleation site density promotes the formation of equiaxed crystals, an increase in undercooling in this example calculation leads to a decrease in nucleation site density compared to the results in [2020Pol] if one were fitting the same set of data.

Project File and License Information

- Folder: **Additive Manufacturing**
- File name: `AM_10_Columnar_to_Equiaxed_Transition_IN718.tcu`



A separate license is required to perform calculations with the Additive Manufacturing (AM) Module. This example also requires additional database licenses for the TCS Ni-based Superalloys Database (TCNI) (TCNI12 and newer), and the TCS Ni-alloys Mobility Database (MOBNI) (MOBNI6 and newer).

Configuration and Calculation Set Up

On the **Scheil Calculator** (renamed to *Scheil with solute trapping*), the **Scheil with solute trapping** is used with these specific settings:

- Trans-interface diffusivity: **Same for all elements**
- Prefactor: $5.0E-9$
- Maximum velocity for infinite driving force: 2000 m/s
- Model: **Aziz**
- Interface driving force: **Driving energy**

For the **AM Calculator** (renamed to *AM Steady-state*), the **Steady-state** calculation is configured as a **Gaussian Heat Source** with the **Keyhole model** and includes **Fluid flow**. It also uses a **Single Point** calculation with the **Calculated Absorptivity**.

On the **Property Model Calculator** (renamed to *Columnar to Equiaxed Transition*) a **One Axis** calculation for the **FCC_L12** primary phase is done using the CET parameters entered on the **Configuration** window.

The settings on the Property Model Calculator include:

- Interfacial energy: 0.5 J/m².
- Number of nucleation sites: $4.0E11$ /m³
- Nucleation undercooling : 4.0 K
- Equiaxed exponent: 3.13
- Solve for: **Thermal gradient**
- Equiaxed fractions: 0.01 0.49 0.99
- Solidification rate: $\log_{10}(\nu)$

Visualizations

Open the example project file to review the node setup on the **Project** window and the associated settings on the **Configuration** window for each node. For some types of projects, you can also adjust settings on the **Plot Renderer Configuration** window to preview results before performing the simulation. Click **Perform Tree** to generate plots and tables to see the results on the **Visualizations** window.



There is a wide variety of information shown both in the **Visualizations** and **Plot Renderer Configuration** windows that can be viewed during configuration and after performing the calculation(s). Not all views, such as the **Geometry** or previews, nor all additional output (i.e. plots) are shown in this section and it is recommended that you open and run the example to review all available options and results.

The thermal gradients and solidification rate can be visualized in 2D or 3D. [Figure 129](#) shows the thermal gradient along the melt pool boundary in a 3D plot. Only the data corresponding to solidification conditions are shown. The thermal gradients corresponding to melting conditions are filtered out and only the tail part of the melt pool are shown.

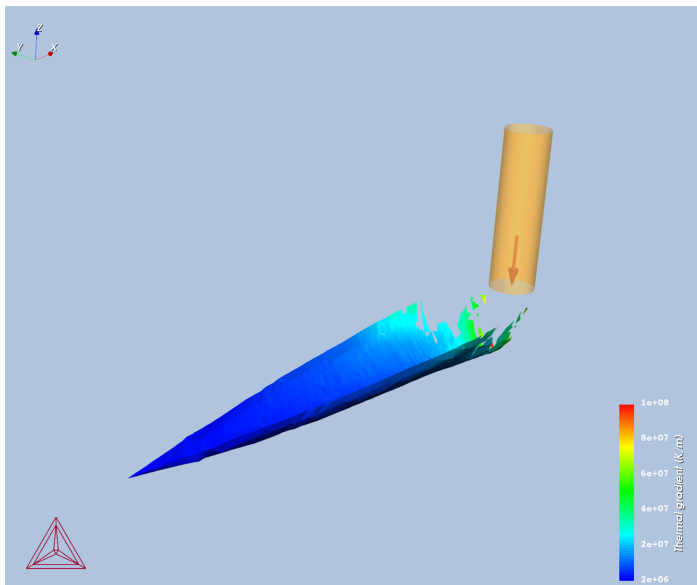

Figure 129: The 3D Plot for the 3D Thermal Gradient Plot Renderer.

Both the thermal gradients and solidification rates from the melt pool can be visualized at the same time in a 2D scatter plot when the Plot Renderer tab **Thermal Gradient vs Solidification Rate** is selected.

Visualizations			
AM Steady-state	AM Thermal Gradient & solidification rate	AM + CET	3D Thermal gradient
3D Plot	Plot Over Line	Thermal Gradient vs Solidification Rate	

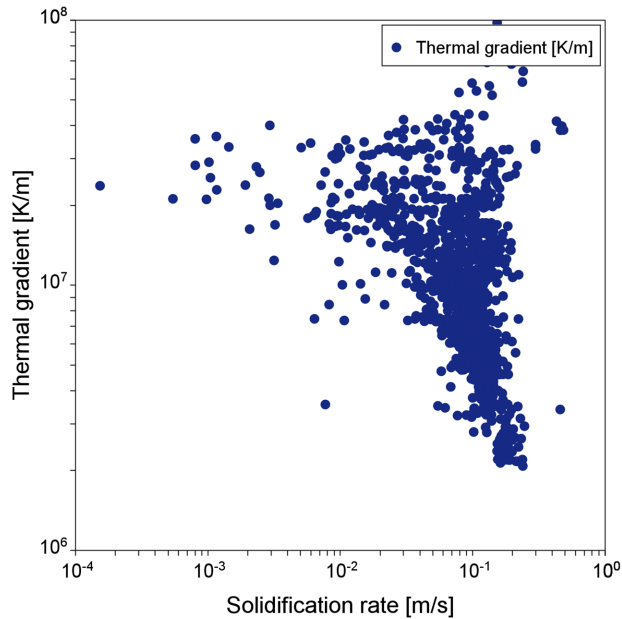

Figure 130: The solidification rate vs thermal gradient is shown on the AM Thermal Gradient & Solidification Rate Plot Renderer.

Figure 131 is an example of a plot where the results from both the AM simulation and the CET model for the IN718 thermal gradient vs solidification rate are overlaid on the same plot. The blue, red, and green lines show the increasing equiaxed fraction from the CET Property Model and the points show the solidification conditions at the melt pool calculated with the Additive Manufacturing (AM) Module. When the results are overlaid like this, you can see that nearly all the points (those below the purple line) exist in a fully columnar region.

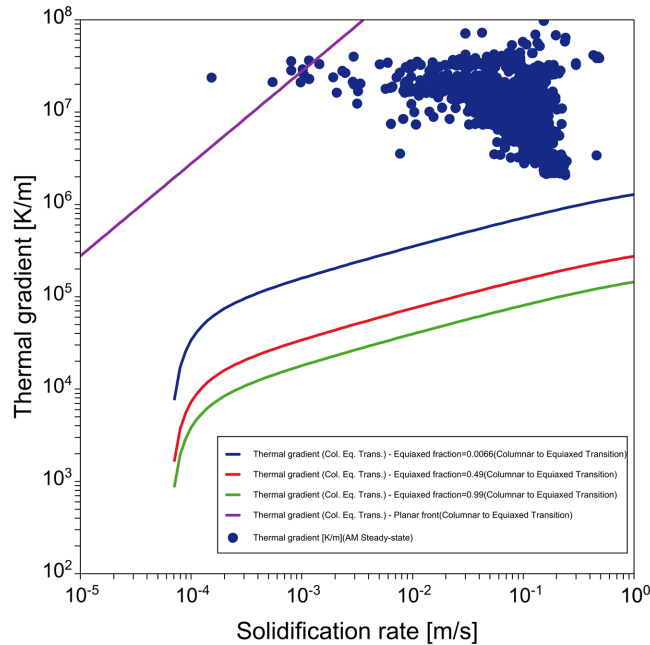

Figure 131: The solidification rate vs the thermal gradient overlaying both plots from the AM Calculator and Property Model Calculator (via the AM + CET Plot Renderer).

Reference

[2020Pol] A. T. Polonsky, N. Raghavan, M. P. Echlin, M. M. Kirka, R. R. Dehoff, T. M. Pollock, 3D Characterization of the Columnar-to-Equiaxed Transition in Additively Manufactured Inconel 718, in *Superalloys 2020* (2020), pp. 990–1002.

Other Resources



Read more about the [Additive Manufacturing \(AM\) Module](#) on our website including the details about database compatibility or to watch an [introductory webinar](#). You can also use the [Getting Started Guide](#) to learn about the key features available.



Many of our Graphical Mode examples have video tutorials, which you can access in a variety of ways. When in Thermo-Calc, from the menu select **Help** → **Video Tutorials**, or from the main My Project window, click **Video Tutorials**. Alternately, you can go to the [website](#) or our [YouTube channel](#).

AM_11: Comparing Single Tracks Printed on Casted and LPBF Substrates

Bogdonova et al. [2024Bog] performed single track experiments with the alloy Al10SiMg. The study compared the printing of single tracks on two types of substrates—one fabricated with traditional casting and the other with laser powder bed fusion (LPBF).

Project File and License Information

- Folder: **Additive Manufacturing**
- File name: `AM_11_Batch_Al10SiMg.tcu`



A separate license is required to perform calculations with the Additive Manufacturing (AM) Module. This example also requires an additional database license for the TCS AI-based Alloy Database (TCAL) (TCAL9 and newer).

Background

It is well known that the thermal conductivity of the alloy Al10SiMg is drastically reduced in the as-printed condition when fabricated by LPBF compared to conventionally manufactured counterparts [2022Gha].

Thermal conductivity in Thermo-Calc is modeled as a temperature- and composition-dependent property per phase, and the conductivity of the alloy is taken as an average over the stable phases. The composition of the primary phase can change greatly depending on the fabrication method where the LPBF method results in rapid solidification and solute trapping of solute alloy elements.

Thermal conductivity can generally be reduced by different scattering phenomena (pores, defects, phase interfaces) within the microstructure and can therefore be lower than the calculated conductivity averaged over the phases.

The electrical resistivity due to phase interface scattering is evaluated as the scattering constant times sum of the interaction between the volume fraction of all the phases. The default value for the phase interface scattering constant is found to be $4.0e-8 \Omega m$ for aluminum alloys. The contribution to thermal conductivity is assumed to be related to that of electrical resistivity, following the Wiedemann-Franz law.

The rapid solidification during LPBF generally results in a much finer microstructure compared to traditional casting. LPBF fabricated Al10SiMg solidifies with a cellular primary FCC structure and a eutectic structure between the cells [2021Lef]. An increased interface scattering constant more than $4.0E-8$ can be argued given the much finer structure that has a large number of phase interfaces.

In this example the effect on material properties and melt pool dimensions is compared when printing single tracks on the two types of substrates. The material properties for the traditionally cast alloy is calculated using regular Scheil and the default interface scattering constant of $4.0E-8$. The material properties for the LPBF fabricated alloy is calculated using Scheil with solute trapping and the effect of increasing the interface scattering is shown.

Visualizations

Open the example project file to review the node setup on the **Project** window and the associated settings on the **Configuration** window for each node. For some types of projects, you can also adjust settings on the **Plot Renderer Configuration** window to preview results before performing the simulation. Click **Perform Tree** to generate plots and tables to see the results on the **Visualizations** window.



There is a wide variety of information shown both in the **Visualizations** and **Plot Renderer Configuration** windows that can be viewed during configuration and after performing the calculation(s). Not all views, such as the **Geometry** or previews, nor all additional output (i.e. plots) are shown in this section and it is recommended that you open and run the example to review all available options and results.



When you run (Perform) this example, it can take around two hours to complete the calculations.

Material Properties for the As-cast Substrate Material

The TCS Al-based Alloy Database (TCAL) is selected on the **System Definer** (renamed to *Scheil As-cast*). The as-cast Al10SiMg alloy has the composition of Al-10.8Si-0.3Mg-0.1Cu-0.1Fe.

The **Scheil Calculator** (renamed to *Scheil As-cast*) is configured with default settings for AM with an evaluation of thermophysical properties from 5000 K down to room temperature. The **Calculation type** is set to **Classic Scheil**.

Material Properties for the LPBF Printed Substrate Material

The TCS Al-based Alloy Database (TCAL) is selected in the **System Definer** (renamed to *Scheil printed*). The LPBF Al10SiMg alloy has almost the same composition (Al-10.8Si-0.3Mg-0.1Cu-0.2Fe) with only a small difference in Fe content.

The **Scheil Calculator** (renamed to *Scheil Solute-Trapping*) is configured with the default settings for AM with an evaluation of thermophysical properties from 5000 K down to room temperature. The **Calculation type** is set to **Scheil with solute trapping**.

Comparing Material Properties Between the Substrates

Two plots overlay results from the two Scheil Calculators in [Figure 132](#). The Plot Renderer, renamed to *Si in primary FCC*, shows the Si content in the primary FCC phase. The classic Scheil calculation gives less than 1.5 at% Si. The solute trapping simulation results in twice the Si content with about 3 at% Si in the primary FCC phase. Atom probe experiments for a LPBF printed Al10SiMg alloy measured 3.08 at% Si in the FCC cell structure for the as-printed condition [2021Lef].

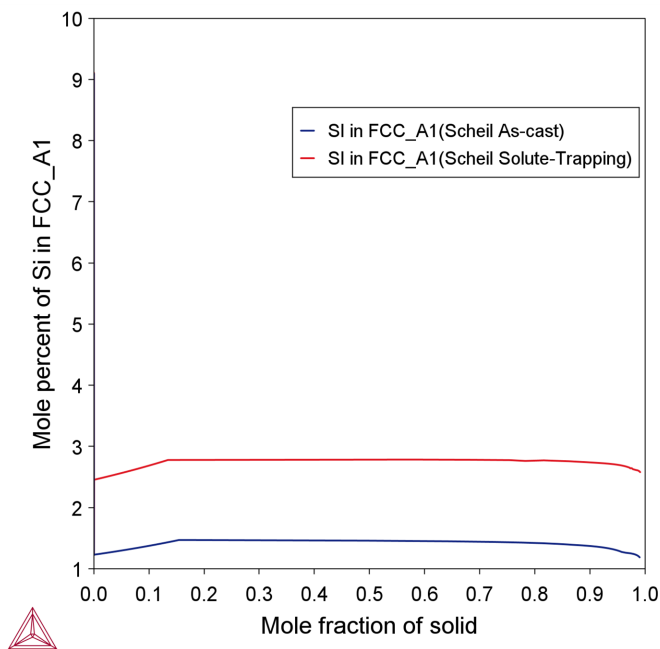

Figure 132: Silicon content in the primary FCC phase comparing regular (classic) Scheil with Scheil and solute trapping. The solute trapping almost doubles the Si content in the primary FCC phase.

[Figure 133](#) is another overlaid plot that takes the results from two Scheil Calculator predecessors to show how the thermal conductivity varies with temperature. The conductivity for the as-cast substrate (blue line), that uses classic Scheil and the default setting for the phase interface scattering constant ($C = 4.0E-8$), naturally gives the highest thermal conductivity. The red line shows the reduction in conductivity due to

solute trapping and the increased Si content in the primary phase. The green line shows further reduction in thermal conductivity due to the increased interface scattering when the scattering constant was increased ($C = 1.0E-7$).

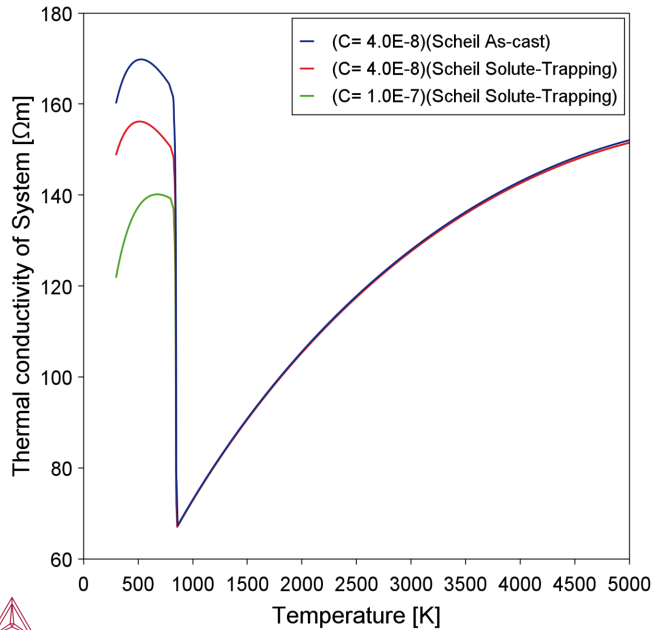

Figure 133: Thermal conductivity for as-cast substrate and printed substrate. Blue line shows conductivity for as-cast structure using the default setting for the interface scattering constant ($C = 4.0E-8$). The red line shows the reduced conductivity due to the solute trapping. Finally, the green line shows further reduction in thermal conductivity due to increased interface scattering where $C = 1.0E-7$.

Batch AM Steady-State Simulations

Two AM Calculators are next set up. These are renamed to *As-cast Batch* and *AM Batch*. These AM batch steady-state simulations are configured with similar settings, except for the interface scattering and the measured experimental melt pool dimensions that are different for the as-cast and LPBF fabricated substrates. The interface scattering settings are found on the **Material Properties** tab for both AM Calculators:

- The as-cast substrate uses the default interface scattering ($C = 4.0E-8$).
- The LPBF as-printed substrate uses the increased value for interface scattering ($C = 1.0E-7$).

The shared settings in the AM Calculator configuration (on the **Conditions** tab) are:

- Uses **Fluid flow including Marangoni effect** and the **keyhole model**.
- **Absorptivity** is selected as **Calculated** and the **with prefactor** is set to 1.8 times the calculated value in order to match the experimental melt pool dimensions.



The need to use a large prefactor is probably related to surface oxides and that the calculated absorptivity is for an oxide free liquid surface. The stable oxide Al_2O_3 often forms at the surfaces of Al-alloys where it remains in solid form to above 2000 °C and evaporates well above 3000 °C.

Configuration

As-cast Batch

Conditions Material Properties Options

Steady-state Transient Transient with heat source from Steady-state

Global Settings

Gas pressure: 100000.0 Pascal

Temperature unit: Kelvin

Base plate temperature: 303.15

Ambient temperature: 296.15

Fluid flow including Marangoni effect:

Use separate material properties for powder: Powder der

Heat Source

Gaussian Absorptivity: Calculated with prefactor 1.8 Wave length: 1064.0 nm

Beam radius: 40.0 μm

Use keyhole model Beam quality factor M^2 1.0

Figure 134: The settings window for an AM steady-state simulation for the As-cast Batch calculator. Fluid flow and Gaussian heat source with keyhole model are enabled, plus it uses a calculated absorptivity with a prefactor set to 1.8.



To reduce total calculation time, for each AM Calculator only 5 of the 12 experiments are selected on the Plot Renderer (click **Show Table** to see the details). However, the example still takes about two hours to perform.

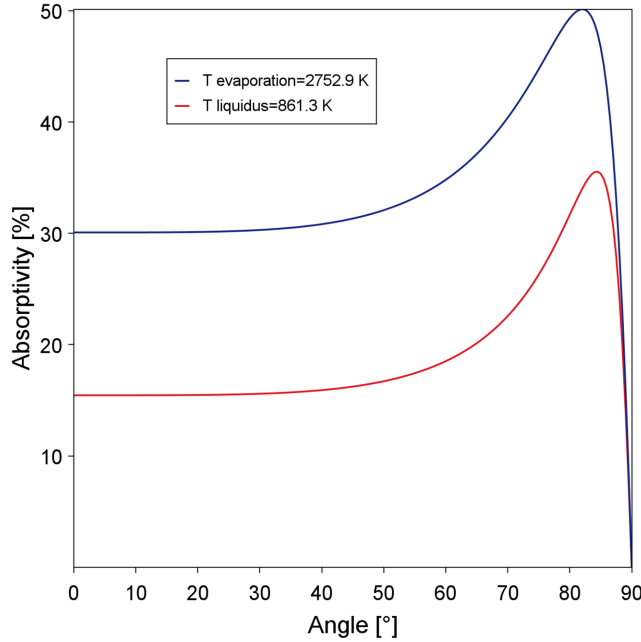

Figure 135: The temperature- and incident angle-dependent absorptivity. Red curve shows the absorptivity as a function of incident angle at the liquidus temperature, the blue curve shows the corresponding absorptivity at the evaporation temperature.

Turbulent Flow - Large Eddy Simulations

Al-alloys have in general lower viscosity compared to other metallic alloys (e.g. Ti-, Fe- or Ni-based alloys). The low viscosity in combination with high fluid flow rates can result in turbulent flows. This happens in this example for the simulations at the higher energy densities. The turbulent flow model implemented in the AM simulation is based on *Large Eddy Simulations* (LES) where the large-scale motions are represented directly and smaller-scale motions are modeled. A larger Smagorinsky constant filters more small-scale motions to be modeled. The example increases the Smagorinsky constant to 0.5. The simulations with the highest energy densities will otherwise fail to converge with the default value of 0.18.

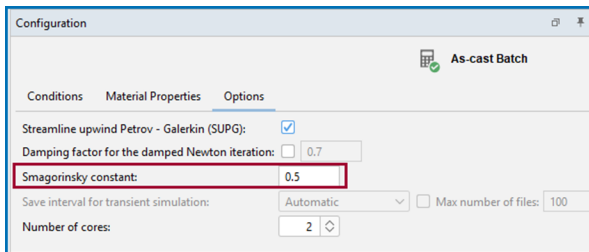

Figure 136: On the Options tab for the AM Steady-State simulation (As-cast Batch) with an increased Smagorinsky constant to handle the high turbulent flows.

The following parity plot examples compare the experimental versus calculated melt pool dimensions. In general a good trend can be seen for both the simulations with the as-cast and LPBF fabricated substrates. The experimental melt pools are in general deeper than the simulated with an increasing error with increasing depth of the melt pool.

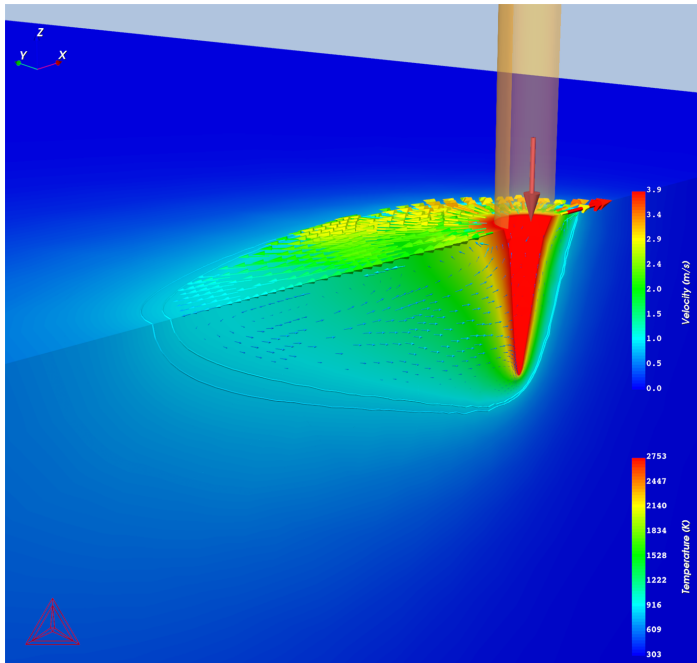

Figure 137: 3D plot of melt pool for as-cast substrate where $P = 325 \text{ W}$ and scanning speed = 600 mm/s .

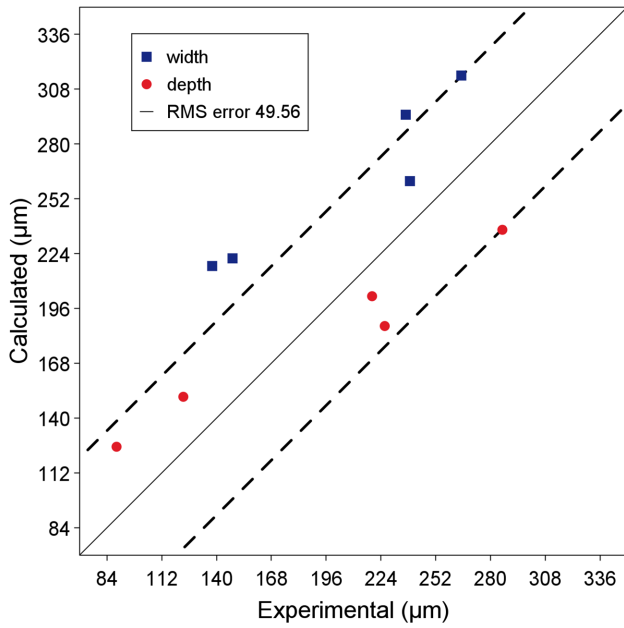

Figure 138: Parity plot for as-cast substrate when 5/12 experiments are calculated.

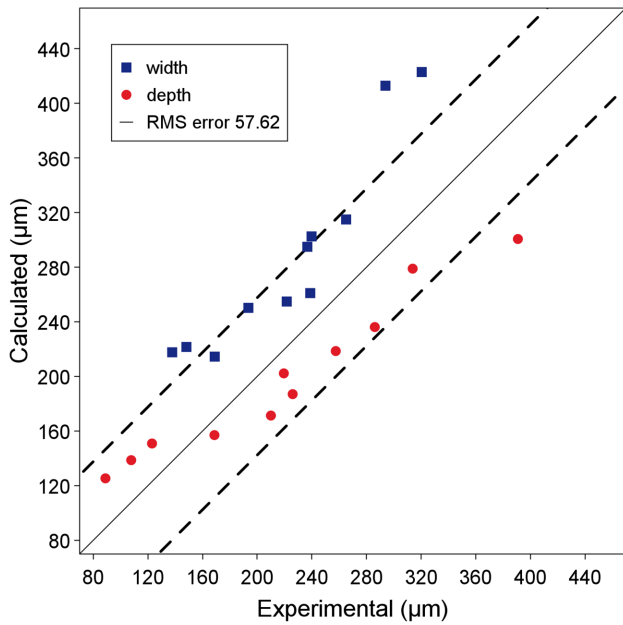

Figure 139: Parity plot for as-cast substrate when all 12 experiments are calculated.

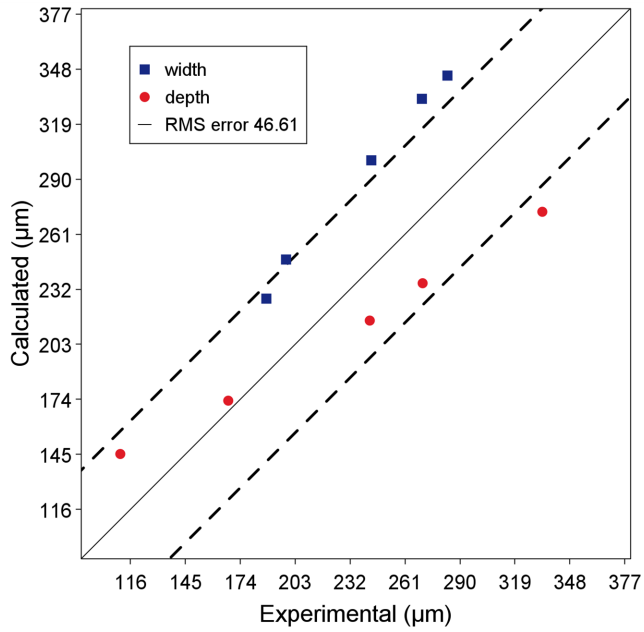

Figure 140: Parity plot for LPBF printed substrate when 5/12 experiments are calculated.

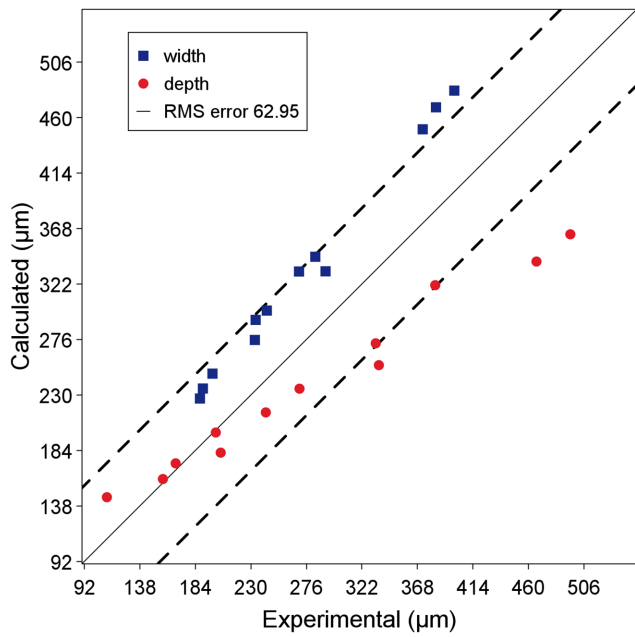

Figure 141: Parity plot for LPBF printed substrate when all 12 experiments are calculated.

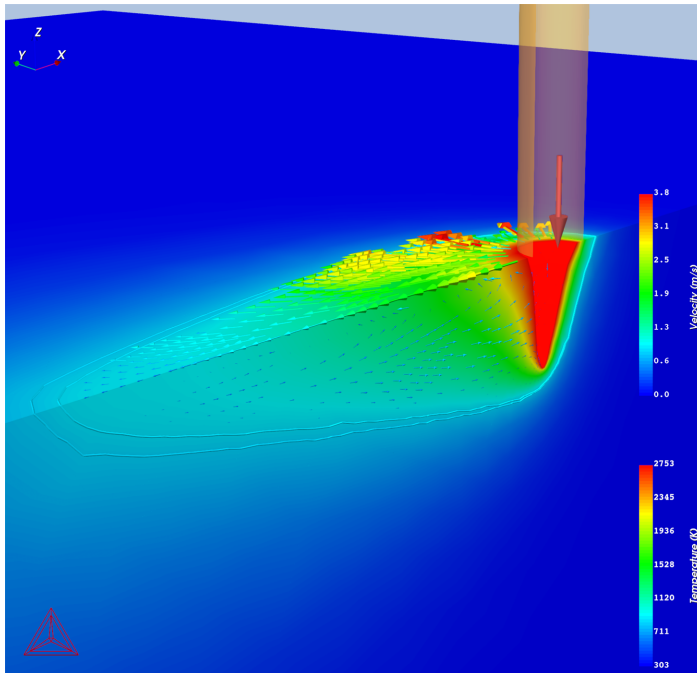

Figure 142: 3D plot of melt pool for LPBF printed substrate where $P = 325$ W and scanning speed = 1200 mm/s.

References

- [2021Lef] W. Lefebvre, G. Rose, P. Delroisse, E. Baustert, F. Cuvilly, A. Simar, Nanoscale periodic gradients generated by laser powder bed fusion of an AlSi10Mg alloy. *Mater. Des.* 197, 109264 (2021).
- [2022Gha] A. Ghasemi, E. Fereiduni, M. Balbaa, M. Elbestawi, S. Habibi, Unraveling the low thermal conductivity of the LPBF fabricated pure Al, AlSi12, and AlSi10Mg alloys through substrate preheating. *Addit. Manuf.* 59, 103148 (2022).
- [2024Bog] M. Bogdanova, S. Chernyshikhin, A. Zakirov, B. Zotov, L. Fedorenko, S. Belousov, A. Perepelkina, B. Korneev, M. Lyange, I. Pelevin, I. Iskandarova, E. Dzidziguri, B. Potapkin, A. Gromov, Mesoscale Simulation of Laser Powder Bed Fusion with an Increased Layer Thickness for AlSi10Mg Alloy. *J. Manuf. Mater. Process.* 8, 7 (2024).

Other Resources



Read more about the [Additive Manufacturing \(AM\) Module](#) on our website including the details about database compatibility or to watch an [introductory webinar](#). You can also use the [Getting Started Guide](#) to learn about the key features available.



Many of our Graphical Mode examples have video tutorials, which you can access in a variety of ways. When in Thermo-Calc, from the menu select **Help → Video Tutorials**, or from the main My Project window, click **Video Tutorials**. Alternately, you can go to the [website](#) or our [YouTube channel](#).

AM_12: Using AM Calculator Probe Data with the Precipitation Module (TC-PRISMA)

This example demonstrates the coupling of the **AM Calculator** with the **Precipitation Calculator** via probe data from an AM simulation. Both a thermodynamic and mobility database is needed for the precipitation calculation, so the AM Material Library cannot be used. Instead, a **Scheil Calculator** is used to calculate the material properties used in the AM simulation.

The example simulates the incipient melting and re-precipitation of gamma prime in CMSX-4 during Selective Electron Beam Melting (SEBM) during a single pass of the beam. The SEBM process is simulated using an Electron Beam heat source. A transient with heat source from Steady-state simulation of a single track is simulated, with a cooling time of 150 s. The bed and ambient temperature is elevated to 950 °C. The process parameters are taken from Ramsperger et al. [2016aRam].

Project File and License Information

- Folder: **Additive Manufacturing**
- File name: *AM_12_AM_Probe_to_Precipitation.tcu*



A separate license is required to perform calculations with the Additive Manufacturing (AM) Module. This example also requires a license for the Precipitation Module (TC-PRISMA), plus additional database licenses for the TCS Ni-based Superalloys Database (TCNI) (TCNI13 and newer is recommended for best results), and the TCS Ni-alloys Mobility Database (MOBNI) (MOBNI6 and newer).

Background

Ramsperger and Körner [2016bRam] demonstrated that it is possible to print single crystal CMSX-4 components using SLBM with an elevated bed temperature. The main challenge encountered is fracture during printing. The formation of gamma prime may incur a drop in ductility that contributes to fracture. Understanding the precipitation kinetics of gamma prime during 3D printing is important with regards to identifying optimum process parameters, and determining how best to heat treat the final component.

Wahlmann et al. [2019Wah] studied gamma prime kinetics in emulated SLBM thermal conditions, indirectly measuring the size of the gamma prime using X-ray diffraction during repeated nucleation and dissolution thermal cycles imitating the thermal history of an SLBM build. [Figure 143](#) shows the calibration of the Precipitation Calculator to capture the measured kinetics.

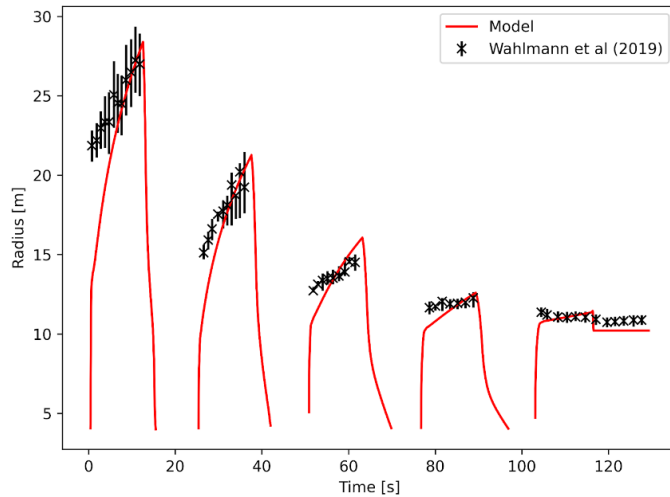

Figure 143: A comparison of the indirectly measured gamma prime size evolution during thermal heat treatment emulated an SLBM process with predictions from the Precipitation Calculator using the Thermo-Calc Ni-based superalloys databases (TCNI12 and MOBNI6) [2019Wah].

This AM Calculator to Precipitation Calculator example uses the calibrated parameters for gamma prime kinetics shown in Figure 143. The Precipitation Calculator includes the possibility for incipient melting of the gamma prime, which is predicted to occur during the first pass of the electron beam. Incipient melting describes the phenomena where solid-state precipitates are heated rapidly to a high temperature beyond their solvus temperature. The precipitates reach a temperature where they melt before the parent matrix phase. The Precipitation Calculator removes the gamma prime dispersion upon melting.

Configuration and Calculation Set Up

The **Additive Manufacturing** template was used to first add the **System Definer**, **Scheil Calculator**, **AM Calculator**, and **Plot Renderer** to the **Project** window tree. Additionally, a **Precipitation Calculator** was added as a successor to the AM Calculator in order to automatically import the time-temperature profile from the AM simulation into the precipitation simulation.



Open the example to see the **Project** tree layout and review the settings for each activity. It is useful to click around in the interface to understand where the settings are located and configured. This section highlights the relevant settings for this example.

System Definer

On the **System Definer**, the nickel-based superalloy CSMX-4 composition was approximated by Ni-9.8Co-6.4Ta-6.5Cr-6.4W-5.7Al-2.8Re-0.97Ti-0.62Mo-0.086Hf, (mass%). The thermodynamic (TCNI) and mobility (MOBNI) nickel-based superalloy databases were selected, with the phase **DIS_FCC_A1** included.



You can include or exclude phases from the **Phases and Phase Constitution** tab on the System Definer.

AM Calculator

On the **AM Calculator Configuration** window, the calculation type **Transient with heat source from Steady-state** is selected with a single track scan pattern and **Geometry** of 5 mm x 5 mm x 5 mm (height x width x length). The **Base plate temperature** and **Ambient temperature** is set to 950 °C with a gas pressure of 1 Pa.

Additional settings are then made on the **Configuration** window as follows.

- In the *Heat Source* section, **Electron Beam** is selected with a **Power** of 1110 W, a **Calculated Absorptivity**, an **Acceleration voltage** of 60 kV, and a **Beam radius** of 250 µm. The **keyhole model** checkbox is selected.
- In the *Scanning Strategy* section, the **Scanning speed** is 2000 mm/s and the **Layer thickness** is 50 µm. A **Cooling time** of 150 s is included.
- In the *Top Boundary Conditions* section, the **Evaporation** checkbox is selected to include this in the model.
- In the *Probe Positions* section, a single probe is added to the center of the top surface of the component, below the powder layer. See the **Geometry** tab as shown in [Figure 144](#).

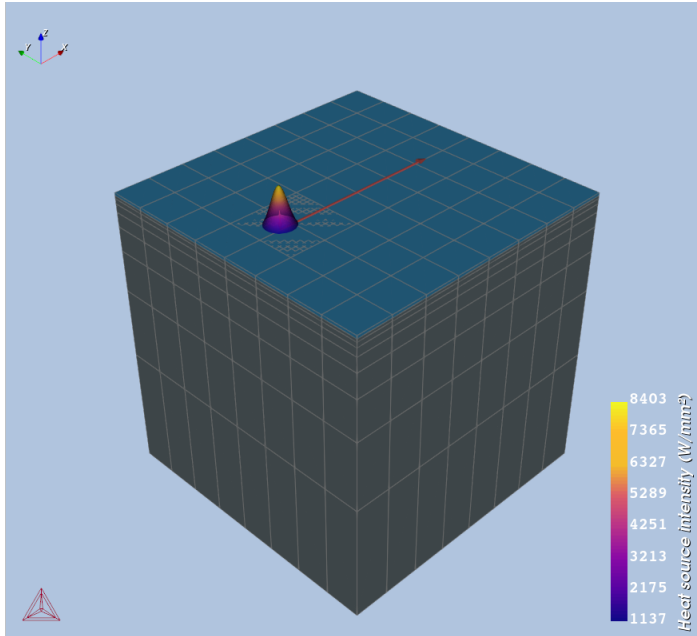

Figure 144: The full geometry set up for the single track AM simulation with a probe point added to the middle of the scan. Open the example to better see the set up and try working in the Visualizations window.

Precipitation Calculator

The following highlights the relevant settings to make on the **Configuration** window for this example.

On the **Options** tab:

- Both the **Preprocess equilibrium data** and **Include incipient melting** checkboxes are selected.

On the **Conditions** tab, under *Matrix Phase*:

- **DIS_FCC_A1** is selected.



Also see "Selecting the Disordered Phase as a Matrix Phase" in the *Precipitation Module User Guide*, or search for this in the help.

- Click **Show Details**, then for **Mobility adjustment > Prefactor**, keep **Same for all elements** and enter **6.0** for the **Prefactor**.

On the **Conditions** tab, under *Precipitate Phase*:

- **FCC_L12#2** is selected.
- **Nucleation sites = Bulk**
- **Interfacial energy = 0.035 J/m²**

- Click **Show Details**, then:
 - **Phase energy addition** = -55.0 J/mol
 - Select the **Preexisting size distribution** checkbox.
 - Click **Edit Particle Size Distribution**, and note the *Compositions* entered.

Dependent component:	Ni	Mass percent
Al	7.585	
Co	5.382	
Cr	2.6	
Hf	0.135	
Mo	0.288	
Re	0.394	
Ta	9.568	
Ti	1.455	
W	4.525	



In the **Preexisting Particle Size Distribution** window you can also adjust other settings. In this case, the size distribution is approximated by a Weibull distribution function with a mean radius of 200 nm, an Alpha of 2.0, and a fraction offset of 0.5 Search for "Particle Size Distribution (PSD)" in the *Precipitation Module User Guide*, or in the help.

On the **Conditions** tab, under *Calculation Type*:

- **Temperature unit** = Kelvin
- **Start time** = 0.0
- **Simulation time** = 150.01 **Seconds**
- **Probes**: Probe1
- **Condense time-temperature data** = None

Visualizations



Many of our Graphical Mode examples have video tutorials, which you can access in a variety of ways. When in Thermo-Calc, from the menu select **Help** → **Video Tutorials**, or from the main My Project window, click **Video Tutorials**. Alternately, you can go to the [website](#) or our [YouTube channel](#).

Open the example project file to review the node setup on the **Project** window and the associated settings on the **Configuration** window for each node. For some types of projects, you can also adjust settings on the **Plot Renderer Configuration** window to preview results before performing the simulation. Click **Perform Tree** to generate plots and tables to see the results on the **Visualizations** window.

There is a variety of information shown in the **Visualizations** window that can be viewed during configuration and after performing the calculation(s).

Figure 145 and Figure 146 show the predicted evolution of the precipitate dispersion including the change in mean radius and volume fraction, respectively. The second Y axis in both figures shows the temperature. The initial gamma prime size distribution describes the gamma prime that has formed during the production of the AM powder. It is too large to dissolve during the rapid heating as the electron beam heats the component, and melts before the matrix. The gamma prime re-precipitates upon resolidification and cooling below the gamma prime solvus, and coarsens whilst held at elevated temperature. The incipient melting of the initial size distribution is clearly evident.

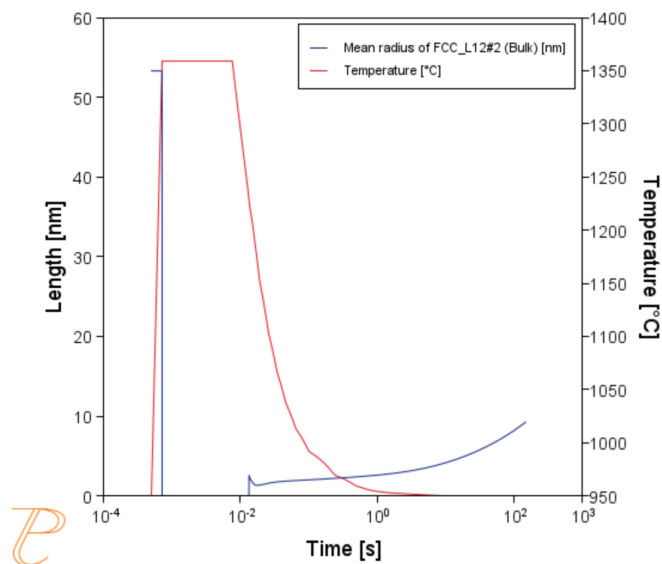

Figure 145: The mean radius and temperature as a function of time, with the mean radius on the left axis, and the temperature on the right axis.

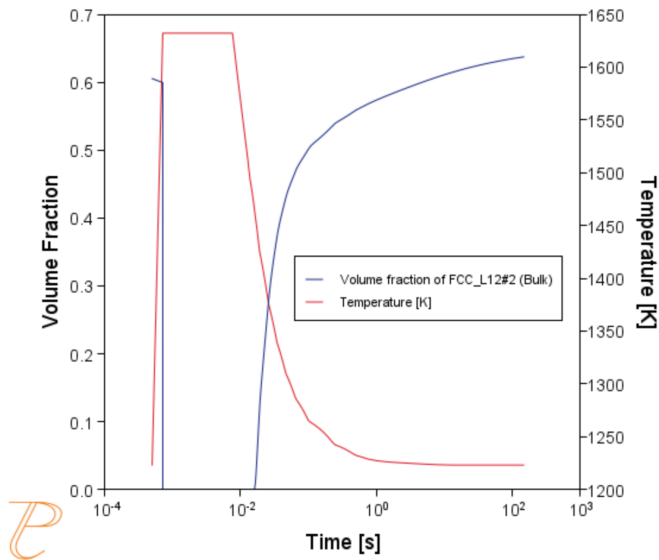

Figure 146: The volume fraction and temperature as a function of temperature, with the volume fraction on the left axis, and the temperature on the right axis.

The gamma prime distribution just prior to incipient melting is observed at 0.004 s. It has not dissolved significantly during the rapid heating as the electron beam passes. At 1 s the material has solidified and cooled to a temperature where gamma prime has nucleated and grown. The size distribution at the end of the simulation is shown at 150.1 s. Figure 147 shows the size distributions at these times during the single track AM simulation.

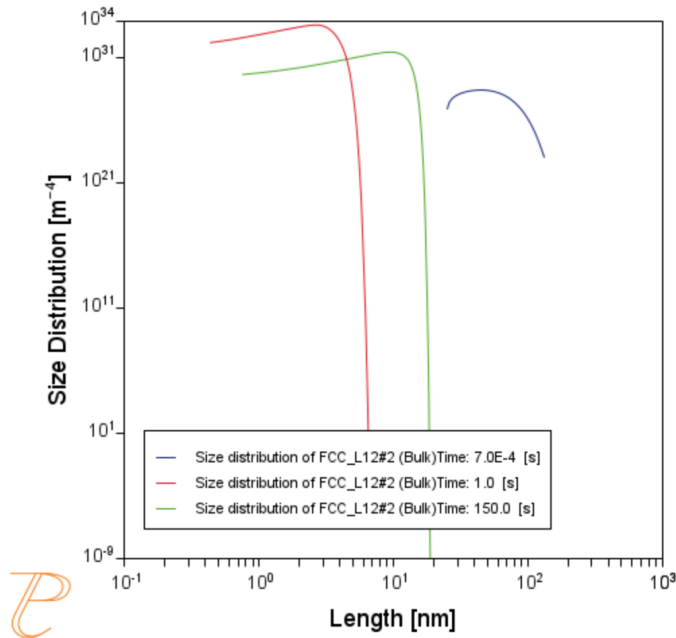

Figure 147: The size distributions of gamma prime at key points during the simulation.

References

- [2016aRam] M. Ramsperger, R. F. Singer, C. Körner, Microstructure of the Nickel-Base Superalloy CMSX-4 Fabricated by Selective Electron Beam Melting. *Metall. Mater. Trans. A* 47, 1469–1480 (2016).
- [2016bRam] M. Ramsperger, C. Körner, “Selective Electron Beam Melting of the Single Crystalline Nickel-Base Superalloy CMSX-4®: From Columnar Grains to a Single Crystal” in *Superalloys 2016* (John Wiley & Sons, Inc., Hoboken, NJ, USA, 2016), pp. 341–349.
- [2019Wah] B. Wahlmann, F. Galgon, A. Stark, S. Gayer, N. Schell, P. Staron, C. Körner, Growth and coarsening kinetics of gamma prime precipitates in CMSX-4 under simulated additive manufacturing conditions. *Acta Mater.* 180, 84–96 (2019).

Other Resources



Read more about the [Additive Manufacturing \(AM\) Module](#) on our website including the details about database compatibility or to watch an [introductory webinar](#). You can also use the [Getting Started Guide](#) to learn about the key features available.

AM_13: Using the Core-ring Beam Shape

This **Steady-state** example demonstrates the use of **Core-ring Heat Source** model available in the AM Module with **Batch** calculations.

The heat source parameters for the **Core-ring** heat source, as well as the processing parameters (power and speed), are taken from Holla et al. [2024Hol]. The example also compares the predicted melt pool dimensions with the experimental data from this paper.



For TC-Python users, there is an example using **Core-ring**: `pyex_AM_09_CoreRing_BeamShape.py`.



There is a companion example in Graphical Mode using **Top-hat**: "[AM_14: Using the Top-hat Beam Shape](#)" on page 221.

Project File and License Information

- Folder: **Additive Manufacturing**
- File name: `AM_13_CoreRing_BeamShape.tcu`



This example requires an Additive Manufacturing (AM) Module license.

Background

In a core-ring heat source, the energy is distributed between the central core and the surrounding ring, allowing for more precise control of heat input and a more uniform temperature distribution, reducing the risk of unstable keyhole formation [2023Bi]. Furthermore, a wider melt pool with the **Core-ring** beam shape as compared to a Gaussian profile allows enlargement of the hatch distances and together with the possibility of using higher scanning speeds, results in faster printing process and increased productivity [2021Grü].

The inclusion of a **Core-ring** heat source model in the AM Module, together with the keyhole model, allows you to predict the temperature evolution and melt pool shape along with the transition from conduction mode to keyhole mode for a **Core-ring** heat source. The experimental data taken from the literature [2024Hol] demonstrates the use of a **Core-ring** heat source for single track experiments on stainless steel

316L bare plates. A wide range of process parameters (power = 200 W – 900 W and scanning speed = 200 mm/s – 800 mm/s) also shows different cases for both conduction as well as the keyhole mode, which are correctly predicted in this example by the simulation results.

Material Properties

- SS316L: Fe-17.0Cr-12.0Ni-2.5Mo-0.03C Mass percent
- Database: TCFE13 and with interface scattering = 1e-07.
- The material properties are precalculated, and stored as a built-in material library with the Additive Manufacturing (AM) Module.

AM Calculator Configuration Settings

This example contains one AM Calculator, which is renamed to **Core-ring_20/80**. On the **Configuration** window, **Conditions** tab, this **Steady-state** calculation is configured with the **Core-ring Heat Source** with the **Keyhole model** and includes **Fluid flow**.

The **Custom Mode** is used in order to set all the heat source parameters as given in Table 2 of [2024Hol]. Individual settings are entered to match:

- **Beam radius-Core:** 47.6 μm
- **Beam radius-Ring:** 25.29 μm
- **Ring radius:** 68.4 μm

The **Amount of power in the ring** is set to **80%**, which is equivalent to 20/80 beam shape in [2024Hol].

The **Absorptivity** is set to **Calculated** with a **prefactor** of 1.2. It uses the **keyhole model** where the **Beam quality factor M^2** is kept as 1.0.

The **Batch Calculation Type** is used to set up all the conditions from the experiments in a single calculation. In the **Batch Experiment Data** section, the experimental **Power** and scan **Speed** as well as the measured melt pool Width (**Exp width**) and Depth (**Exp. depth**) were collected in a CSV file and imported into the software. This data is then saved in the project file.

In the **Batch Experiment Data** table, the **Power** ranges between 200 W to 900 W, and the scan **Speed** ranges between 200 mm/s to 800 mm/s.

Visualizations

Open the example project file to review the node setup on the **Project** window and the associated settings on the **Configuration** window for each node. For some types of projects, you can also adjust settings on the **Plot Renderer Configuration** window to preview results before performing the simulation. Click **Perform**

Tree to generate plots and tables to see the results on the **Visualizations** window.



When you run (Perform) this example, it takes a few minutes for the calculations to complete.

Parity Plot

This specific **Parity** plot is shown by clicking the **Parity Plot** node in the **Project** window. Then you can see on the **Visualizations** window it is in the tab of the same name. The settings are located on the **Configuration** window on the **Batch** tab.

The plot compares experimental and calculated melt pool width and depth for all experiments. The experiments are single tracks on bare plate SS316L with varied power and scan speed using a **Core-ring** heat source.

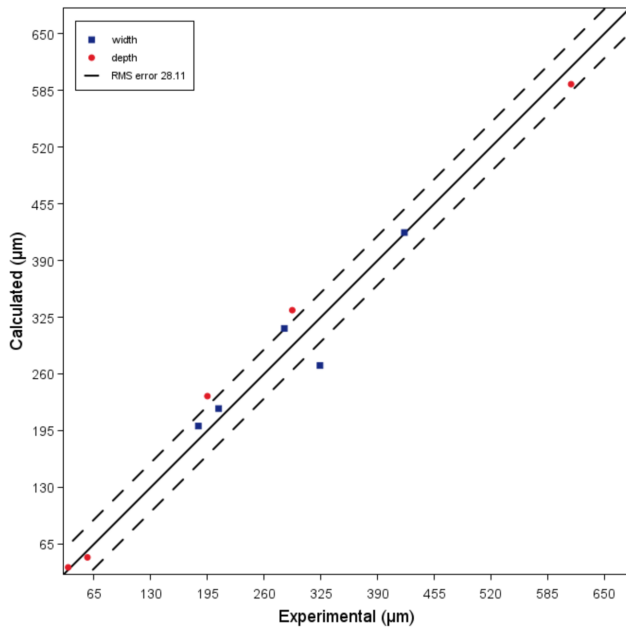

Figure 148: Parity plot comparing experimental and calculated melt pool width and depth for all the experiments when using a Core-ring heat source. The Root Mean Square (RMS) error can also be seen as a dashed line.

3D Plots

The specific **3D Plot** that is highlighted in this section is shown by clicking the **3D Plot** node in the **Project** window. Then on the **Visualizations** window on the tab of the same name, you can use various toolbar buttons to navigate and experiment with the views, for example:



Zoom to Heat Source position

In Figure 149, and using a combination of the **Plot Renderer Configuration** window settings on the **3D Plot** tab and the **Visualizations** window, different zoom levels and adjusting the **Glyph scale factor** setting helps to clearly show the melt pool and velocity vectors.

Further, the plot on the left is displayed by choosing the applicable **Batch experiments** results from the list (P=200 W, V=500 mm/s) and this set of experiments undergoes melting in conduction mode. Then the plot on the right is displayed by choosing the applicable **Batch experiments** results (P=600 W, V=200 mm/s) and that one forms a keyhole.

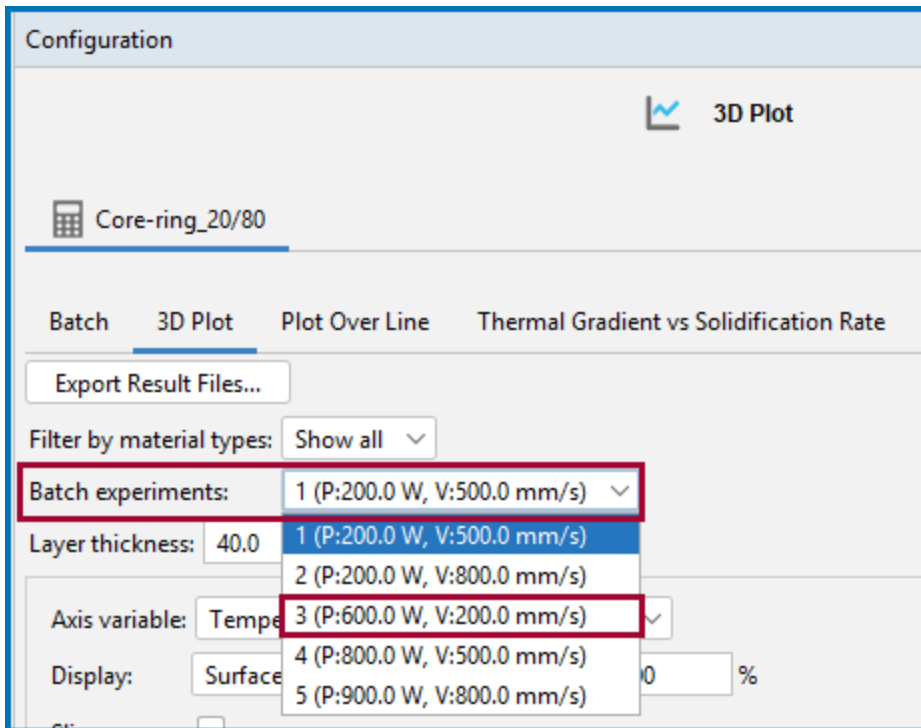

Configuration

3D Plot

Core-ring_20/80

Batch 3D Plot Plot Over Line Thermal Gradient vs Solidification Rate

Export Result Files...

Filter by material types: Show all

Batch experiments: 1 (P:200.0 W, V:500.0 mm/s) ▾

Layer thickness: 40.0 1 (P:200.0 W, V:500.0 mm/s)

2 (P:200.0 W, V:800.0 mm/s)

Axis variable: Temperature 3 (P:600.0 W, V:200.0 mm/s) ▾

Display: Surface 4 (P:800.0 W, V:500.0 mm/s)

5 (P:900.0 W, V:800.0 mm/s)

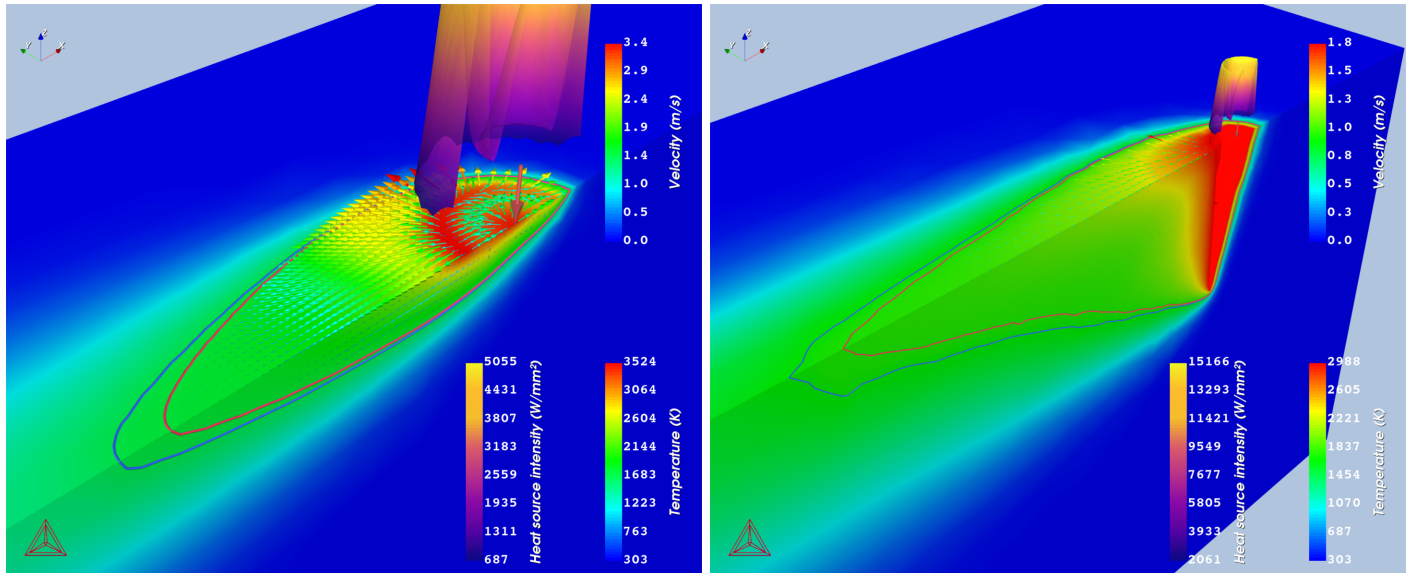

Figure 149: A comparison of the melt pools for two different processing conditions: Red and blue isocontours show liquidus and solidus temperatures, respectively. See the text for details.

In Figure 150 you can click the  **Set View** button plus  **Mirror Geometry** button to obtain this top view of a **Surface colormap**.

In general, you can play around with the **3D Plot Configuration** window settings. For example, for the right-hand side figure, you can view the **Flow velocity field** with different **Display** types such as an **Arrow** (shown).

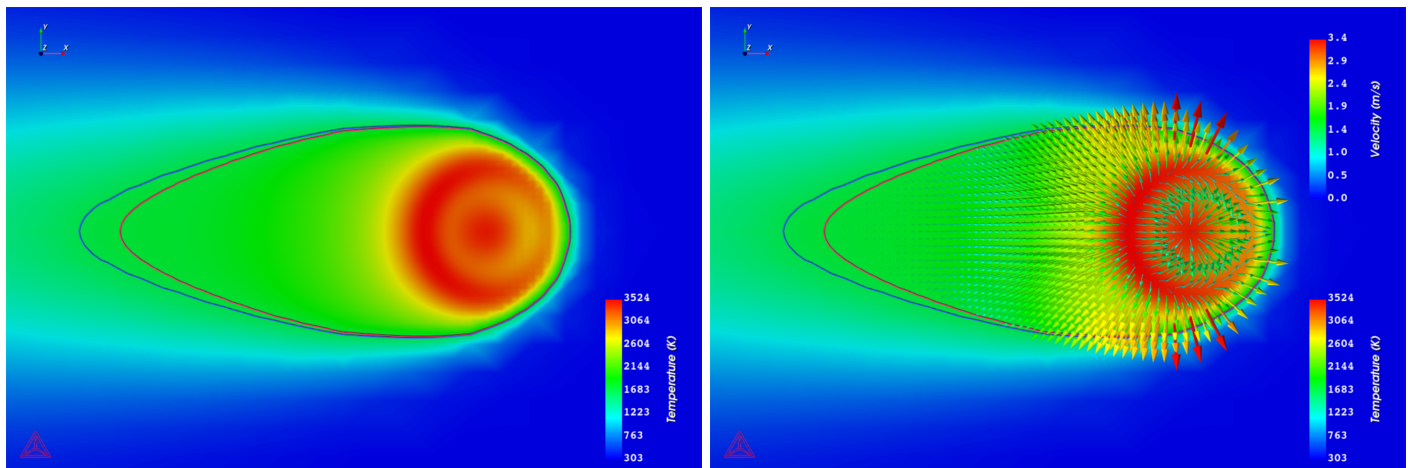

Figure 150: Top view (XY) of the surface colormap showing (left) temperature distribution due to the 20/80 Core-ring beam shape, and (right) velocity field caused by the distinctive temperature profile, resulting in widening of the melt pool. $P=200\text{ W}$, $V=500\text{ mm/s}$. Red and blue isocontours show liquidus and solidus temperatures, respectively.

In Figure 151, this cross-section compares the melt pool shape and size for **Batch experiment 1** ($P=200\text{ W}$, $V=500\text{ mm/s}$) to the experimental results as shown in Figure 9 in the paper by [2024Hol].

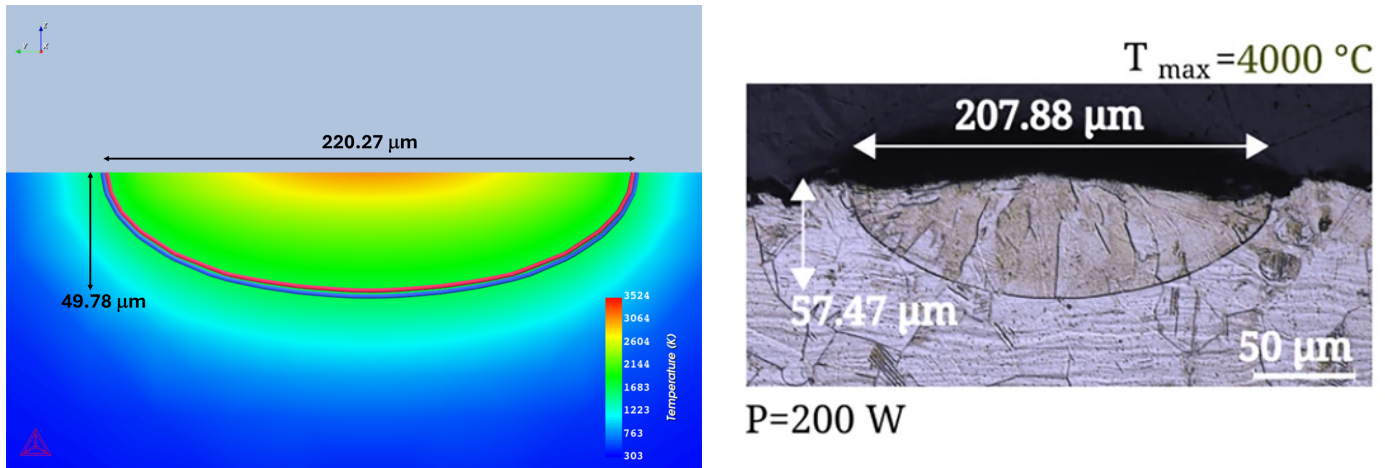

Figure 151: A cross-section comparing melt pool shape and size for $P=200\text{ W}$, $V=500\text{ mm/s}$ from (left) simulation and (right) experiments [2024Hol-Fig9]. Red and blue isocontours in the simulation result show liquidus and solidus temperatures, respectively.

In Figure 152, the formation of the melt pool is shown on the left and compared to a cross-section that is taken from **Batch experiment 3** ($P=600\text{ W}$, $V=200\text{ mm/s}$) to show the formation of a keyhole and the maximum melt pool size, where you can also see the widening of the melt pool due to fluid flow. Compare this to Figure 153, which are the experimental results as shown in Figure 9 in the paper by [2024Hol].

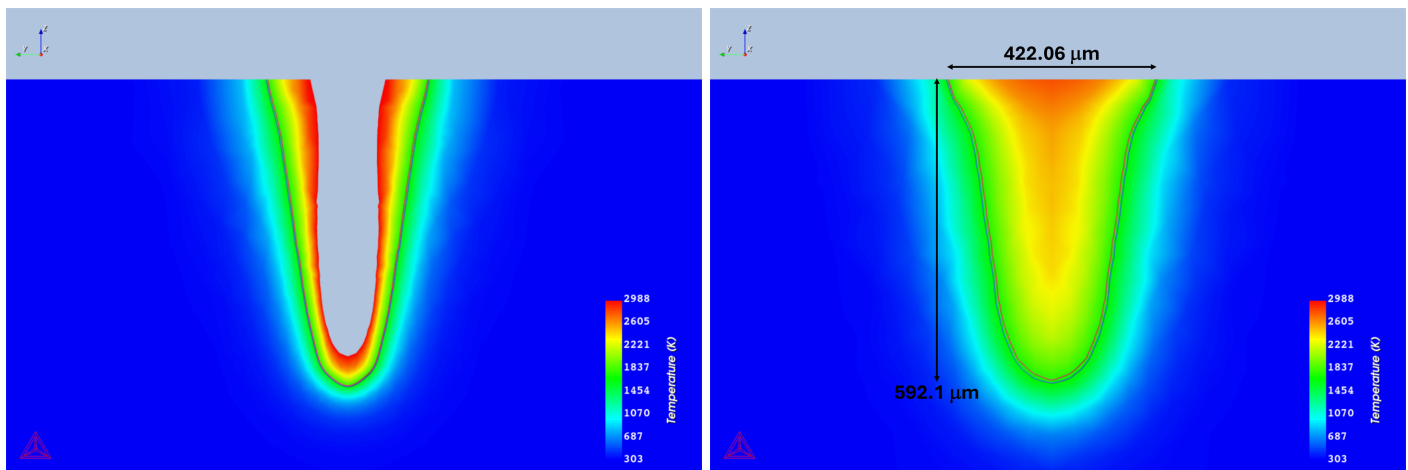

Figure 152: Cross-sections at different locations along the scanning direction showing (left) formation of keyhole and (right) maximum melt pool dimensions for $P=600\text{ W}$, $V=200\text{ mm/s}$. See the text for more.



Figure 153: Cross-section showing the experimental melt track for the same processing conditions shown in Figure 152. From [2024Hol-Fig9].

Other Resources



Read more about the [Additive Manufacturing \(AM\) Module](#) on our website including the details about database compatibility or to watch an [introductory webinar](#). You can also use the [Getting Started Guide](#) to learn about the key features available.



Many of our Graphical Mode examples have video tutorials, which you can access in a variety of ways. When in Thermo-Calc, from the menu select **Help** → **Video Tutorials**, or from the main My Project window, click **Video Tutorials**. Alternately, you can go to the [website](#) or our [YouTube channel](#).

References

- [2021Grü] J. Grünewald, F. Gehringer, M. Schmöller, K. Wudy, Influence of Ring-Shaped Beam Profiles on Process Stability and Productivity in Laser-Based Powder Bed Fusion of AISI 316L. *Metals (Basel)*. 11, 1989 (2021).
- [2023Bi] J. Bi, L. Wu, S. Li, Z. Yang, X. Jia, M. D. Starostenkov, G. Dong, Beam shaping technology and its application in metal laser additive manufacturing: A review. *J. Mater. Res. Technol.* 26, 4606–4628 (2023).
- [2024Hol] V. Holla, J. Grünewald, P. Kopp, P. M. Praegla, C. Meier, K. Wudy, S. Kollmannsberger, Validity of Thermal Simulation Models for Different Laser Beam Shapes in Bead-on-Plate Melting. *Integr. Mater. Manuf. Innov.* 13, 969–985 (2024).
- [2024Hol-Fig9]: V. Holla et. al, Validity of Thermal Simulation Models for Different Laser Beam Shapes in Bead-on-Plate Melting. *Integr. Mater. Manuf. Innov.* 13, 969–985 (2024). Creative Commons Attribution [4.0 International License](https://creativecommons.org/licenses/by/4.0/), Figure 9, accessed May 2025, cropped individual images from source. <https://link.springer.com/article/10.1007/s40192-024-00382-2/figures/9>
-

AM_14: Using the Top-hat Beam Shape

This **Steady-state** example demonstrates the use of **Top-hat Heat Source** model in the AM Module with **Batch** calculations.

The processing parameters (power and speed) and other processing conditions such as the layer thickness are taken from Sow et al. [2020Sow]. The example also compares the predicted melt pool dimensions with the experimental data.



For TC-Python users, there is an example using **Top-hat**: `pyx_AM_10_TopHat_BeamShape.py`.



There is a companion example in Graphical Mode using **Core-ring**: "[AM_13: Using the Core-ring Beam Shape](#)" on page 213.

Project File and License Information

- Folder: **Additive Manufacturing**
- File name: `AM_14_TopHat_BeamShape.tcu`



This example requires an Additive Manufacturing (AM) Module license.

Background

The primary benefit of the Top-hat heat source beam shape, in comparison to the Gaussian beam shape, is uniform energy distribution across the beam spot, leading to even heating of the material surface. With lower peak intensity as compared to the Gaussian beam, a Top-hat beam also allows the use of larger beam size that not only increases productivity but also reduces vapor-induced instabilities [2020Sow]. The inclusion of Top-hat heat source model in the AM Module, together with the keyhole model, allows you to predict the temperature evolution and melt pool shape along with the transition from conduction mode to keyhole mode for a Top-hat heat source. The example uses experimental data taken from the literature [2020Sow] and demonstrates the use of Top-hat heat source with a rather large beam size for single track experiments on an IN625 alloy.

Material Properties

- IN625: Ni-21.5Cr-5.0Fe-0.5Si-0.5Mn-9.0Mo-0.4Ti-1.0Co-1.8Nb-1.8Ta-0.4Al Mass percent
- Database: TCNI12 and with solute trapping and interface scattering = 1e-07.
- The material properties are precalculated, and stored as a built-in material library with the Additive Manufacturing (AM) Module.

AM Calculator Configuration Settings

This example contains one AM Calculator, which is renamed to **Top-hat**. On the **Configuration** window, **Conditions** tab, this **Steady-state** calculation is configured with the **Top-hat Heat Source** with the **Keyhole model**.



Fluid flow is not used in this example (the **Fluid flow including Marangoni effect** checkbox is not selected). Although fluid flow plays a crucial role in determining the shape and size of the melt pool, in this case it was found that it overestimates the melt pool width for most cases when fluid flow is included.

In the *Geometry* section, the **Height** of the base plate is set to 3.0 mm and in the *Scanning Strategy* section the **Layer thickness** is changed to 50.0 μm .

In the *Heat Source* section, the **Beam radius** is set to 450 μm .



In the [2020Sow] paper, it is mentioned that the beam diameter for the top-hat distribution is 500 μm . However, in Figure 2 of this paper, where intensity is plotted against the distance for the top-hat beam, the actual diameter looks much larger than that. In order to match the intensity distribution, the beam radius is therefore set to 450 μm .

Also in the *Heat Source* section, the **Absorptivity** is set to **Calculated** with a **prefactor** of 1.0 and in the keyhole model, **Beam quality factor M^2** is kept as 1.0.

The **Batch Calculation Type** is used to set up all the conditions from the experiments in a single calculation. In the *Batch Experiment Data* section, the experimental **Power** and scan **Speed** as well as the measured melt pool Width (**Exp width**) and Depth (**Exp. depth**) were collected in a CSV file and imported into the software. This data is then saved in the project file.

Data with the error bars is also read and stored in the project file, that is later used to plot error bars together with the experimental values of melt pool width and depth.

In the *Batch Experiment Data* table, the **Power** is always 1000 W and the scan **Speed** ranges between 25 mm/s to 500 mm/s.

Visualizations

Open the example project file to review the node setup on the **Project** window and the associated settings on the **Configuration** window for each node. For some types of projects, you can also adjust settings on the **Plot Renderer Configuration** window to preview results before performing the simulation. Click **Perform Tree** to generate plots and tables to see the results on the **Visualizations** window.



When you run (Perform) this example, it takes a few minutes for the calculations to complete.

Parity Plot

This specific **Parity** plot is shown by clicking the **Parity Plot** node in the **Project** window. Then you can see on the **Visualizations** window it is in the tab of the same name. The settings are located on the **Configuration** window on the **Batch** tab.

The plot compares experimental and calculated melt pool width and depth. It can be seen that the calculated melt pool width shows a fairly good agreement with the measured values. A mixed trend is however, seen for the melt pool depth. For lower energy densities, the calculated and measured melt pool depth matches quite well, however it starts to deviate once the melting appears to happen in the keyhole mode in the experiments, while it is still in the conduction mode in the calculations. For the last three points, where the calculations also predict a keyhole mode, the melt pool depth matches quite well with the measured value, except for the very last point where it is somehow overpredicted. The difference in depth could be attributed to the uncertainty in the actual beam size of the top-hat beam.

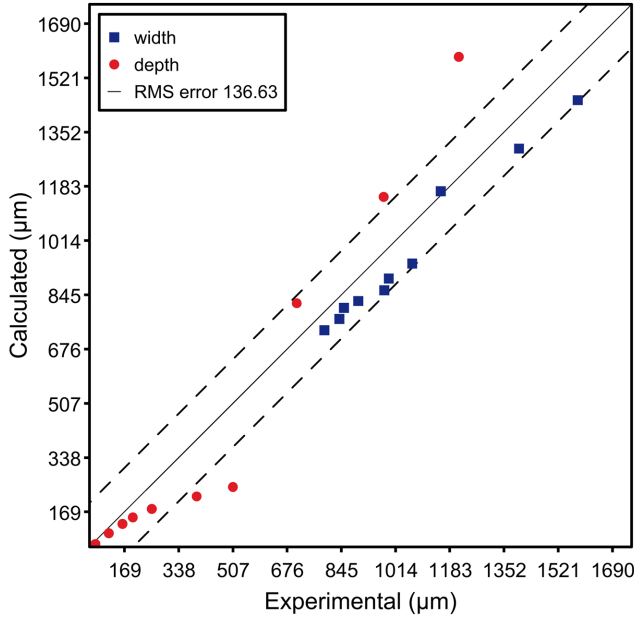

Figure 154: Parity plot comparing experimental and calculated melt pool width and depth for all the experiments. The experiments are single tracks on IN625 with constant power and varied scan speed using the Top-hat heat source. The Root Mean Square (RMS) error can also be seen as a dashed line.

Melt Pool Dimensions

This **Melt Pool vs Energy Density** plot is shown by clicking the **Melt Pool Dimensions** node in the **Project** window. Then you can see on the **Visualizations** window it is in the tab of the same name. The settings are located on the **Configuration** window on the **Batch** tab.

The plot shows a comparison of the experimental and calculated melt pool width and depth, where the error bars are also plotted with the measured data. Rather large error bars, especially for the higher energy density cases, show that the overall trend for the calculated values of melt pool width and depth is in good agreement with the measured values. Some improvements are however needed for the low energy density cases where a huge deviation is found between the calculated and measured values.

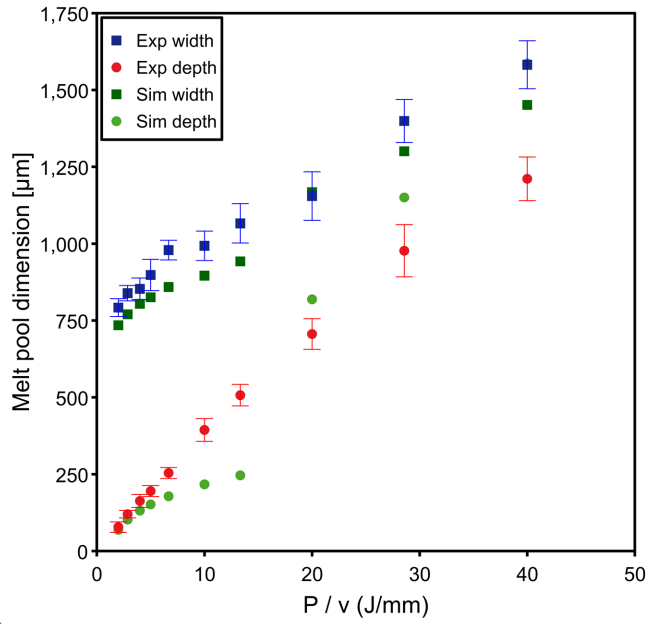

Figure 155: A comparison of the experimental and calculated melt pool width and depth for all the experiments. The error bars on the experimental data are also shown.

3D Plots

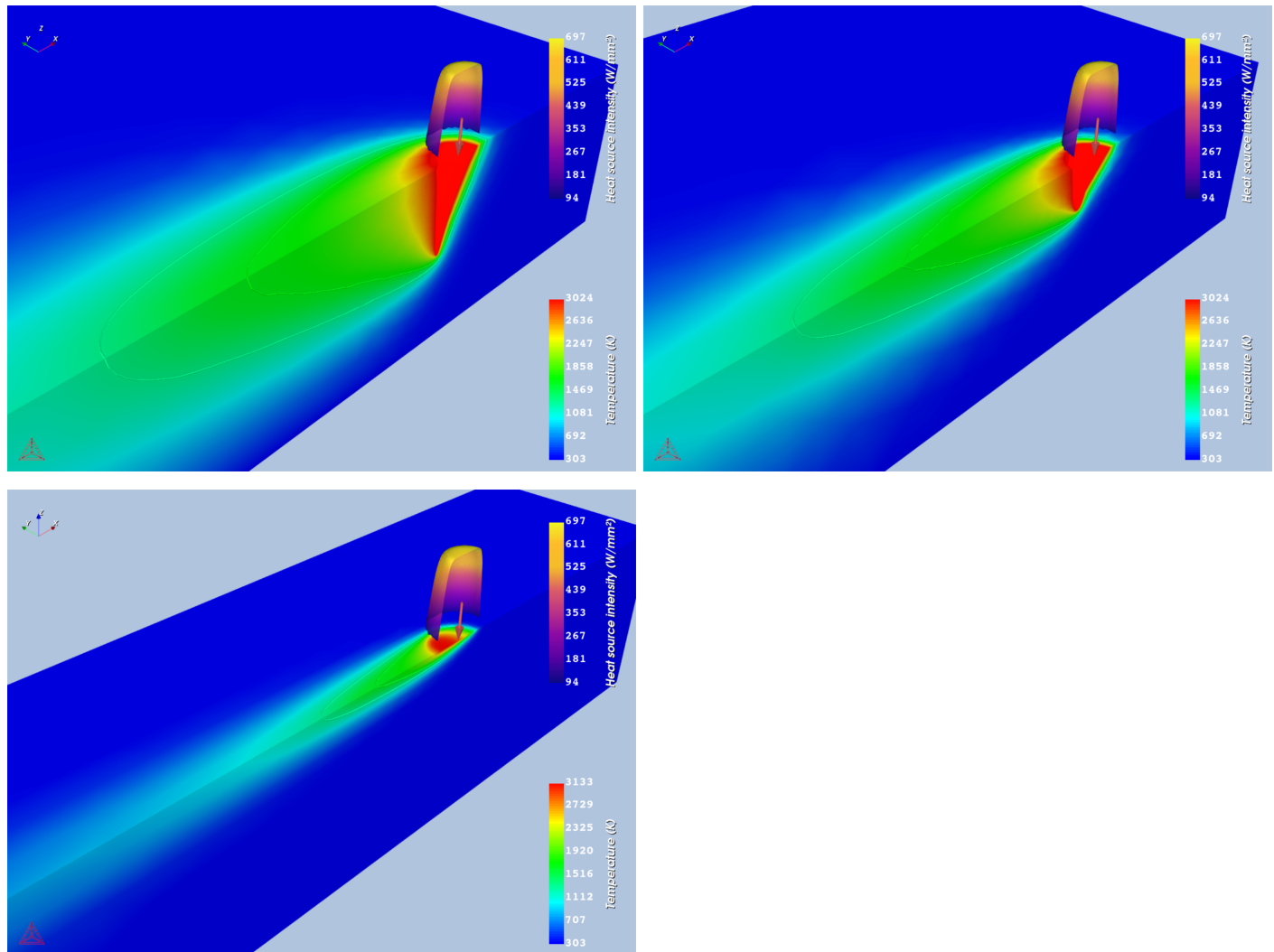

Figure 156: A comparison of the temperature distribution for three different processing conditions: (top-left) $P=1000\text{ W}$, $V=25\text{ mm/s}$, (top-right) $P=1000\text{ W}$, $V=50\text{ mm/s}$, both of which form keyhole during melting and (bottom-left) $P=1000\text{ W}$, $V=250\text{ mm/s}$ that undergoes melting in conduction mode.

For the comparisons in Figure 157, all cross-sections are taken where the melt pools attain maximum width and depth. Red and blue isocontours show liquidus and solidus temperatures, respectively.

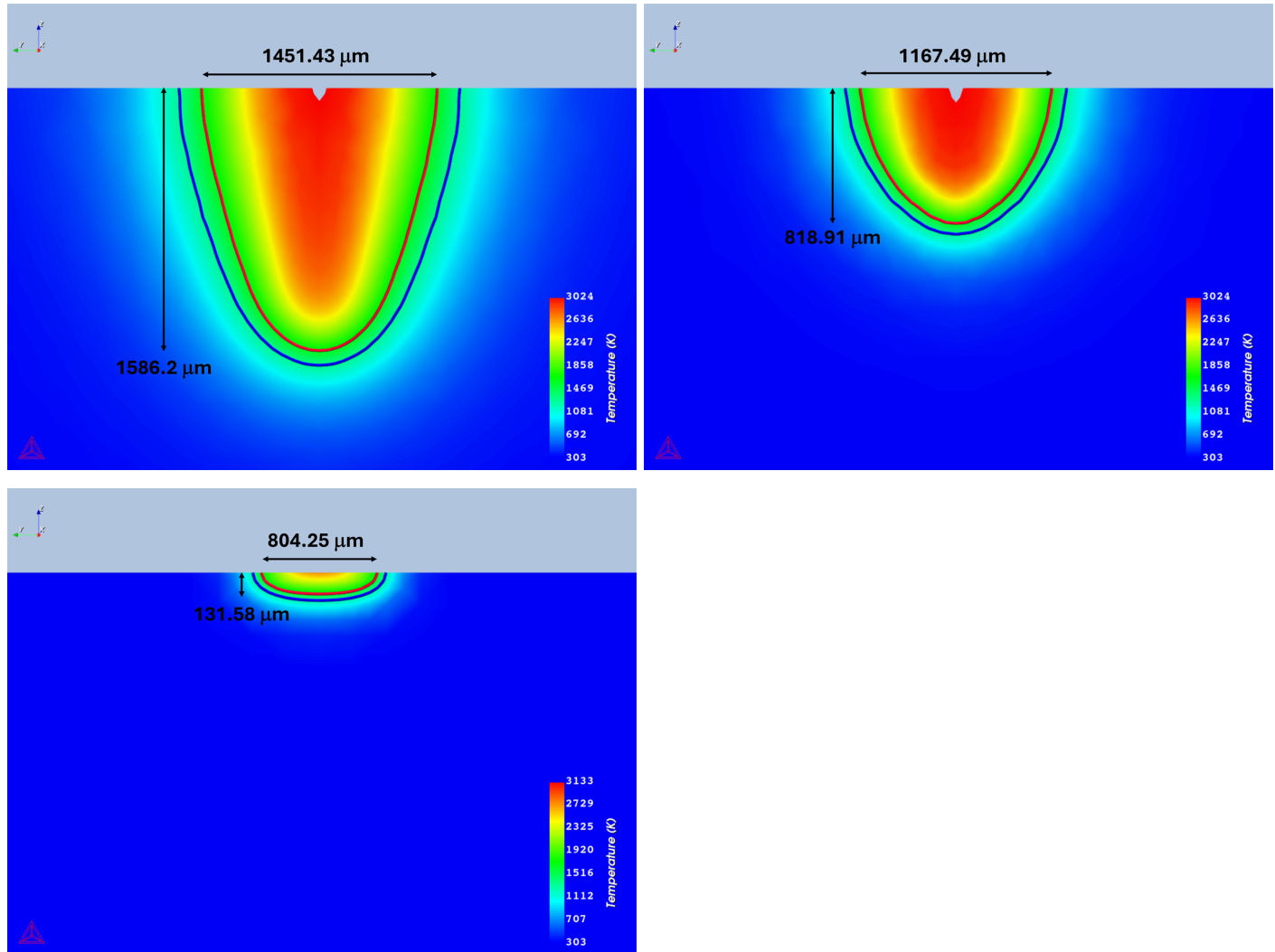

Figure 157: Cross-sections comparing melt pool shape and size for (top-left) $P=1000$ W, $V=25$ mm/s, (top-right) $P=1000$ W, $V=50$ mm/s and (bottom-left) $P=1000$ W, $V=250$ mm/s.

Other Resources



Read more about the [Additive Manufacturing \(AM\) Module](#) on our website including the details about database compatibility or to watch an [introductory webinar](#). You can also use the [Getting Started Guide](#) to learn about the key features available.



Many of our Graphical Mode examples have video tutorials, which you can access in a variety of ways. When in Thermo-Calc, from the menu select **Help → Video Tutorials**, or from the main My Project window, click **Video Tutorials**. Alternately, you can go to the [website](#) or our [YouTube channel](#).

Reference

[2020Sow] M. C. Sow, T. De Terris, O. Castelnau, Z. Hamouche, F. Coste, R. Fabbro, P. Peyre, Influence of beam diameter on Laser Powder Bed Fusion (L-PBF) process. *Addit. Manuf.* 36, 101532 (2020).

AM_15: Electron Beam Melting in an IN718 Alloy

This steady-state example demonstrates the use of **Electron Beam Heat Source** for **Batch** calculations.

The experimental data as well as the process conditions are taken from [2019Din]. The steady-state calculations represent single bead experiments where electron beam was used to scan an IN718 base plate at 1025 °C. The example also compares the predicted melt pool dimensions with the experimental data from this paper.



For TC-Python users, there is a comparable example: `pyex_AM_12_Electron_Beam_Melting_IN718.py`.

Project File and License Information

- Folder: **Additive Manufacturing**
- File name: `AM_15_Electron_Beam_Melting_IN718.tcu`



This example requires an Additive Manufacturing (AM) Module license.

Background

In an Electron Beam melting (EBM) process, a high energy electron beam is used to selectively melt the powder layer inside a vacuum chamber. In the Additive Manufacturing (AM) Module, the energy distribution from the electron beam is approximated using a Gaussian profile. In the paper [2019Din], authors performed a series of single bead experiments on the IN718 base plate (Case B in the paper) using an A2X EBM system (Arcam AB). The process was performed under a controlled vacuum.

Material Properties

- IN718: Ni-0.05C-0.14Mn-0.08Si-18.27Cr-0.57Al-2.9Mo-5.15Nb-0.01Ta-1.04Ti-0.79Co-19.18Fe-0.04Cu Mass percent
- Database: TCNI12 and with interface scattering = 1e-07. The material properties are precalculated, and stored as a built-in material library with the Additive Manufacturing (AM) Module.

AM Calculator Configuration Settings

This example contains one AM Calculator, which is renamed to **Electron Beam Melting**. On the **Configuration** window, **Conditions** tab, this **Steady-state** calculation is configured with the **Electron Beam** Heat Source with the **Keyhole model** and includes **Fluid flow**.

The **Gas pressure** is set to 0.2 Pascal. The **Base plate temperature** as well as the **Ambient temperature** are set to 1025 °C. The **Height** of the base plate is set to 3.0 mm.

The **Absorptivity** of the Electron Beam heat source is set to be **Calculated** with a **prefactor** of 1.0. The **Acceleration voltage** of the beam, as mentioned in the paper, is set 60.0 kV.

The **Beam radius** of the electron beam is not mentioned in the experimental setup of the paper. We have set the Beam radius to 125.0 μm , which is also the minimum beam radius of the A2X EBM system. The **Convective heat transfer coefficient** is set to 0.0 W/m^2 to eliminate any heat loss due to convection in the vacuum chamber.

Experimental data for the **Batch** calculation is taken from Case B in the paper (single bead experiments on a bare metal plate). Data for low scanning speed i.e. < 300 mm/s is not included in the example.

Visualizations

Open the example project file to review the node setup on the **Project** window and the associated settings on the **Configuration** window for each node. For some types of projects, you can also adjust settings on the **Plot Renderer Configuration** window to preview results before performing the simulation. Click **Perform Tree** to generate plots and tables to see the results on the **Visualizations** window.

Parity Plot

This specific Parity plot is shown by clicking the **Parity Plot** node in the **Project** window. Then you can see on the **Visualizations** window it is in the tab of the same name. The settings are located on the **Configuration** window on the **Batch** tab.

The image displays three overlapping windows from the Thermo-Calc software interface:

- Project Window:** Shows a hierarchical tree structure. The root node is 'IN718', which branches into 'Electron Beam Melting'. Under 'Electron Beam Melting', there are two sub-nodes: '3D Plot' and 'Parity Plot'. The 'Parity Plot' node is highlighted with a green border.
- Visualizations Window:** Located at the top right, it has three tabs: 'Electron Beam Melting', 'Parity Plot', and '3D Plot'. The 'Parity Plot' tab is currently selected.
- Configuration Window:** Located at the bottom right, it is titled 'Configuration' and has a sub-tab 'Parity Plot'. It contains settings for the 'Electron Beam Melting' node. The 'Batch' tab is selected. The 'Plot type' is set to 'Parity Plot'. There are three checked checkboxes: 'Plot width', 'Plot depth', and 'Show limits'. The 'RMS' value is set to 15.0.

The plot compares experimental and calculated melt pool width and depth for all experiments. The experiments are single bead experiments on bare plate IN718 with varied power and scan speed using an **Electron Beam** heat source.

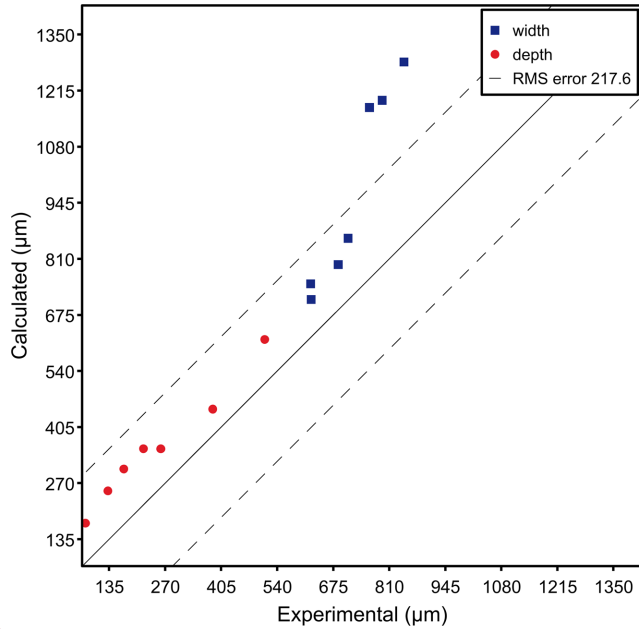

Figure 158: Parity plot comparing experimental and calculated melt pool width and depth for all the experiments when using an Electron Beam heat source. The Root Mean Square (RMS) error can also be seen as a dashed line.

3D Plots

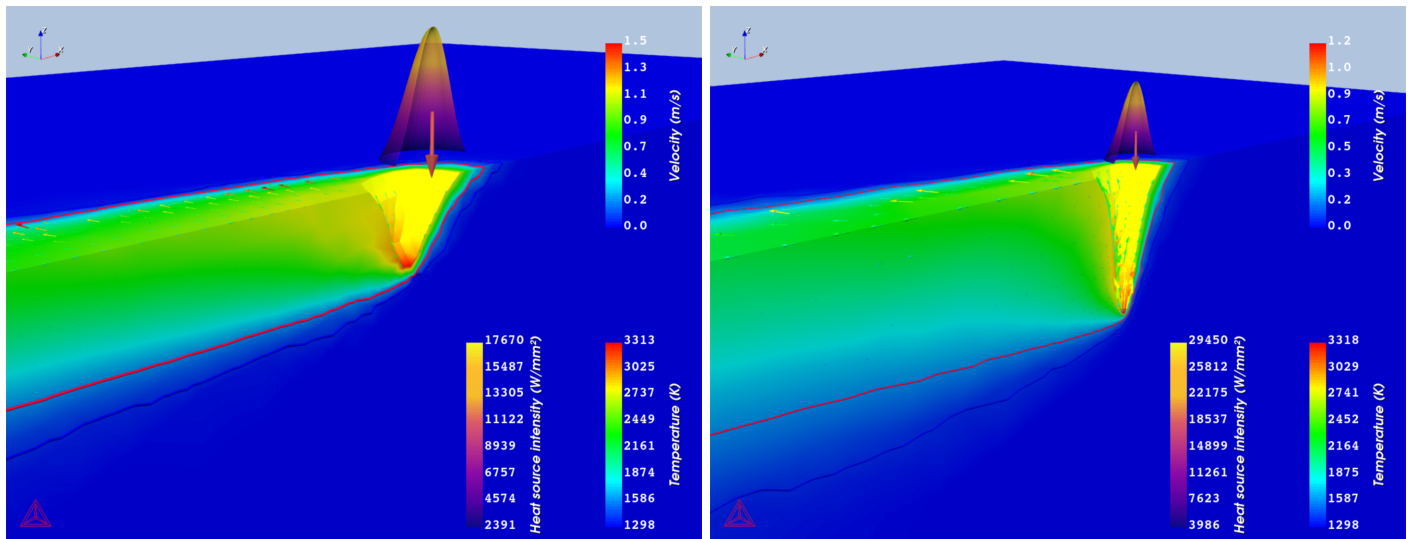

Figure 159: A comparison of the keyhole profile for two different processing conditions (left) $P=600\text{ W}$, $v=1000\text{ mm/s}$, and (right) $P=1000\text{ W}$, $v=300\text{ mm/s}$.

Other Resources



Read more about the [Additive Manufacturing \(AM\) Module](#) on our website including the details about database compatibility or to watch an [introductory webinar](#). You can also use the [Getting Started Guide](#) to learn about the key features available.



Many of our Graphical Mode examples have video tutorials, which you can access in a variety of ways. When in Thermo-Calc, from the menu select **Help** → **Video Tutorials**, or from the main My Project window, click **Video Tutorials**. Alternately, you can go to the [website](#) or our [YouTube channel](#).

Reference

[2019Din] X. Ding, Y. Koizumi, D. Wei, and A. Chiba, “Effect of process parameters on melt pool geometry and microstructure development for electron beam melting of IN718: A systematic single bead analysis study,” *Addit. Manuf.*, vol. 26, pp. 215–226, Mar. 2019.

Diffusion Module (DICTRA) Examples Collection



These are the Graphical Mode examples. There are separate Console Mode examples also available.



Examples using up to three elements are available to all users. The other examples require a Diffusion Module (DICTRA) license to calculate and plot results.



[The Role of Diffusion in Materials: A Tutorial](#) is available for download on our website. It is intended for engineers interested in using the Diffusion Module (DICTRA), as well as students learning about the role of diffusion in materials. It is designed to be useful at many levels, from undergraduate studies to someone with a PhD and experience in a related field.

These examples use the **Diffusion Calculator**. All examples use demonstration database packages included with your installation no matter what licenses you have.

In this section:

D_01: Homogenization of a Binary Fe-Ni Alloy	234
D_02: Ferrite(bcc)/Austenite(fcc) Transformation in a Binary Fe-C Alloy	237
D_03: Evolution of an Fe-Cr-Ni Diffusion Couple	240
D_04: Fe-C Moving Boundary - Austenite to Ferrite	243
D_05: $\gamma/\alpha/\gamma$ Diffusion Couple of Fe-Ni-Cr alloys	248
D_06: Diffusion Through a Tube Wall	254
D_07: Multiphase Carburization of an Alloy	258
D_08: Microsegregation During Solidification	262
D_09: Ni Post Weld Heat Treatment	265
D_10: Iron (Fe) Homogenization in Scheil	269

D_01: Homogenization of a Binary Fe-Ni Alloy

The single phase example simulates the diffusion of Fe and Ni at a temperature of 1400 K in a planar domain. At this temperature the material is fully austenitic, i.e. the only phase present is the so-called fcc (face centered cubic) phase. Initially, there is a linear variation in Ni going from 10 mass-% on the left-hand side to 50 mass-% on the right-hand side.

Project File Information

- Folder: **Diffusion Module - DICTRA**
- File name: `D_01_Diffusion_Single_Phase.tcu`



This example is part of the *Diffusion Module (DICTRA) Quick Start Guide* available to all users. A version of the example is also available for Console Mode.

Visualizations



This example is included as a Diffusion Module (DICTRA) tutorial on our [website](#) and as part of the playlist on our [YouTube channel](#).

Open the example project file to review the node setup on the **Project** window and the associated settings on the **Configuration** window for each node. For some types of projects, you can also adjust settings on the **Plot Renderer Configuration** window to preview results before performing the simulation. Click **Perform Tree** to generate plots and tables to see the results on the **Visualizations** window.

There is a variety of information shown in the **Visualizations** window that can be viewed during configuration and after performing the calculation.

- **Composition Profiles** and **Thermal Profile**: When setting up a calculator on a **Configuration** window you can preview the profile and adjust settings as needed. When you click a calculator node in the **Project** window, the matching name of the node is on the tab(s) displayed in the **Visualizations** window.
 - **Plot** or **Table** results: After completing the set up and performing the calculation, to view the matching name of the node on tab(s) in the **Visualizations** window, either click a **Plot Renderer** or **Table Renderer** node in the **Project** window or click the tabs individually in the **Visualizations** window.
-

Visualizations	
Diffusion single region Austenite	Composition of Ni vs Distance
Composition Profile	Thermal Profile

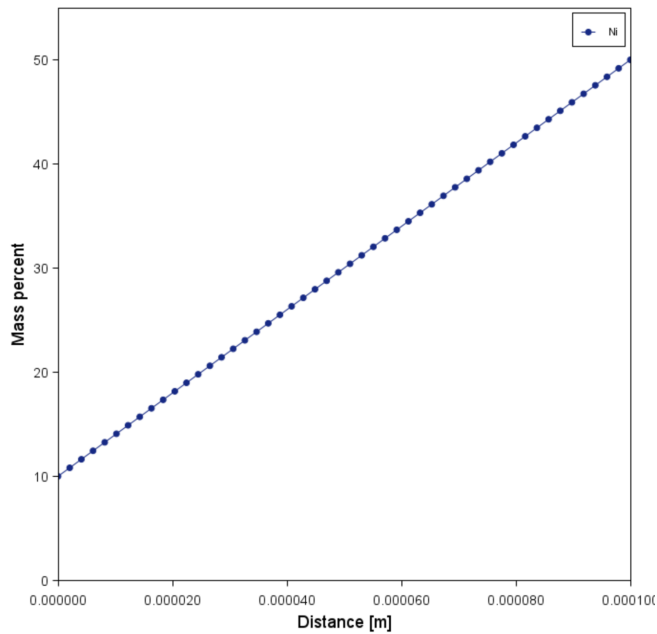

Figure 160: During set up of the calculation, you can preview the Composition Profile (shown) or Thermal Profile. Click the tab(s) in the Visualizations window to switch between these previews and adjust settings on the Diffusion Calculator Configuration window. For an Isothermal Thermal Profile this shows the constant temperature as entered.

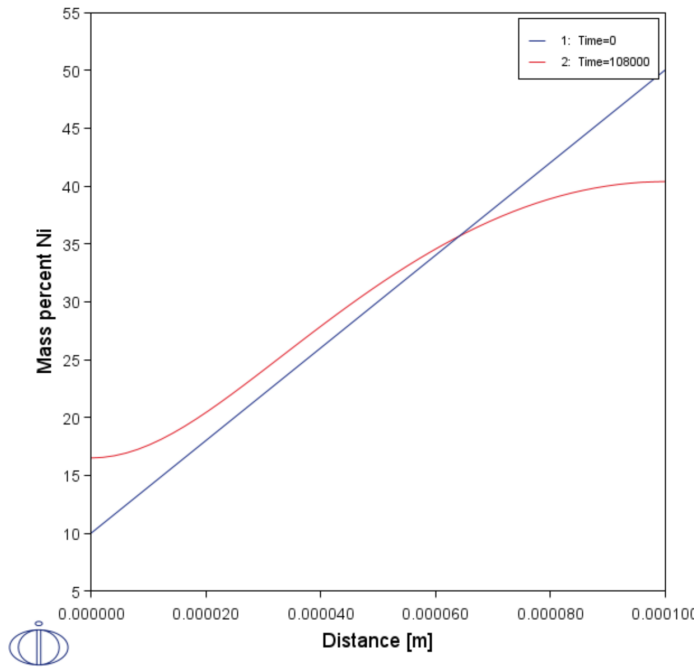

Figure 161: After performing the calculation, you can view the result on the Composition of Ni vs Distance tab, which shows the initial and final Ni profile. In this example, the Plot Renderer is renamed and this matches the tab name in the Visualizations window.

D_02: Ferrite(bcc)/Austenite(fcc) Transformation in a Binary Fe-C Alloy

The moving phase boundary example simulates the growth of ferrite (bcc) into austenite (fcc). The austenite is assumed to be initially homogeneous with the composition Fe-0.15 mass-% C. The transformation temperature is 1050 K. The initial thickness of the austenite is 2 mm and an initially very thin ferrite (1 nm) is also present at the start of the simulation.

Project File Information

- Folder: **Diffusion Module - DICTRA**
- File name: `D_02_Diffusion_Moving_Boundary.tcu`



This example is part of the *Diffusion Module (DICTRA) Quick Start Guide* available to all users. A version of the example is also available for Console Mode.

Visualizations



This example is included as a Diffusion Module (DICTRA) tutorial on our [website](#) and as part of the playlist on our [YouTube channel](#).

Open the example project file to review the node setup on the **Project** window and the associated settings on the **Configuration** window for each node. For some types of projects, you can also adjust settings on the **Plot Renderer Configuration** window to preview results before performing the simulation. Click **Perform Tree** to generate plots and tables to see the results on the **Visualizations** window.

There is a variety of information shown in the **Visualizations** window that can be viewed during configuration and after performing the calculation.

- **Composition Profiles** and **Thermal Profile**: When setting up a calculator on a **Configuration** window you can preview the profile and adjust settings as needed. When you click a calculator node in the **Project** window, the matching name of the node is on the tab(s) displayed in the **Visualizations** window.
- **Plot** or **Table** results: After completing the set up and performing the calculation, to view the matching name of the node on tab(s) in the **Visualizations** window, either click a **Plot Renderer** or **Table Renderer** node in the **Project** window or click the tabs individually in the **Visualizations** window.

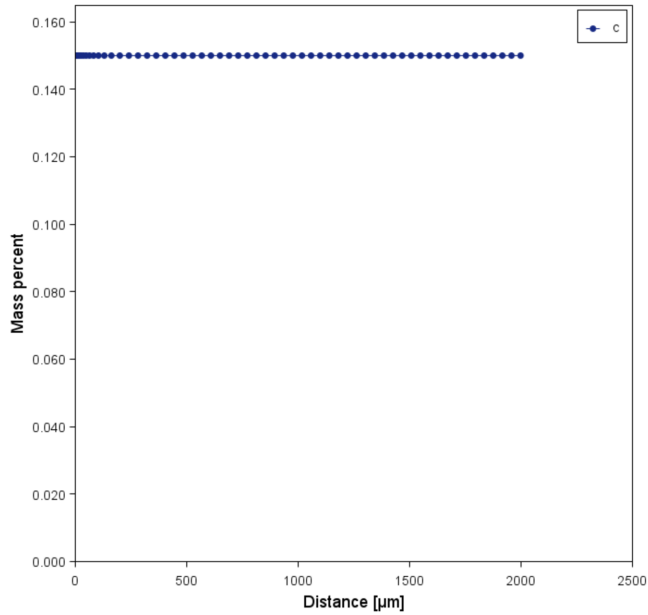

Figure 162: During set up of the calculation, you can preview the Composition Profile (shown) or Thermal Profile. Click the tab(s) in the Visualizations window to switch between these previews and adjust settings on the Diffusion Calculator Configuration window. For an Isothermal Thermal Profile this shows the constant temperature as entered.

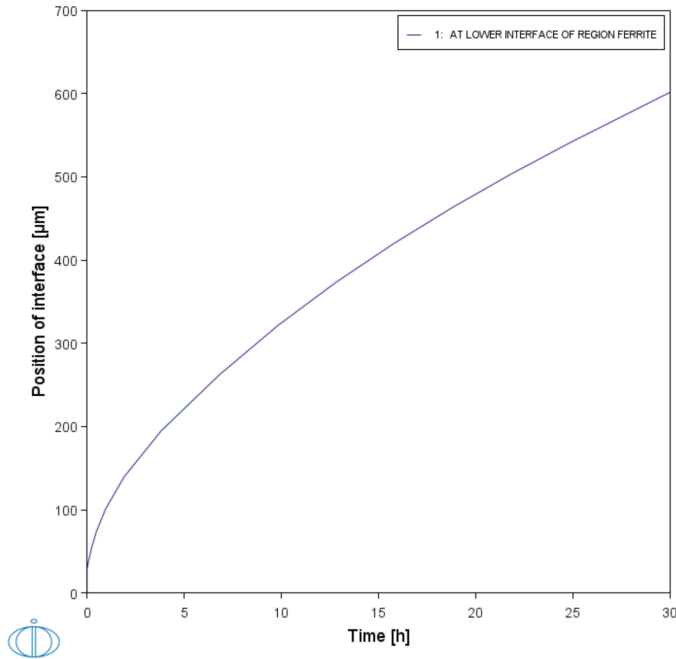

Figure 163: After performing the calculation, you can view the result on the Position of interface vs time tab. In this example, the Plot Renderer is renamed and this matches the tab name in the Visualizations window.

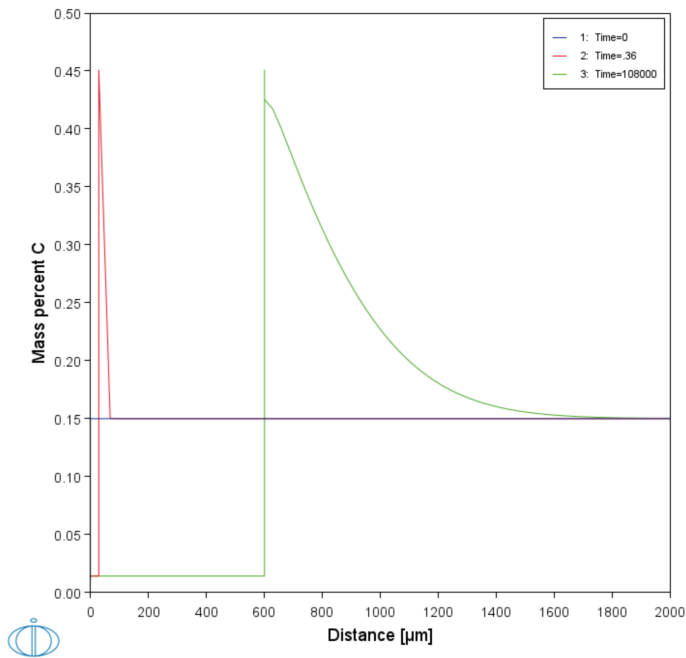

Figure 164: After performing the calculation, you can view the result on the Composition profile C tab. In this example, the Plot Renderer is renamed and this matches the tab name in the Visualizations window.

D_03: Evolution of an Fe-Cr-Ni Diffusion Couple

The multiphase example simulates the evolution of an Fe-Cr-Ni diffusion couple during a 100 hour heat treatment at 1100° C (1373.15 K). Both end members of the diffusion couple are duplex ferrite plus austenite, but the majority phase is ferrite on the left-hand side and austenite on the right.

With this type of simulation it is assumed that the material is fully equilibrated at each grid point, i.e. the local phase fractions, phase compositions and so forth are obtained from an equilibrium calculation with the local overall composition as a condition.

More details about the homogenization model for multiphase simulations can be found in Larsson and Engström [2006Lar] and Larsson and Höglund [2009Lar]. Experimental data is from Engström [1995Eng].

Project File Information

- Folder: **Diffusion Module - DICTRA**
- File name: `D_03_Diffusion_Multiphase.tcu`



This example is part of the *Diffusion Module (DICTRA) Quick Start Guide* available to all users. A version of the example is also available for Console Mode.

Visualizations



Many of our Graphical Mode examples have video tutorials, which you can access in a variety of ways. When in Thermo-Calc, from the menu select **Help → Video Tutorials**, or from the main My Project window, click **Video Tutorials**. Alternately, you can go to the [website](#) or our [YouTube channel](#).

Open the example project file to review the node setup on the **Project** window and the associated settings on the **Configuration** window for each node. For some types of projects, you can also adjust settings on the **Plot Renderer Configuration** window to preview results before performing the simulation. Click **Perform Tree** to generate plots and tables to see the results on the **Visualizations** window.

There is a variety of information shown in the **Visualizations** window that can be viewed during configuration and after performing the calculation.

- **Composition Profiles** and **Thermal Profile**: When setting up a calculator on a **Configuration** window you can preview the profile and adjust settings as needed. When you click a calculator node in the **Project** window, the matching name of the node is on the tab(s) displayed in the **Visualizations** window.
-

- **Plot or Table** results: After completing the set up and performing the calculation, to view the matching name of the node on tab(s) in the **Visualizations** window, either click a **Plot Renderer** or **Table Renderer** node in the **Project** window or click the tabs individually in the **Visualizations** window.

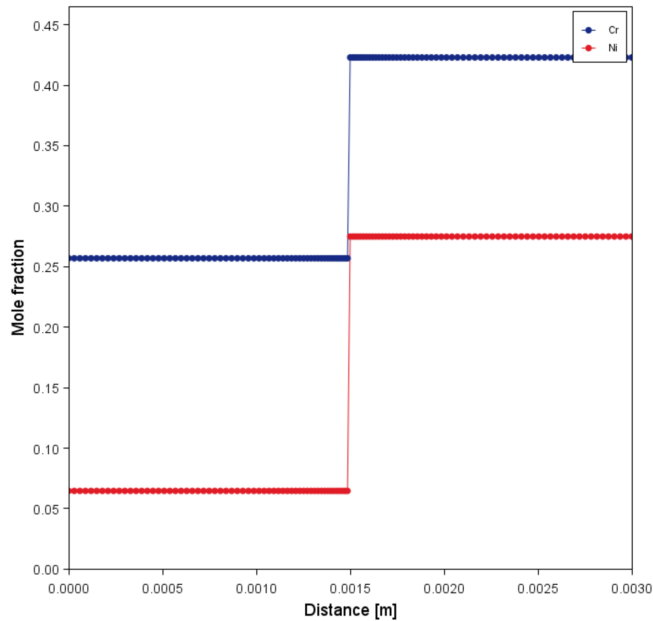

Figure 165: During set up of the calculation, you can preview the Composition Profile (shown) or Thermal Profile. Click the tab(s) in the Visualizations window to switch between these previews and adjust settings on the Diffusion Calculator Configuration window. For an Isothermal Thermal Profile this shows the constant temperature as entered.

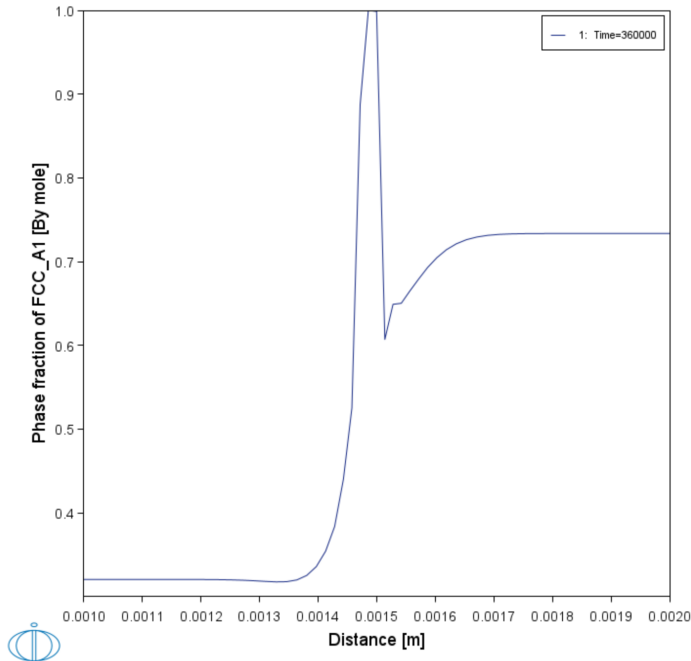

Figure 166: After performing the calculation, you can view the result on the Phase fraction of FCC tab. In this example, the Plot Renderer is renamed and this matches the tab name in the Visualizations window.

References

- [1995Eng] A. Engström, Interdiffusion in multiphase, Fe-Cr-Ni diffusion couples. *Scand. J. Metall.* 24, 12–20 (1995).
- [2006Lar] H. Larsson, A. Engström, A homogenization approach to diffusion simulations applied to $\alpha+\gamma$ Fe–Cr–Ni diffusion couples. *Acta Mater.* 54, 2431–2439 (2006).
- [2009Lar] H. Larsson, L. Höglund, Multiphase diffusion simulations in 1D using the DICTRA homogenization model. *Calphad.* 33, 495–501 (2009).

D_04: Fe-C Moving Boundary - Austenite to Ferrite

This example simulates the austenite to ferrite transformation in a Fe-0.01 mass% C steel during continuous cooling. The simulation starts at a temperature where only austenite is stable, ferrite nucleates and grows into the austenite during cooling in the two phase region. Plots of thermal and carbon composition profiles are generated.

Project File Information

- Folder: **Diffusion Module - DICTRA**
- File name: `D_04_Diffusion_Fe-C_Moving_Boundary_Austenite_to_Ferrite.tcu`

Visualizations



Many of our Graphical Mode examples have video tutorials, which you can access in a variety of ways. When in Thermo-Calc, from the menu select **Help** → **Video Tutorials**, or from the main My Project window, click **Video Tutorials**. Alternately, you can go to the [website](#) or our [YouTube channel](#).

Open the example project file to review the node setup on the **Project** window and the associated settings on the **Configuration** window for each node. For some types of projects, you can also adjust settings on the **Plot Renderer Configuration** window to preview results before performing the simulation. Click **Perform Tree** to generate plots and tables to see the results on the **Visualizations** window.

There is a variety of information shown in the **Visualizations** window that can be viewed during configuration and after performing the calculation.

- **Composition Profiles** and **Thermal Profile**: When setting up a calculator on a **Configuration** window you can preview the profile and adjust settings as needed. When you click a calculator node in the **Project** window, the matching name of the node is on the tab(s) displayed in the **Visualizations** window.
 - **Plot** or **Table** results: After completing the set up and performing the calculation, to view the matching name of the node on tab(s) in the **Visualizations** window, either click a **Plot Renderer** or **Table Renderer** node in the **Project** window or click the tabs individually in the **Visualizations** window.
-

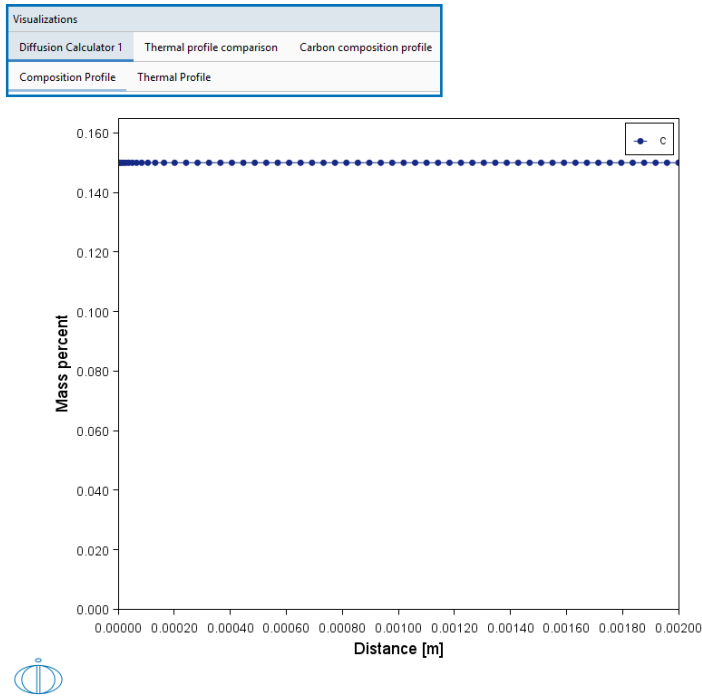

Figure 167: During set up of the calculation, preview the Composition Profile. Click the tab in the Visualizations window to switch between these previews and adjust settings on the Diffusion Calculator Configuration window.

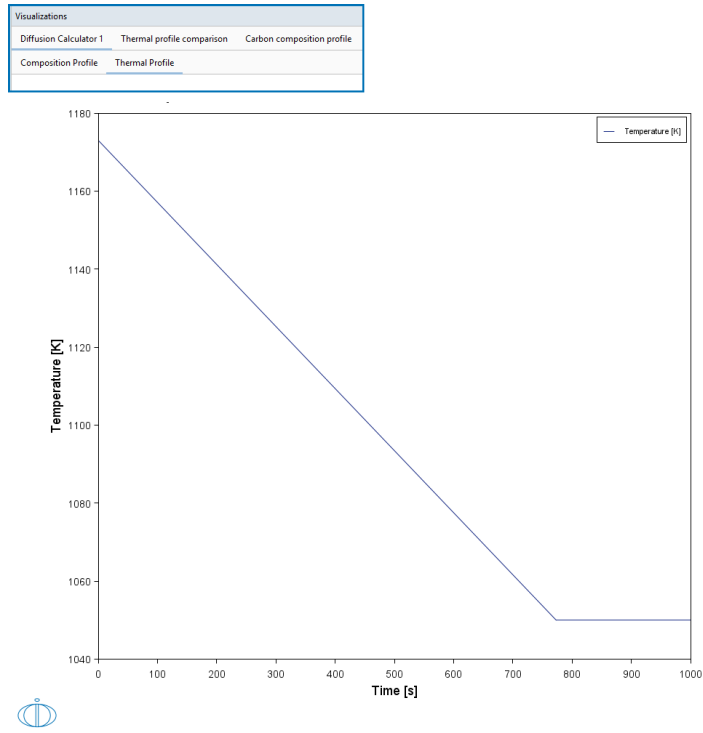

Figure 168: During set up of the calculation, preview the non-isothermal Thermal Profile. Click the tab in the Visualizations window to switch between these previews and adjust settings on the Diffusion Calculator Configuration window. Also see the plot result comparing the thermal profile for the two regions.

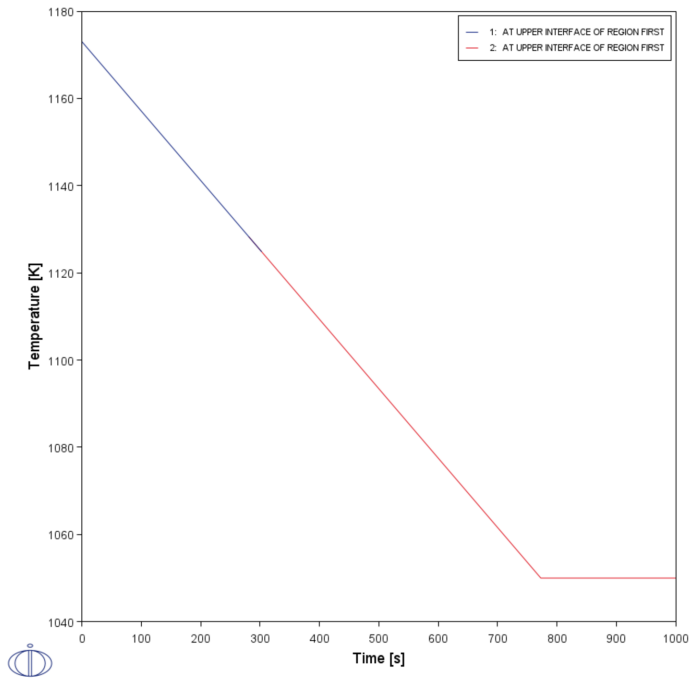

Figure 169: After performing the calculation, view the result on the Thermal profile tab. In this example, the Plot Renderer is renamed and this matches the tab name in the Visualizations window. Note that this Thermal Profile is slightly different than what you can preview during set up.

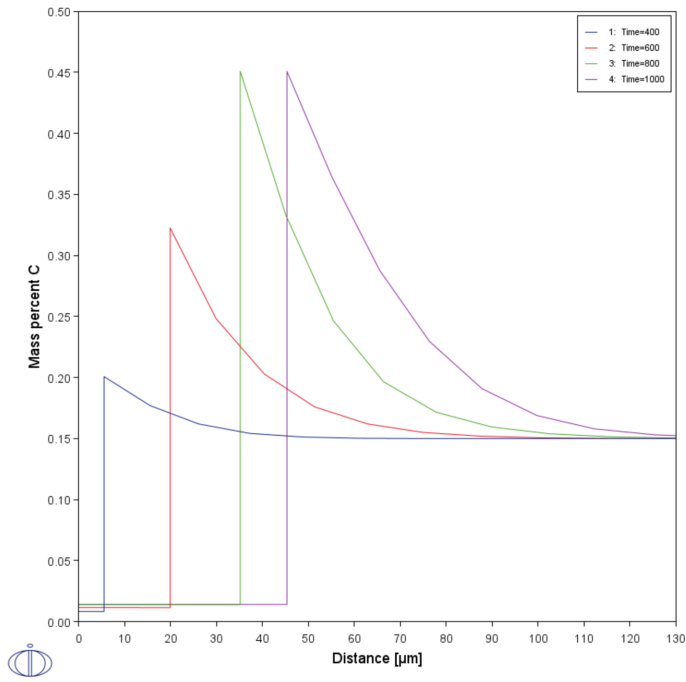
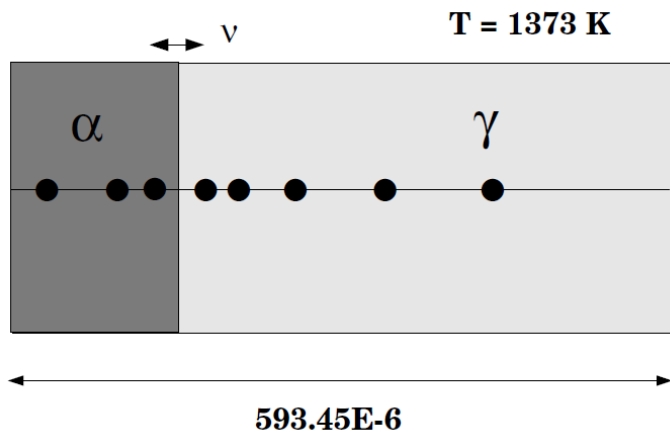

Figure 170: After performing the calculation, view the result on the Carbon composition profile tab. In this example, the Plot Renderer is renamed and this matches the tab name in the Visualizations window.

D_05: $\gamma/\alpha/\gamma$ Diffusion Couple of Fe-Ni-Cr alloys

This example demonstrates the evolution of a ternary Fe-Cr-Ni diffusion couple. A thin slice of ferrite (α phase) (38%Cr,0%Ni) is clamped between two thicker slices of austenite (γ phase) (27%Cr, 20%Ni). The assembly is subsequently heat treated at 1373 K.

This set up corresponds to diffusion couple in Kajihara et al. [1993aKaj] and Kajihara and Kikuchi [1993bKaj].



Project File Information

- Folder: **Diffusion Module - DICTRA**
- File name: `D_05_Diffusion_Fe_Ni_Cr_Moving_Boundary_Diffusion_Couple.tcu`

Visualizations



Many of our Graphical Mode examples have video tutorials, which you can access in a variety of ways. When in Thermo-Calc, from the menu select **Help** → **Video Tutorials**, or from the main My Project window, click **Video Tutorials**. Alternately, you can go to the [website](#) or our [YouTube channel](#).

Open the example project file to review the node setup on the **Project** window and the associated settings on the **Configuration** window for each node. For some types of projects, you can also adjust settings on the **Plot Renderer Configuration** window to preview results before performing the simulation. Click **Perform Tree** to generate plots and tables to see the results on the **Visualizations** window.



When you run (Perform) this example, it takes a few minutes for the calculations to complete.

There is a variety of information shown in the **Visualizations** window that can be viewed during configuration and after performing the calculation.

- **Composition Profiles** and **Thermal Profile**: When setting up a calculator on a **Configuration** window you can preview the profile and adjust settings as needed. When you click a calculator node in the **Project** window, the matching name of the node is on the tab(s) displayed in the **Visualizations** window.
- **Plot** or **Table** results: After completing the set up and performing the calculation, to view the matching name of the node on tab(s) in the **Visualizations** window, either click a **Plot Renderer** or **Table Renderer** node in the **Project** window or click the tabs individually in the **Visualizations** window.

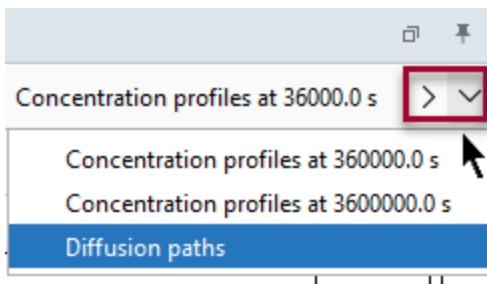

Figure 171: In this example, all Plot Renderer nodes are renamed and each match a tab name in the Visualizations window. Use the left and right arrows in the Visualizations window to move through the tabs and the down arrow to choose by name when a tab is not visible.

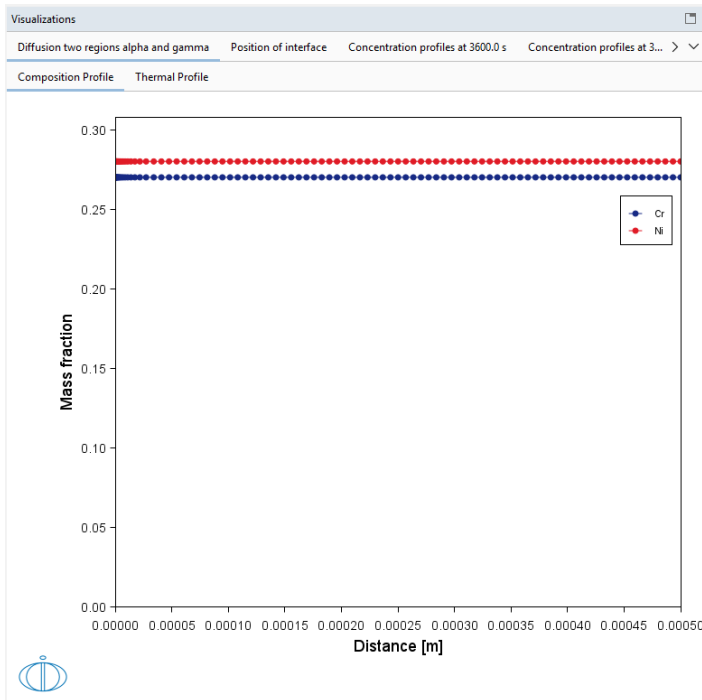

Figure 172: During set up of the calculation, preview the Composition Profile (shown) or Thermal Profile. Click the tab(s) in the Visualizations window to switch between these previews and adjust settings on the Diffusion Calculator Configuration window. For an Isothermal Thermal Profile this shows the constant temperature as entered.

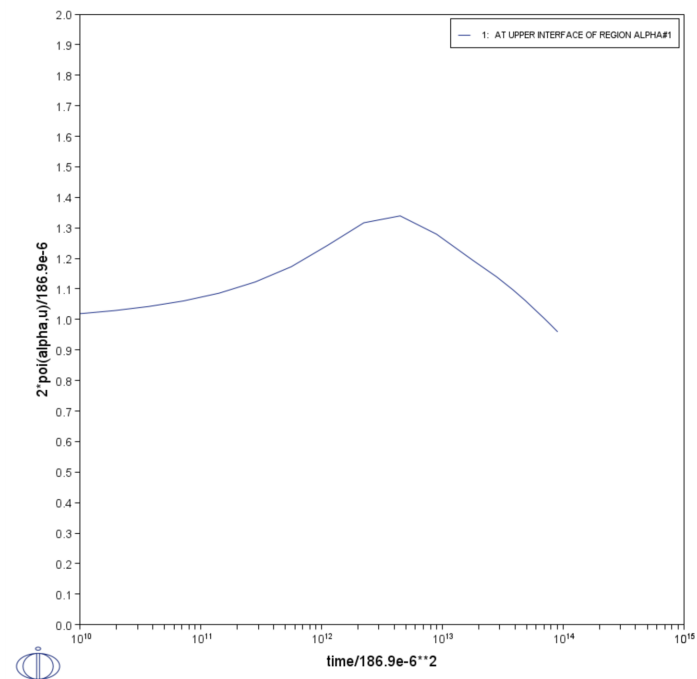

Figure 173: After performing the calculation, view the result on the Interface position tab.

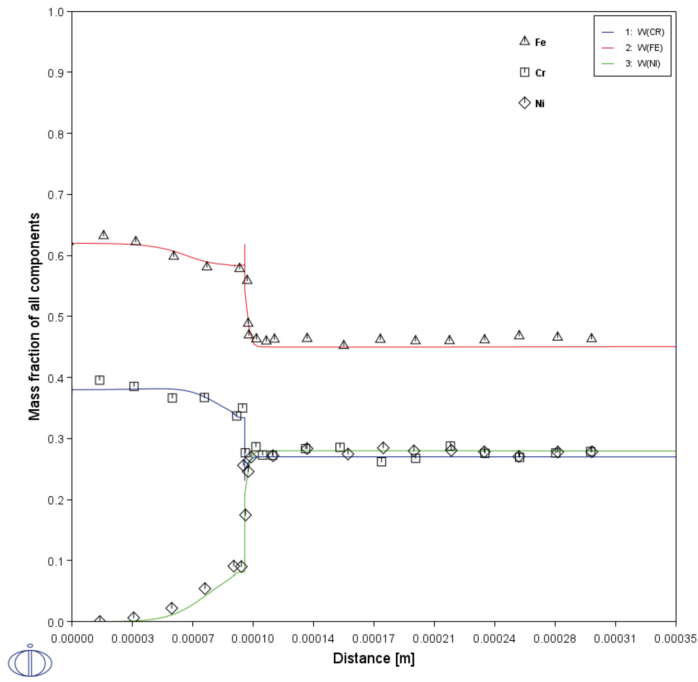

Figure 174: After performing the calculation, view the result on the Concentration profiles at 3600 s tab.

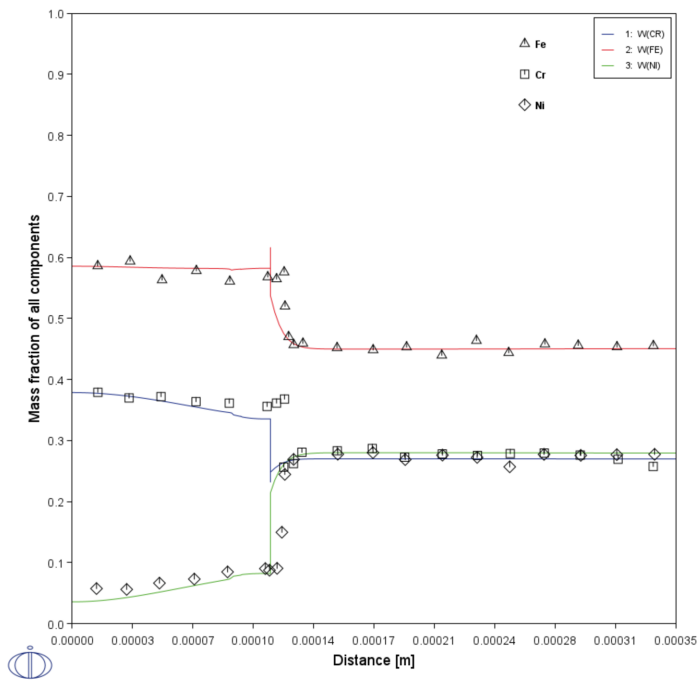

Figure 175: After performing the calculation, view the result on the Concentration profiles at 36 000 s tab.

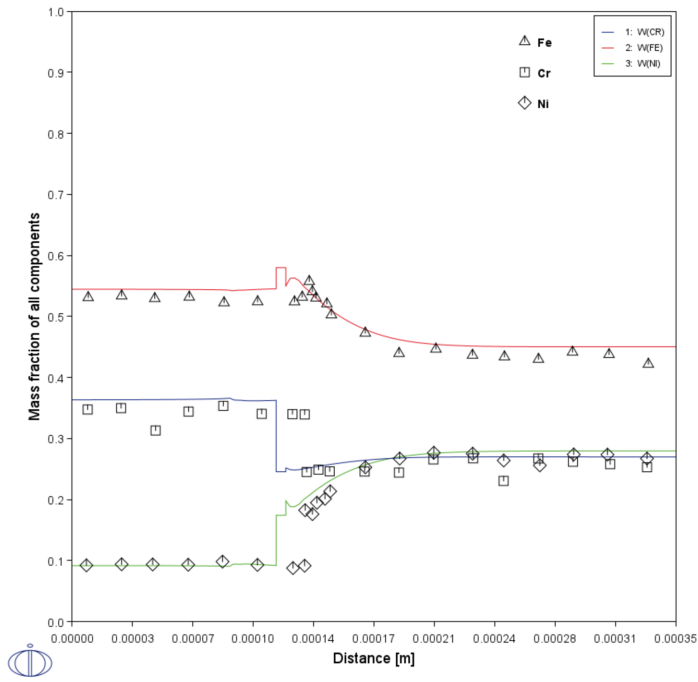

Figure 176: After performing the calculation, view the on the Concentration profiles at 360 000 s tab.

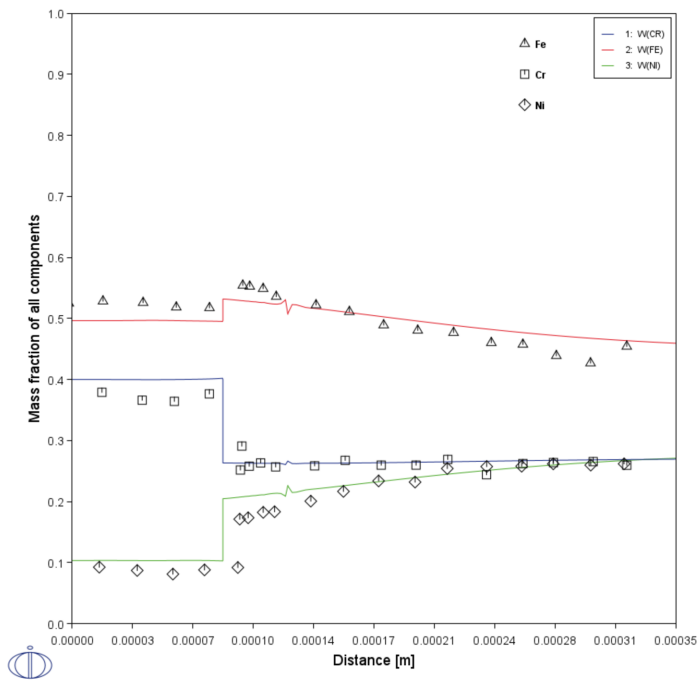

Figure 177: After performing the calculation, view the result on the Concentration profiles at 3 600 000 s tab.

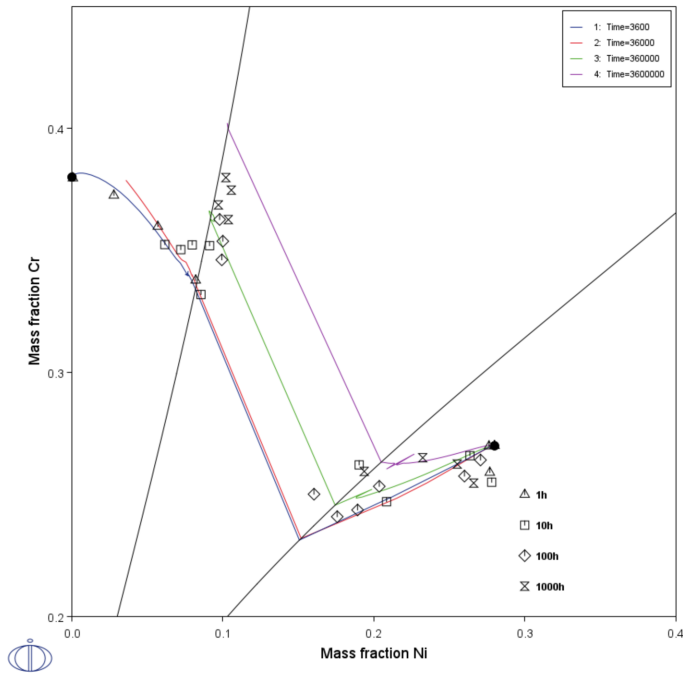

Figure 178: After performing the calculation, view the result on the Diffusion paths tab.

References

- [1993aKaj] M. Kajihara, C.-B. Lim, M. Kikuchi, Experimental Study on Dissolution of ALPHA Phase in GAMMA/ALPHA/GAMMA Diffusion Couples of the Fe-Cr-Ni System. *ISIJ Int.* 33, 498–507 (1993).
- [1993bKaj] M. Kajihara, M. Kikuchi, Numerical analysis of dissolution of α phase in $\gamma/\alpha/\gamma$ diffusion couples of the Fe-Cr-Ni system. *Acta Metall. Mater.* 41, 2045–2059 (1993).

D_06: Diffusion Through a Tube Wall

This is a simple example of diffusion through a tube wall. The tube material is an Fe-0.06Mn-0.05C alloy. Two plots comparing distance to the U-fraction of manganese and composition of carbon are generated to visualize the austenite region. A *cylindrical* geometry is used with *mixed zero flux and activity* boundary conditions.

On the inside wall a carbon activity of 0.9 is maintained whereas on the outside the carbon activity is very low. This example demonstrates the use of boundary conditions, advanced plotting and tables.

Project File Information

- Folder: **Diffusion Module - DICTRA**
- File name: `D_06_Diffusion_Carburization_Tube.tcu`



This example is based on Console Mode exab6. When in Console Mode, you can open the example from Thermo-Calc (**File** → **Examples Files** → **Diffusion Module**).

Visualizations



Many of our Graphical Mode examples have video tutorials, which you can access in a variety of ways. When in Thermo-Calc, from the menu select **Help** → **Video Tutorials**, or from the main My Project window, click **Video Tutorials**. Alternately, you can go to the [website](#) or our [YouTube channel](#).

Open the example project file to review the node setup on the **Project** window and the associated settings on the **Configuration** window for each node. For some types of projects, you can also adjust settings on the **Plot Renderer Configuration** window to preview results before performing the simulation. Click **Perform Tree** to generate plots and tables to see the results on the **Visualizations** window.

There is a variety of information shown in the **Visualizations** window that can be viewed during configuration and after performing the calculation.

- **Composition Profiles** and **Thermal Profile**: When setting up a calculator on a **Configuration** window you can preview the profile and adjust settings as needed. When you click a calculator node in the **Project** window, the matching name of the node is on the tab(s) displayed in the **Visualizations** window.
-

- **Plot or Table** results: After completing the set up and performing the calculation, to view the matching name of the node on tab(s) in the **Visualizations** window, either click a **Plot Renderer** or **Table Renderer** node in the **Project** window or click the tabs individually in the **Visualizations** window.

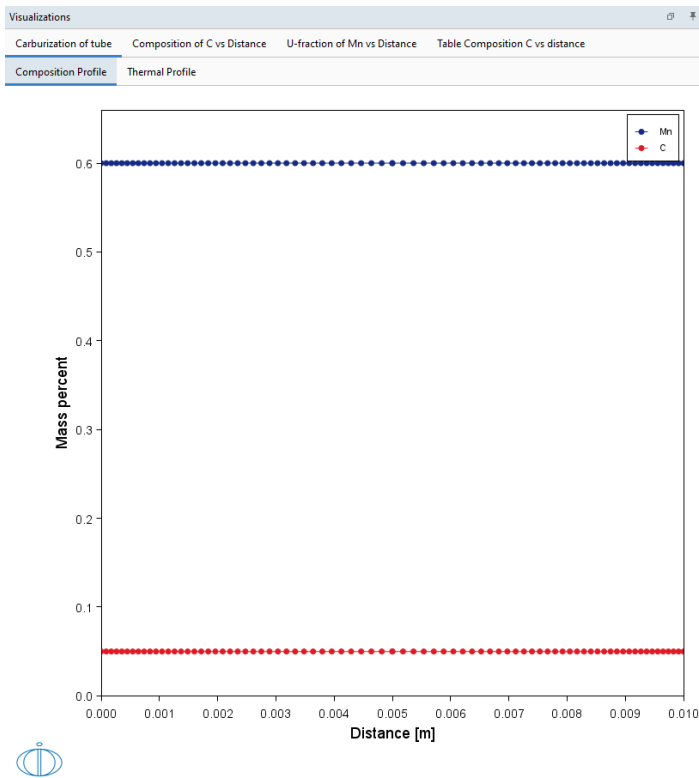

Figure 179: During set up of the calculation, you can preview the Composition Profile (shown) or Thermal Profile. Click the tab(s) in the Visualizations window to switch between these previews and adjust settings on the Diffusion Calculator Configuration window. For an Isothermal Thermal Profile this shows the constant temperature as entered.

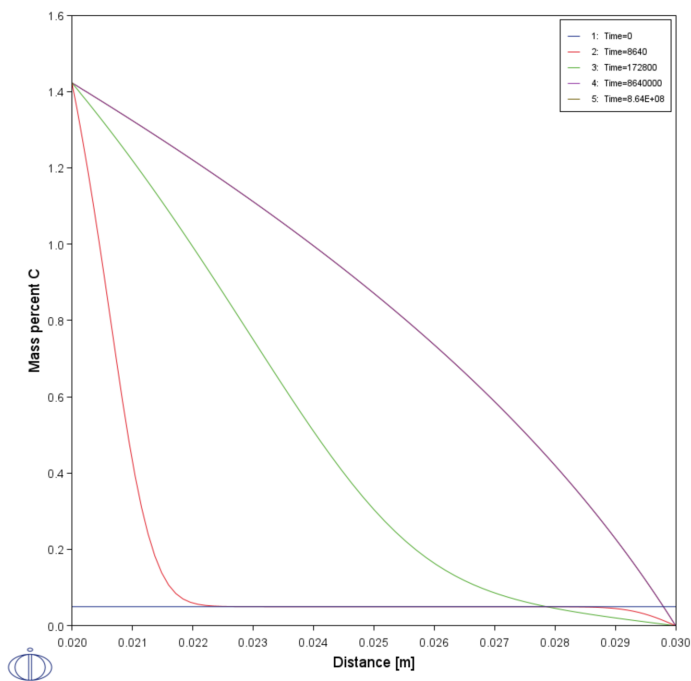

Figure 180: After performing the calculation, you can view the result on the Composition of C vs Distance tab. In this example, the Plot Renderer is renamed and this matches the tab name in the Visualizations window.

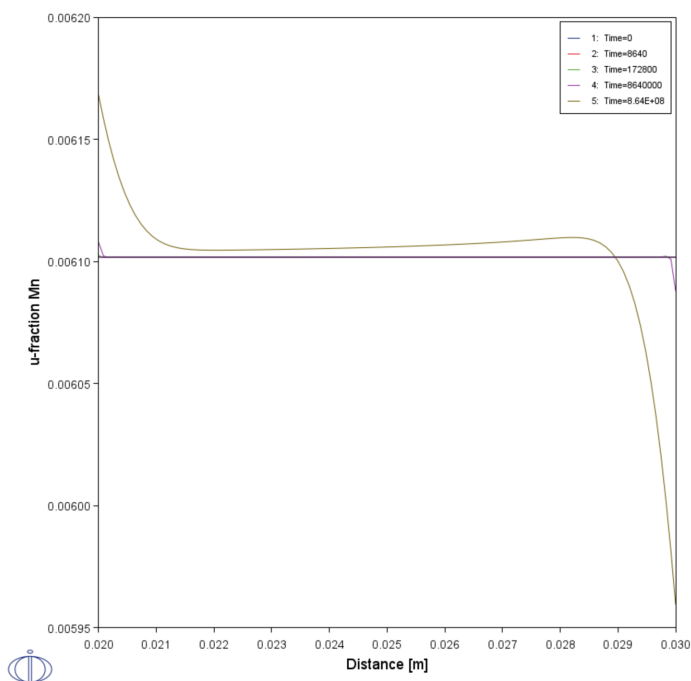

Figure 181: After performing the calculation, you can view the result on the U-fraction of Mn vs Distance tab. In this example, the Plot Renderer is renamed and this matches the tab name in the Visualizations window.

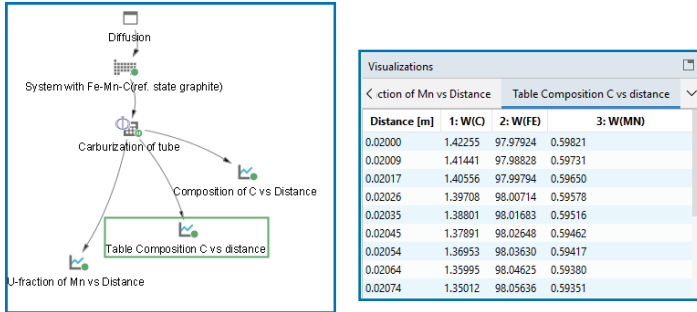

Figure 182: After performing the calculation, you can view the result on the Table Composition C vs Distance tab. In this example, the Table Renderer is renamed and this matches the tab name in the Visualizations window.

D_07: Multiphase Carburization of an Alloy

This example is based on Engström et al. [1994Eng] and is about carburization of a Ni-25Cr-0.0001C alloy. In this case the M7C3 and M3C2 carbides are entered as spheroid phases in an FCC_A1 matrix. It is similar to Graphical Mode example D_06 except the default simulation condition is automatically set to use the homogenization model.

The isothermal calculation is run for 1000 hours at a temperature of 1123 K using the mixed zero flux and activity left boundary condition. Results are plotted using two Plot Renderers and a Table Renderer.

Project File Information

- Folder: **Diffusion Module - DICTRA**
- File name: `D_07_Diffusion_Carburization_Multiphase.tcu`



This example is based on Console Mode exd1b. When in Console Mode, you can open the example from Thermo-Calc (**File** → **Examples Files** → **Diffusion Module**).

Visualizations



This example is included as a Diffusion Module (DICTRA) tutorial on our [website](#) and as part of the playlist on our [YouTube channel](#).

Open the example project file to review the node setup on the **Project** window and the associated settings on the **Configuration** window for each node. For some types of projects, you can also adjust settings on the **Plot Renderer Configuration** window to preview results before performing the simulation. Click **Perform Tree** to generate plots and tables to see the results on the **Visualizations** window.



When you run (Perform) this example, it takes a few minutes for the calculations to complete.

There is a variety of information shown in the **Visualizations** window that can be viewed during configuration and after performing the calculation.

- **Composition Profiles** and **Thermal Profile**: When setting up a calculator on a **Configuration** window you can preview the profile and adjust settings as needed. When you click a calculator node in the **Project** window, the matching name of the node is on the tab(s) displayed in the **Visualizations** window.

- **Plot or Table** results: After completing the set up and performing the calculation, to view the matching name of the node on tab(s) in the **Visualizations** window, either click a **Plot Renderer** or **Table Renderer** node in the **Project** window or click the tabs individually in the **Visualizations** window.

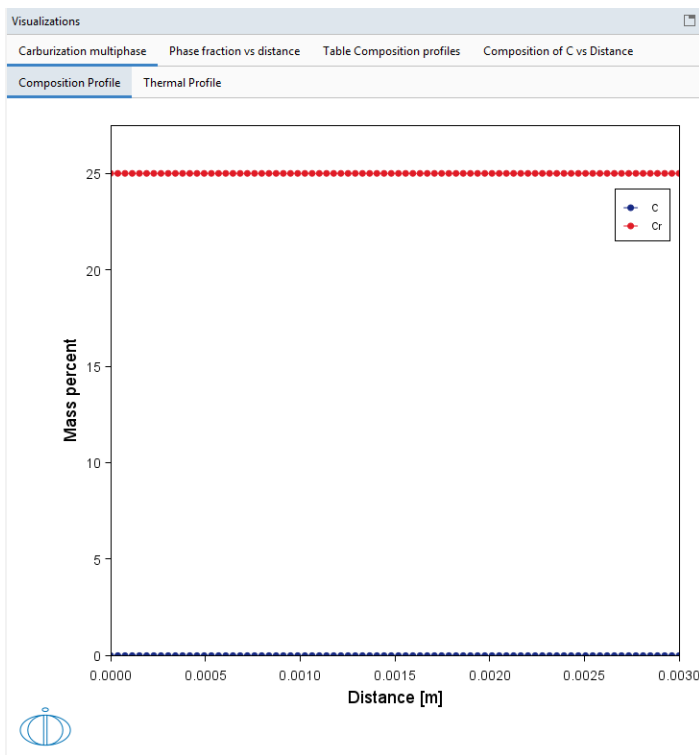

Figure 183: During set up of the calculation, you can preview the Composition Profile (shown) or Thermal Profile. Click the tab(s) in the Visualizations window to switch between these previews and adjust settings on the Diffusion Calculator Configuration window. For an Isothermal Thermal Profile this shows the constant temperature as entered.

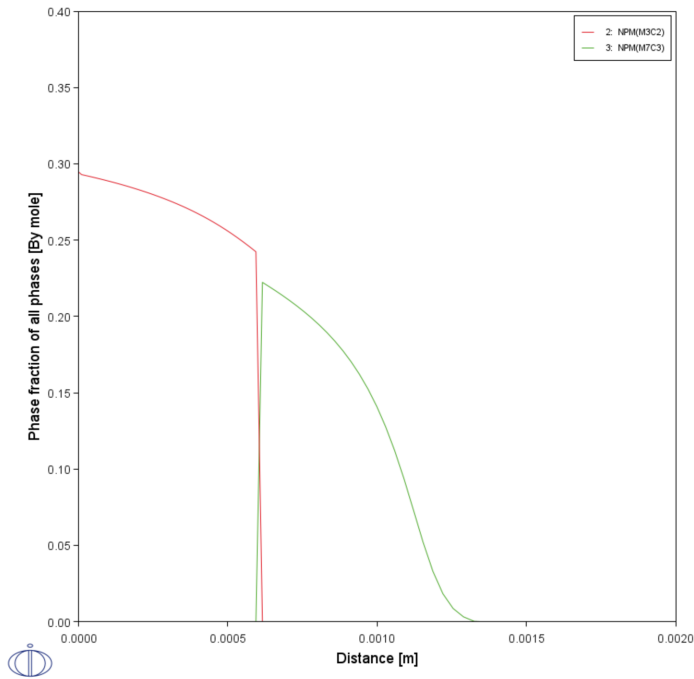

Figure 184: After performing the calculation, you can view the result on the Phase fraction vs distance tab. In this example, the Plot Renderer is renamed and this matches the tab name in the Visualizations window.

Visualizations				
Carburization multiphase		Phase fraction vs distance	Table Composition profiles	Composition of C vs Distance
Distance [m]	1: W(C)	2: W(CR)	3: W(NI)	
0.00000	2.94652	24.36016	72.69332	
9.88104E-6	2.92735	24.27154	72.80111	
0.00002	2.92100	24.27340	72.80561	

Figure 185: After performing the calculation, you can view the result on the Table of Composition profiles tab. In this example, the Table Renderer is renamed and this matches the tab name in the Visualizations window.

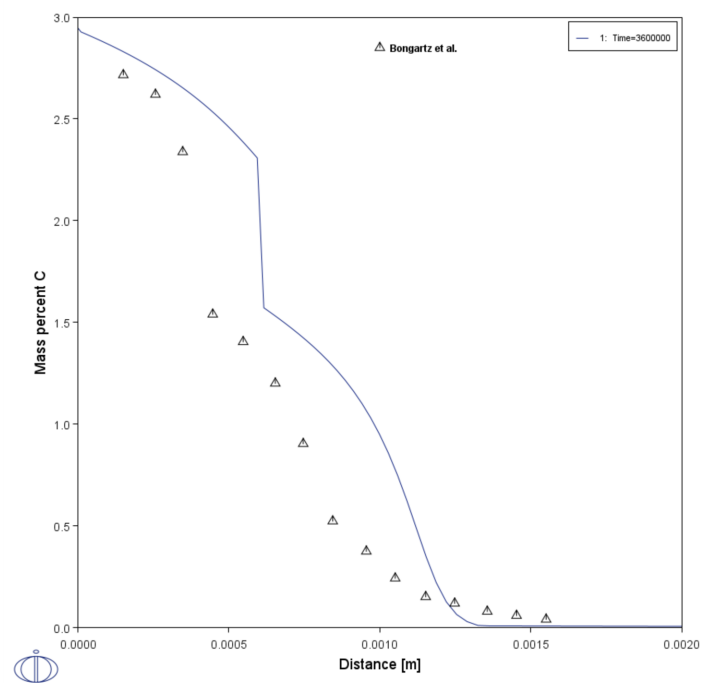

Figure 186: After performing the calculation, you can view the result on the Composition of C vs distance tab. In this example, the Plot Renderer is renamed and this matches the tab name in the Visualizations window.

Reference

[1994Eng] A. Engström, L. Höglund, J. Ågren, Computer simulation of diffusion in multiphase systems. Metall. Mater. Trans. A. 25, 1127–1134 (1994).

D_08: Microsegregation During Solidification

This application example, which is [available on our website](#), shows how Thermo-Calc together with the Diffusion Module (DICTRA) can be used to investigate and predict microsegregation (solute redistribution) during solidification.

The example is based on a real case where the elemental distribution of a continuously cast steel was measured revealing the concentration of the elements Si, Mn, and P as sketched in Figure 1. The profile results from the well-known segregation across secondary dendrite arms. The interesting point is that the elements Si and Mn show the expected positive segregation (higher concentrations) in the interdendritic regions. The peak of the P content, on the other hand, is shifted compared to Si and Mn, and, in fact, shows negative segregation in the interdendritic region. This is unexpected and counterintuitive.

The calculations are based on ones performed in the frame of a research project funded by the European Union called VESPISM – Virtual Experiments to Solve Problems in Metallurgy – conducted from 2001 to 2004.

Project File and License Information

- Folder: **Diffusion Module - DICTRA**
- File name: `D_08_Diffusion_Microsegregation_During_Solidification.tcu`



Running this calculation requires licenses for the Add-on Diffusion Module (DICTRA) plus the steels thermodynamic database (TCFE) and mobility database (MOBFE). For best results, TCFE14 and MOBFE8.1 and newer (as of 2025a) are recommended.

Visualizations



Many of our Graphical Mode examples have video tutorials, which you can access in a variety of ways. When in Thermo-Calc, from the menu select **Help → Video Tutorials**, or from the main My Project window, click **Video Tutorials**. Alternately, you can go to the [website](#) or our [YouTube channel](#).

Open the example project file to review the node setup on the **Project** window and the associated settings on the **Configuration** window for each node. For some types of projects, you can also adjust settings on the **Plot Renderer Configuration** window to preview results before performing the simulation. Click **Perform Tree** to generate plots and tables to see the results on the **Visualizations** window.



When you run (Perform) this example, it takes a few minutes for the calculations to complete.

There is a variety of information shown in the **Visualizations** window that can be viewed during configuration and after performing the calculation.

- **Composition Profiles** and **Thermal Profile**: When setting up a calculator on a **Configuration** window you can preview the profile and adjust settings as needed. When you click a calculator node in the **Project** window, the matching name of the node is on the tab(s) displayed in the **Visualizations** window.
- **Plot** or **Table** results: After completing the set up and performing the calculation, to view the matching name of the node on tab(s) in the **Visualizations** window, either click a **Plot Renderer** or **Table Renderer** node in the **Project** window or click the tabs individually in the **Visualizations** window.

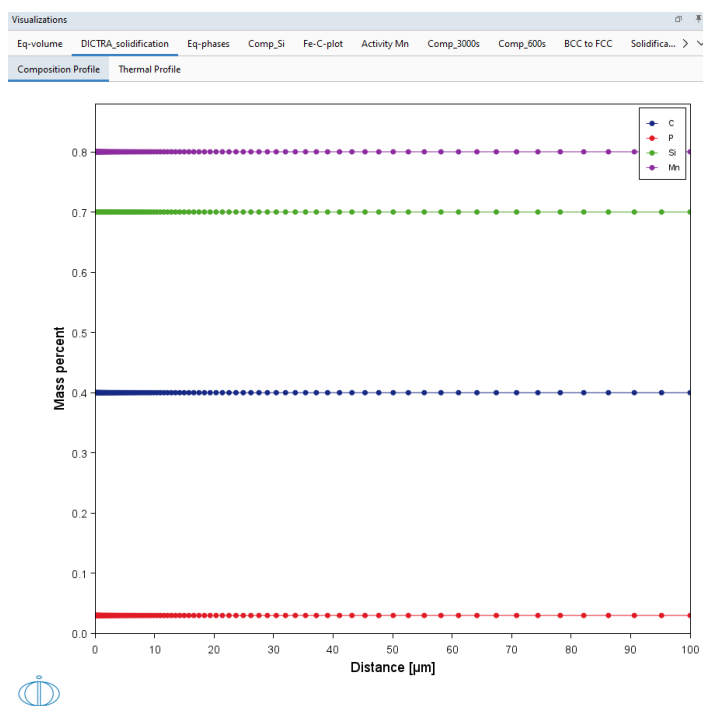

Figure 187: During set up of the calculation, you can preview the Composition Profile. Click the tab in the Visualizations window to switch between these previews and adjust settings on the Diffusion Calculator Configuration window.



The other resulting plots and details related to setting up this example are available to download via the [dedicated web page](#).

D_09: Ni Post Weld Heat Treatment

In this example, a Ni-based alloy (Ni-Al-Co-Cr-Mo-Ti) post weld heat treatment analysis is completed. It shows how to import an initial composition profile from a file into the Diffusion Calculator. Then the calculation is run and plotted to show the composition of Al vs distance compared to experimental data from [2017She]. Such simulations can be used to design the heat treatment such that the desired homogenization of the weld is achieved. The initial composition profile needs to be determined by suitable experimental techniques, for example microprobe.

This example highlights the dual purpose of the **Visualizations** window where you can enter or import *Composition profiles* via the Diffusion Calculator **Configuration** window as well as being able to view and analyze results via the Plot Renderer after a calculation runs.

Project File Information

- Folder: **Diffusion Module - DICTRA**
- File name: `D_09 Ni_Post_Weld_Heat_Treatment_From_File.tcu`

Visualizations



Many of our Graphical Mode examples have video tutorials, which you can access in a variety of ways. When in Thermo-Calc, from the menu select **Help** → **Video Tutorials**, or from the main My Project window, click **Video Tutorials**. Alternately, you can go to the [website](#) or our [YouTube channel](#).

Open the example project file to review the node setup on the **Project** window and the associated settings on the **Configuration** window for each node. For some types of projects, you can also adjust settings on the **Plot Renderer Configuration** window to preview results before performing the simulation. Click **Perform Tree** to generate plots and tables to see the results on the **Visualizations** window.

On the Diffusion Calculator, when defining its setup, the **Composition profiles** are imported using the **Table input** option. A prepared file, in this case a csv file, is set up with the correct data columns, which then are included on the **Configuration** window. After import the **Composition Profiles** are further able to be seen via the **Visualizations** window, at which point adjustments can be made as needed. In this isothermal example, you can also see that the constant temperature of the **Thermal Profile** is previewed.

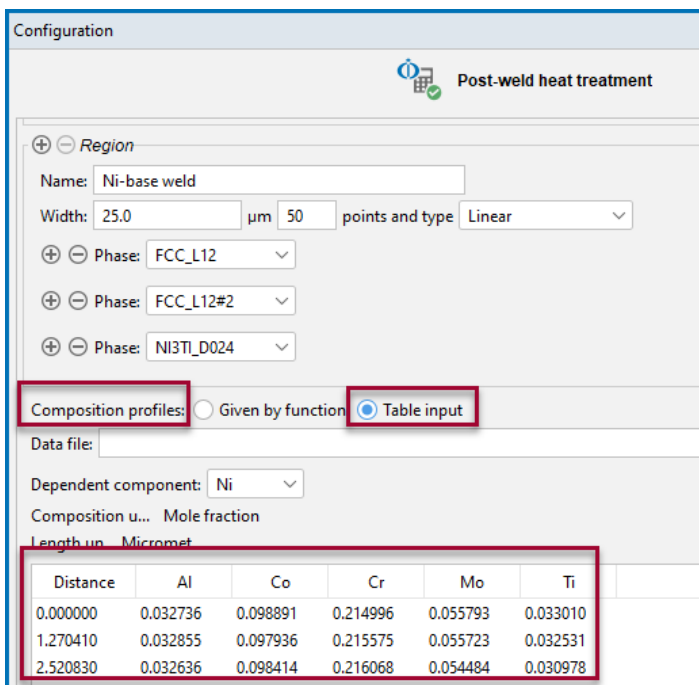

Figure 188: The Diffusion Calculator Configuration window showing the composition profile data, which is then compiled and displayed on the Visualizations window.

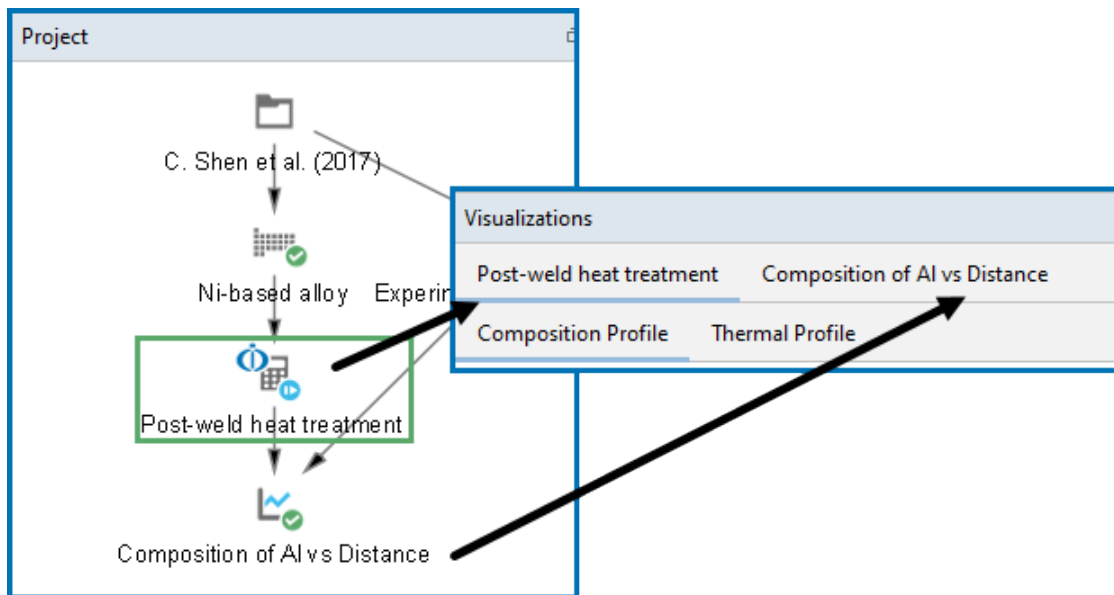

Figure 189: The Visualizations window displays details from both the Diffusion Calculator node (renamed to Post-weld heat treatment) via the Composition Profile and Thermal Profile tabs as well as the Plot Renderer node (renamed to Composition of Al vs Distance).

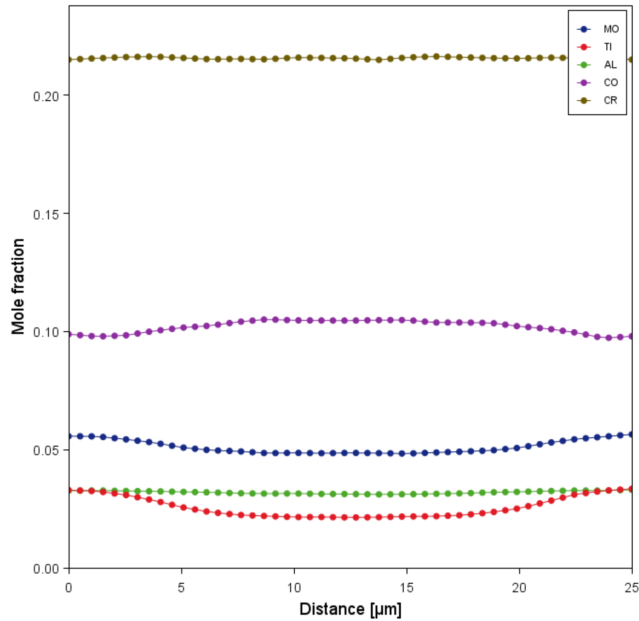

Figure 190: The Composition Profiles as shown in the Visualizations window after data is prepared and then imported into the Diffusion Calculator Configuration window.

An **Experimental File Reader** node is used to supply experimental data from [2017She] to the Plot Renderer to validate the composition of, for example, Al vs distance on the Plot Renderer. The plot shows the content of Al along the cross-section of the weld, both before and after the post weld heat treatment. There is good agreement between the diffusion simulation and the data measured in the literature.

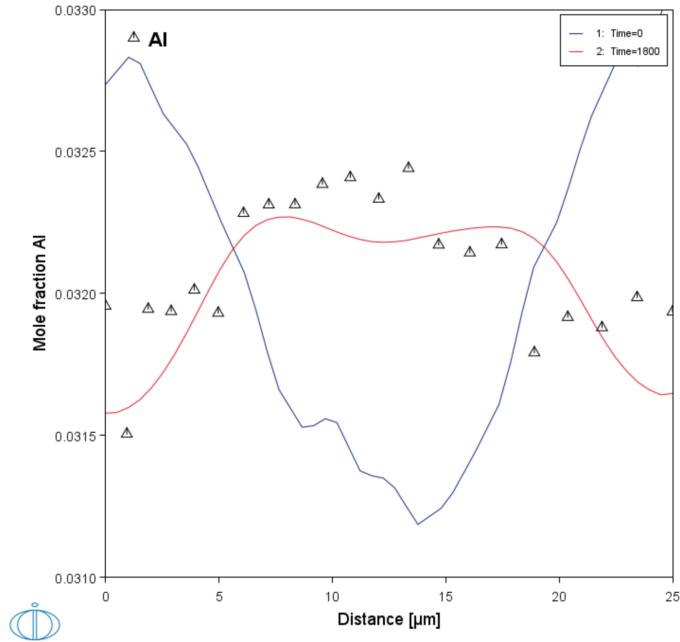

Figure 191: Plot results showing the mole fraction of Al before and after the heat treatment as a function of distance for a Ni-based alloy compared to experimental data [2017She].

Other plots can be added to investigate further details of the simulations, such as phase fractions or compositions.

Reference

[2017She] C. Shen, V. Gupta, S. Huang, M. Soare, P. Zhao, Y. Wang, “Modeling Long-term Creep Performance for Welded Nickel-base Superalloy Structures for Power Generation Systems” (Pittsburgh, PA, and Morgantown, WV (United States), 2017).

D_10: Iron (Fe) Homogenization in Scheil

This example models the homogenization of a cast Ni-Cr steel and compares predictions with the experimental data collated by Fuchs and Roósz [1975Fuc]. The conditions studied have a dendritic half spacing of 200 μm and are heat treated to temperatures of 1120 $^{\circ}\text{C}$ and 1235 $^{\circ}\text{C}$. The data has been un-normalized to allow comparison using wt.% composition values.

The composition of the steel is 0.4C, 0.65Mn, 0.35Si, 0.015S, 0.01P, 1.9Ni, 0.95Cr, and 0.3 Mo (wt.%). The diffusion of Cr and Ni are modeled using a simplified chemistry of 0.4C, 0.65Mn, 1.9Ni, and 0.95Cr.

Project File and License Information

- Folder: **Diffusion Module - DICTRA**
- File name: `D_10_Fe_Homogenization_from_Scheil.tcu`



The Diffusion Module (DICTRA) Console Mode example `exa7` is available to show the use of Scheil segregation profiles in Console Mode.



The FEDEMO thermodynamic and MFEDEMO mobility databases are used with this example. Users with a Diffusion Module (DICTRA) license can run the example. Other users can read the documentation as a DEMO license only allows the use of up to three components.

Visualizations



Many of our Graphical Mode examples have video tutorials, which you can access in a variety of ways. When in Thermo-Calc, from the menu select **Help** \rightarrow **Video Tutorials**, or from the main My Project window, click **Video Tutorials**. Alternately, you can go to the [website](#) or our [YouTube channel](#).

Open the example project file to review the node setup on the **Project** window and the associated settings on the **Configuration** window for each node. For some types of projects, you can also adjust settings on the **Plot Renderer Configuration** window to preview results before performing the simulation. Click **Perform Tree** to generate plots and tables to see the results on the **Visualizations** window.

There is a variety of information shown in the **Visualizations** window that can be viewed during configuration and after performing the calculation.

- **Composition Profiles and Thermal Profile:** When setting up a calculator on a **Configuration** window you can preview the profile and adjust settings as needed. When you click a calculator node in the **Project** window, the matching name of the node is on the tab(s) displayed in the **Visualizations** window.
- **Plot or Table results:** After completing the set up and performing the calculation, to view the matching name of the node on tab(s) in the **Visualizations** window, either click a **Plot Renderer** or **Table Renderer** node in the **Project** window or click the tabs individually in the **Visualizations** window.

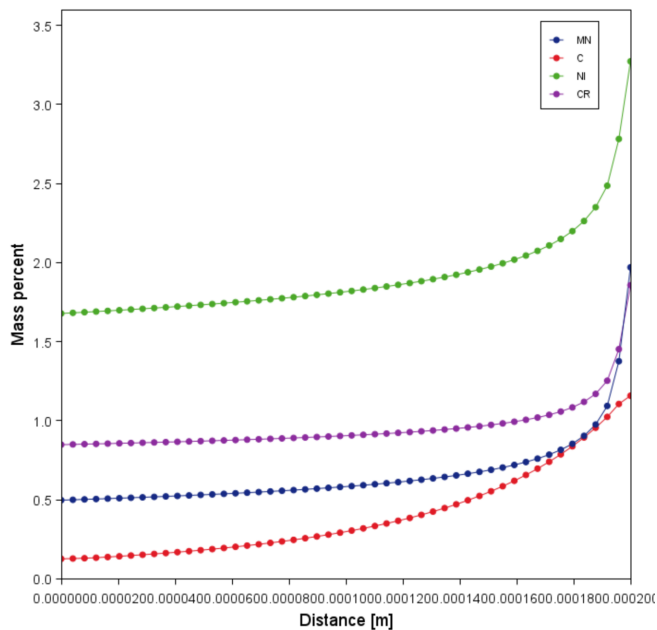

Figure 192: The predicted chemical segregation using the Scheil calculation, with a dendritic half spacing of 200 μm . This is the Composition Profile that is set up on the Diffusion Calculator and then previewed in the Visualizations window.

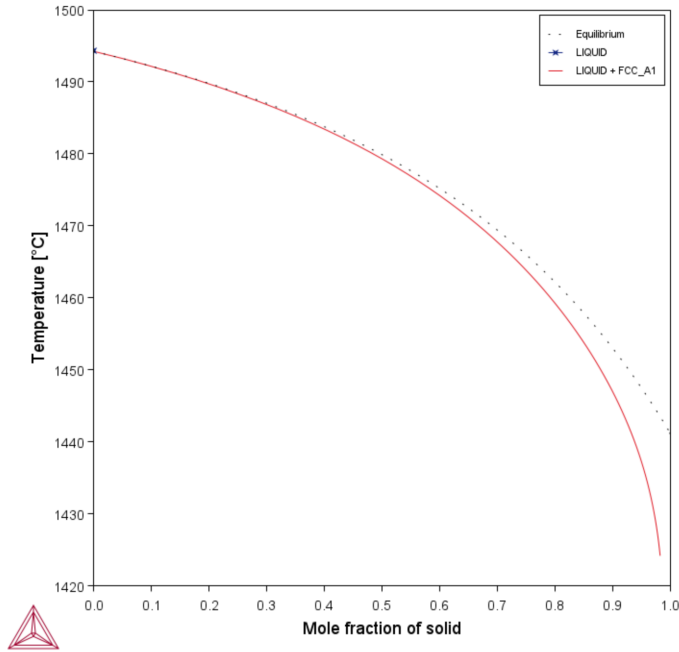

Figure 193: The solidification behavior predicted from the Scheil calculation compared with the equilibrium solid fraction.

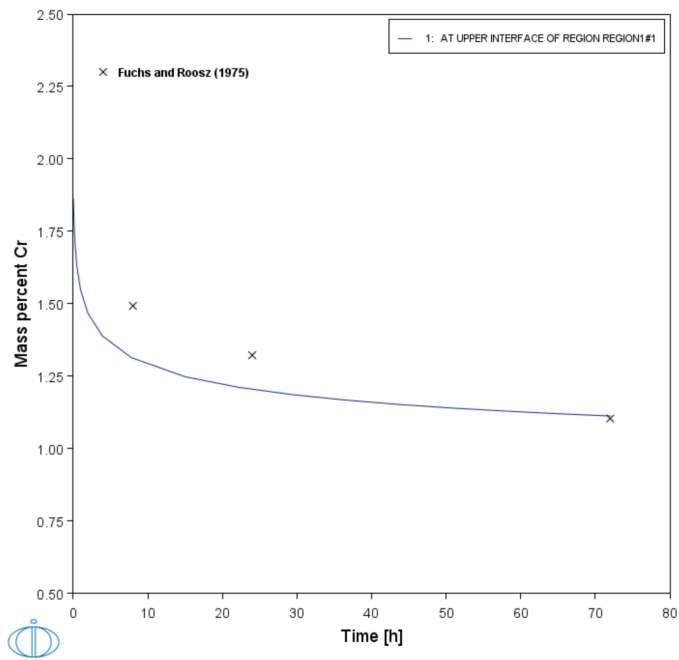

Figure 194: A comparison of the predicted and measured maximum Cr across the dendrites during homogenization at 1120 °C.

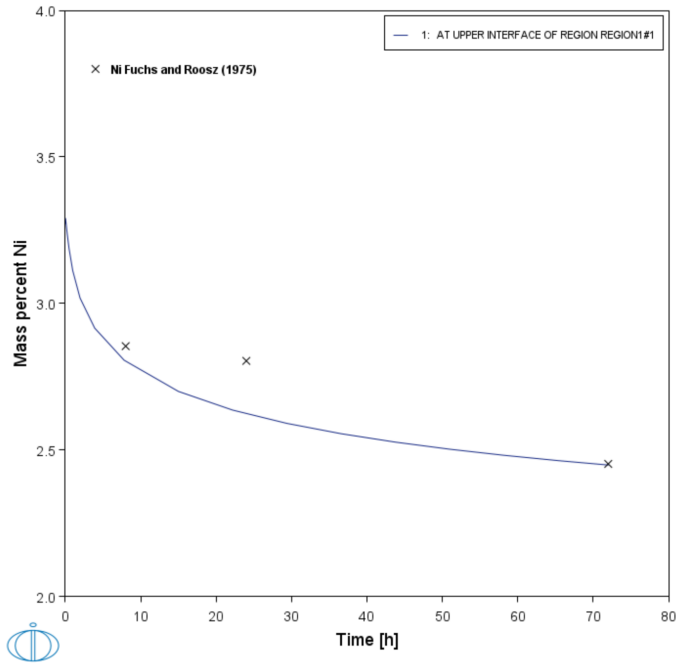

Figure 195: A comparison of the predicted and measured maximum Ni across the dendrites during homogenization at 1120 °C.

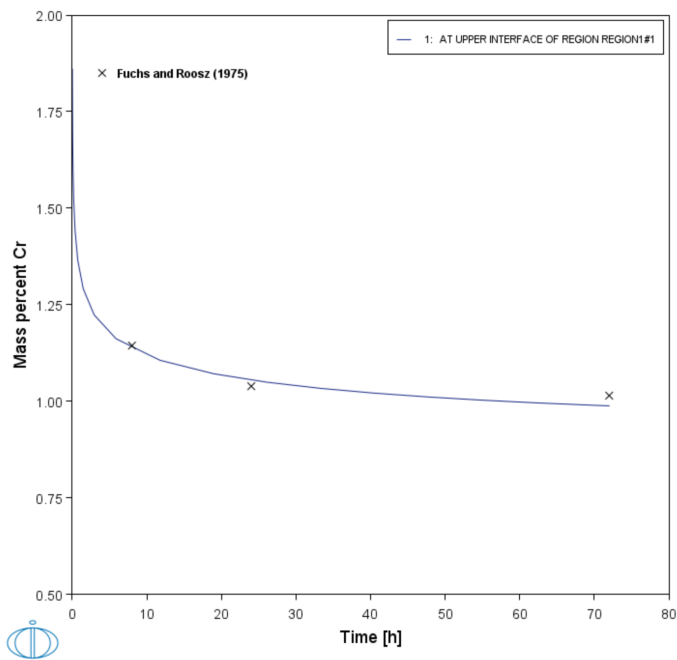

Figure 196: A comparison of the predicted and measured maximum Cr across the dendrites during homogenization at 1235 °C.

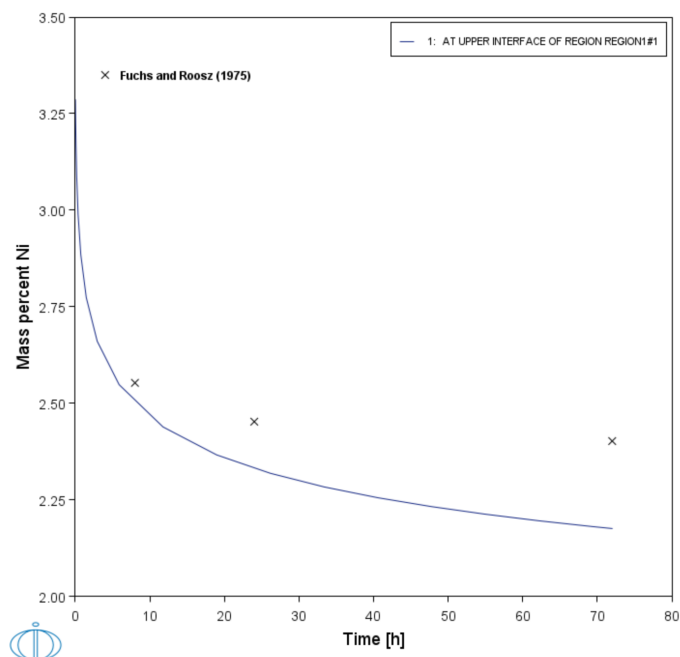

Figure 197: A comparison of the predicted and measured maximum Ni across the dendrites during homogenization at 1235 °C.

Reference

[1975Fuc] E. G. Fuchs, A. Roósz, Homogenization of Iron-Base Cast Alloys. *Met. Sci.* 9, 111–118 (1975).

Precipitation Module (TC-PRISMA) Examples Collection



Examples that use up to three elements are available to all users. Other examples require a Precipitation Module (TC-PRISMA) license to calculate and plot results.



When an example uses a demonstration (demo) database package, this is included with your installation.



Unless specified in tables for each example, all the numerical parameters are assumed default values.

In this section:

P_01: Isothermal Precipitation of Al3Sc	276
P_02: Stable and Metastable Carbides - Isothermal	281
P_03: Stable and Metastable Carbides - TTT Diagram	285
P_04: Precipitation of Iron Carbon Cementite	289
P_05: Precipitation of γ' in Ni Superalloys - Isothermal	292
P_06: Precipitation of γ' in Ni Superalloys - Non-isothermal	297
P_07: Continuous Cooling Transformation (CCT) Diagram of Ni-Al-Cr γ - γ'	305
P_08: Precipitation of Cu-Ti CU4TI with Assumptions of Sphere and Needle Morphologies	308
P_09: Precipitation of Al-Sc AL3SC with Assumption of Sphere and Cuboid Morphologies	314
P_10: Initial Particle Size Distribution of Fe-Cr-C	320
P_11: Interfacial Energy Function	327
P_12: Comparing Growth Rate Models for an Al-Zr System	330
P_13: Paraequilibrium Precipitation of Cementite Fe-C-Cr	334

P_14: Grain Growth and the Zener Pinning Effect	337
P_15: Smooth Transition from Paraequilibrium to Ortho-equilibrium	341
P_16 Isothermal Coarsening and a 3D to 2D Stereological Conversion	346

P_01: Isothermal Precipitation of Al₃Sc

This example simulates the kinetics of precipitation of Al₃Sc from an FCC_A1 solution phase. The simulation results can be compared with experimental data collected from Marquis and Seidman [2001Mar] and Novotny and Ardell [2001Nov].

This example also includes a plot using the **Yield strength** Property Model. This demonstrates how you can use the results from a Precipitation Module (TC-PRISMA) simulation as input to the Yield Strength Model, i.e. the calculated precipitate radius/radii for each time step is used to calculate the precipitation strengthening, and similarly, the matrix composition for each time step is used to calculate the solid solution strengthening when this is selected in the **Configuration** on the Plot Renderer. The experimental data for the Yield Strength Model is from Seidman et al. [2002Sei]. In this example, the *Precipitation strengthening model* used is **Seidman model (Al-base)**. This is selected on the Plot Renderer configuration panel that is connected to the Property Model.

Project File and Step-By Step Instructions

- Folder: **Precipitation Module - TC-PRISMA**
- File name: P_01_Precipitation_Al-Sc_AL3SC.tcus

Example Settings

System (System Definer)	
Database package	Demo: Aluminum-based alloys (ALDEMO, MALDEMO)
Elements	Al, Sc
Conditions (Precipitation Calculator)	
Composition	Al-0.18Sc Mole percent
Matrix phase	FCC_A1
Precipitate phase	AL3SC
Precipitate Phase Data Parameters (Precipitation Calculator)	
Nucleation sites	Bulk

Interfacial energy	Calculated
Calculation Type (Precipitation Calculator)	
Calculation type	Isothermal
Temperature	350° C
Simulation time	1.0E7 seconds
Experimental File Reader 1 and 2	
There are two Experimental File Reader nodes used. One for the mean radius plot and one to demonstrate the <i>Yield Strength Property Model</i> .	

Visualizations



This example is included as a Precipitation Module (TC-PRISMA) tutorial on our [website](#) and as part of the playlist on our [YouTube channel](#).

Open the example project file to review the node setup on the **Project** window and the associated settings on the **Configuration** window for each node. For some types of projects, you can also adjust settings on the **Plot Renderer Configuration** window to preview results before performing the simulation. Click **Perform Tree** to generate plots and tables to see the results on the **Visualizations** window.

There is a variety of information shown in the **Visualizations** window that can be viewed during configuration and after performing the calculation.

- **Thermal Profile:** When setting up a calculator on a **Configuration** window for **Isothermal** or **Non-isothermal Calculation Types**, you can preview the profile and adjust settings as needed. When you click a calculator node in the **Project** window, the matching name of the node is on the tab(s) displayed in the **Visualizations** window.



For **TTT Diagram** and **CCT Diagram** calculations there is nothing shown for the Precipitation Calculator tab in the **Visualizations** window as there is no Thermal Profile to be defined.

- **Plot or Table** results: After completing the set up and performing the calculation, to view the matching name of the node on tab(s) in the **Visualizations** window, either click a **Plot Renderer** or **Table Renderer** node in the **Project** window or click the tabs individually in the **Visualizations** window.

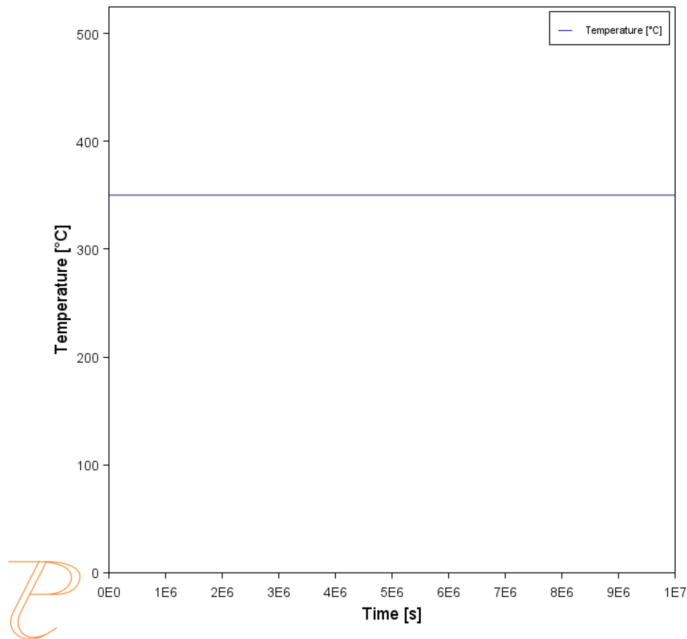
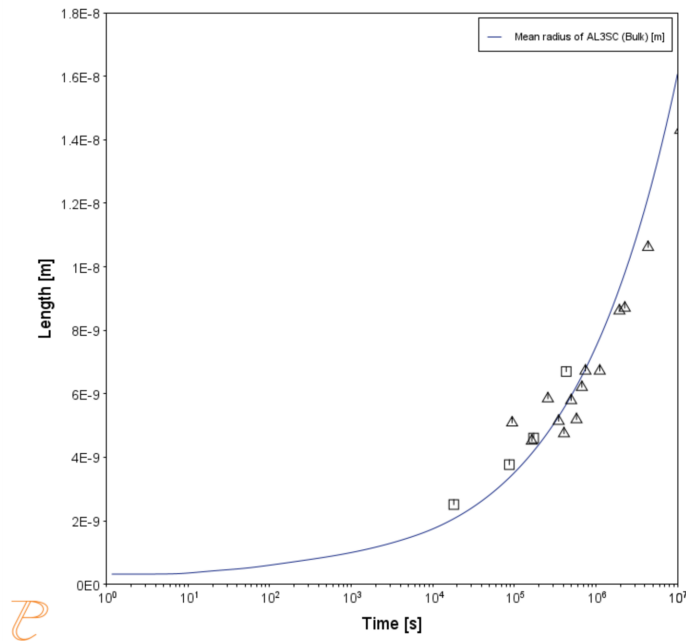

Figure 198: During set up of the calculation, preview the Thermal Profile. Click the tab in the Visualizations window to preview it. For an Isothermal Thermal Profile this shows the constant temperature as entered.



P

Figure 199: After performing the calculation, you can view the result on the applicable tab. This plot shows the mean radius of the AL3SC precipitate as a function of time.

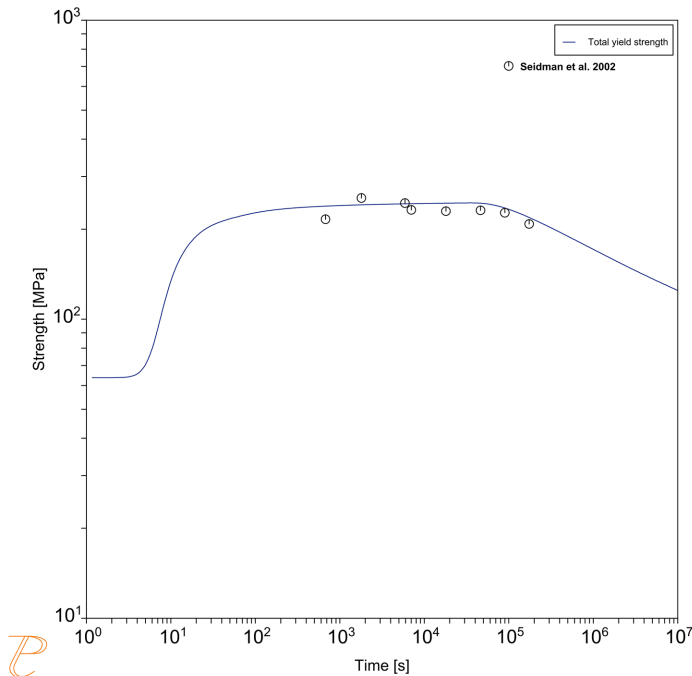

Figure 200: After performing the calculation, you can view the result on the applicable tab. This plot shows the total yield strength of the Al₃Sc precipitate as a function of time compared to experimental data from Seidman et al. [2002Sei]. The model captures the over-tempering behavior from excessive coarsening of the strengthening precipitates.

References

- [2001Mar] E. A. Marquis, D. N. Seidman, Nanoscale structural evolution of Al₃Sc precipitates in Al(Sc) alloys. *Acta Mater.* 49, 1909–1919 (2001).
- [2001Nov] G. M. Novotny, A. J. Ardell, Precipitation of Al₃Sc in binary Al–Sc alloys. *Mater. Sci. Eng. A Struct. Mater. Prop. Microstruct. Process.* 318, 144–154 (2001).
- [2002Sei] D. N. Seidman, E. A. Marquis, D. C. Dunand, Precipitation strengthening at ambient and elevated temperatures of heat-treatable Al(Sc) alloys. *Acta Mater.* 50, 4021–4035 (2002).

P_02: Stable and Metastable Carbides - Isothermal

This example simulates the kinetics of precipitation of both stable and metastable carbides from ferrite phase. It demonstrates that metastable carbides (cementite, M7C3) may first emerge and then disappear and the stable phase (M23C6) prevails.

This example uses the Equilibrium Calculator and a one axis calculation to determine how the phases change with temperature. We are interested in the carbide precipitation at 1053 K where only the carbide M23C6 is stable according to the equilibrium calculation. The Precipitation Calculator is used to do an isothermal calculation of the three phases (cementite, M23C6, and M7C3) where cementite and M7C3 are metastable phases.

Project File Information

- Folder: **Precipitation Module - TC-PRISMA**
- File name: P_02_Precipitation_Fe-C-Cr_Cementite-M7C3-M23C6.tcu

Example Settings

System (System Definer)	
Database package	Demo: Steels and Fe-alloys (FEDEMO,MFEDEMO)
Elements	Fe, C, Cr
Conditions (Precipitation Calculator)	
Composition	Fe-0.1C-12Cr Mass percent
Matrix phase	BCC_A2
Precipitate phases	Cementite, M23C6 and M7C3
Matrix Phase Data Parameters (Precipitation Calculator)	
Grain size (click Show Details to display this setting)	1.0E-4 m
Precipitate Phase Data Parameters (Precipitation Calculator)	
Nucleation sites	Grain boundaries

Interfacial energy	Cementite 0.167 J/m ² , M23C6 0.252 J/m ² , M7C3 0.282 J/m ²
Calculation Type (Precipitation Calculator)	
Calculation type	Isothermal
Temperature	1053 K
Simulation time	400 000 seconds

Visualizations



Many of our Graphical Mode examples have video tutorials, which you can access in a variety of ways. When in Thermo-Calc, from the menu select **Help** → **Video Tutorials**, or from the main My Project window, click **Video Tutorials**. Alternately, you can go to the [website](#) or our [YouTube channel](#).

Open the example project file to review the node setup on the **Project** window and the associated settings on the **Configuration** window for each node. For some types of projects, you can also adjust settings on the **Plot Renderer Configuration** window to preview results before performing the simulation. Click **Perform Tree** to generate plots and tables to see the results on the **Visualizations** window.

There is a variety of information shown in the **Visualizations** window that can be viewed during configuration and after performing the calculation.

- **Thermal Profile:** When setting up a calculator on a **Configuration** window for **Isothermal** or **Non-isothermal Calculation Types**, you can preview the profile and adjust settings as needed. When you click a calculator node in the **Project** window, the matching name of the node is on the tab(s) displayed in the **Visualizations** window.



For **TTT Diagram** and **CCT Diagram** calculations there is nothing shown for the Precipitation Calculator tab in the **Visualizations** window as there is no Thermal Profile to be defined.

- **Plot or Table** results: After completing the set up and performing the calculation, to view the matching name of the node on tab(s) in the **Visualizations** window, either click a **Plot Renderer** or **Table Renderer** node in the **Project** window or click the tabs individually in the **Visualizations** window.



For this **Isothermal** example, its **Thermal Profile** is also displayed in the **Visualizations** window showing the constant temperature entered for this calculation type. The tab names match the node names in the **Project** window.

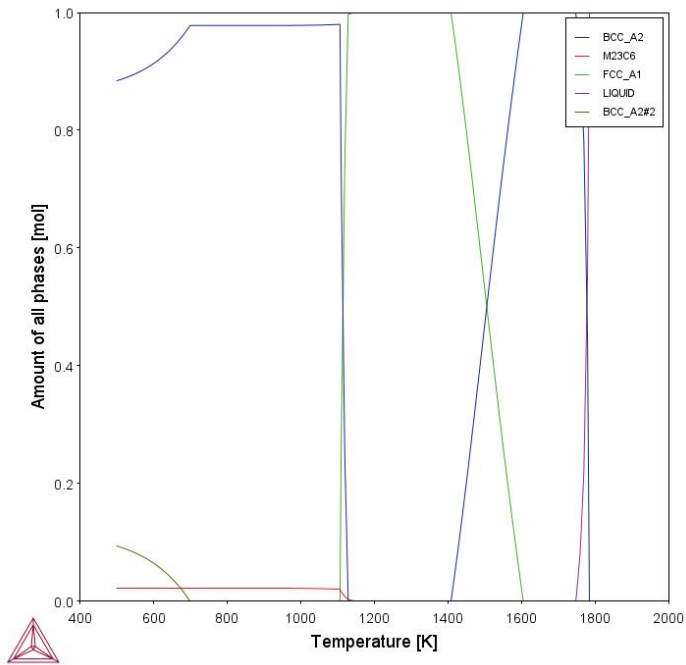

Figure 201: After performing the calculation, you can view the result on the applicable tab. This shows the equilibrium property diagram for the Fe-C-Cr alloy, highlighting what phases are predicted to be at equilibrium for a range of temperatures. The calculation shows that at 1053 K, M23C6 is the stable carbide.

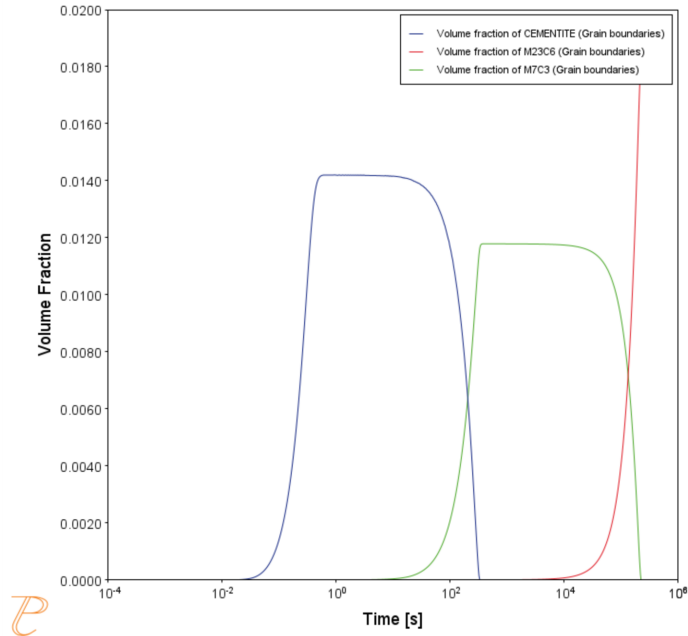

Figure 202: After performing the calculation, you can view the result on the applicable tab. This shows the evolution of the volume fraction of cementite, M7C3, and M23C6 during an isothermal heat treatment of an Fe-C-Cr alloy at 1073 K. The cementite and M7C3 are metastable at this temperature, however their nucleation kinetics are faster than the stable phase, allowing them to form and then dissolve when the next more thermodynamically stable phase nucleates.

P_03: Stable and Metastable Carbides - TTT Diagram

In this example, the kinetics of precipitation of both stable and metastable carbides is calculated from the ferrite phase. It demonstrates that metastable carbides may first emerge and then disappear and the stable phase prevails.

This example uses the Equilibrium Calculator and a one axis calculation type to determine how the phases change with temperature. Using this result, the Precipitation Calculator is used to do a TTT (Time-Temperature-Transformation) diagram calculation of the three phases (cementite, M23C6 and M7C3) at the grain boundaries.

For a TTT diagram calculation, select **TTT diagram** in **Calculation Type**, then enter **Min**, **Max**, and **Step of Temperature**, as well as **Max annealing time**. In **Stop criterion**, choose **Volume fraction of phase** and enter the value.

Project File Information

- Folder: **Precipitation Module - TC-PRISMA**
- File name: `P_03_Precipitation_Fe-C-Cr_TTT_Cementite-M7C3-M23C6.tcu`

Example Settings

System (System Definer)	
Database package	Demo: Steels and Fe-alloys (FEDEMO and MFEDEMO)
Elements	Fe, C, Cr
Conditions (Precipitation Calculator)	
Composition	Fe-0.1C-12Cr Mass percent
Matrix phase	BCC_A2

Precipitate phases	Cementite, M23C6 and M7C3
Matrix Phase Data Parameters (Precipitation Calculator)	
Grain size (click Show Details to display this setting)	1.0E-4 m
Precipitate Phase Data Parameters	
Nucleation sites	Grain boundaries
Interfacial energy	Cementite 0.167 J/m ² , M23C6 0.252 J/m ² , M7C3 0.282 J/m ²
Calculation Type (Precipitation Calculator)	
Calculation type	TTT diagram
Temperature	500° to 800° C with 25° C steps
Max. annealing time	1.0E8 seconds
Stop criteria	Volume fraction of phase is set to 0.0001
Options > Numerical Parameters	
No. of grid points over one order of magnitude in radius	150
Max no. of grid points over one order of magnitude in radius	200
Min no. of grid points over one order of magnitude in radius	100

Visualizations



Many of our Graphical Mode examples have video tutorials, which you can access in a variety of ways. When in Thermo-Calc, from the menu select **Help** → **Video Tutorials**, or from the main My Project window, click **Video Tutorials**. Alternately, you can go to the [website](#) or our [YouTube channel](#).

Open the example project file to review the node setup on the **Project** window and the associated settings on the **Configuration** window for each node. For some types of projects, you can also adjust settings on the **Plot Renderer Configuration** window to preview results before performing the simulation. Click **Perform Tree** to generate plots and tables to see the results on the **Visualizations** window.

There is a variety of information shown in the **Visualizations** window that can be viewed during configuration and after performing the calculation.

- **Thermal Profile:** When setting up a calculator on a **Configuration** window for **Isothermal** or **Non-isothermal Calculation Types**, you can preview the profile and adjust settings as needed. When you click a calculator node in the **Project** window, the matching name of the node is on the tab(s) displayed in the **Visualizations** window.



For **TTT Diagram** and **CCT Diagram** calculations there is nothing shown for the Precipitation Calculator tab in the **Visualizations** window as there is no Thermal Profile to be defined.

- **Plot or Table** results: After completing the set up and performing the calculation, to view the matching name of the node on tab(s) in the **Visualizations** window, either click a **Plot Renderer** or **Table Renderer** node in the **Project** window or click the tabs individually in the **Visualizations** window.

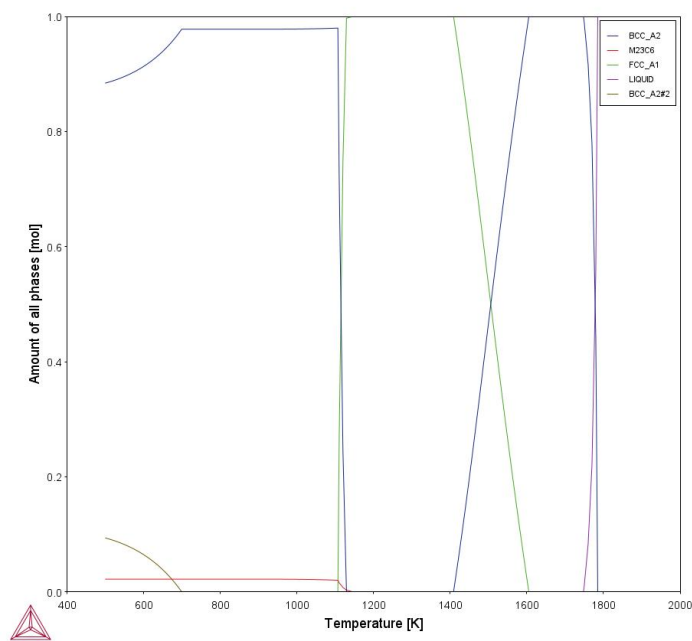

Figure 203: After performing the calculation, you can view the result on the applicable tab. Here the results from the equilibrium calculator are shown, which assesses the stability of phases across the temperature range of interest.

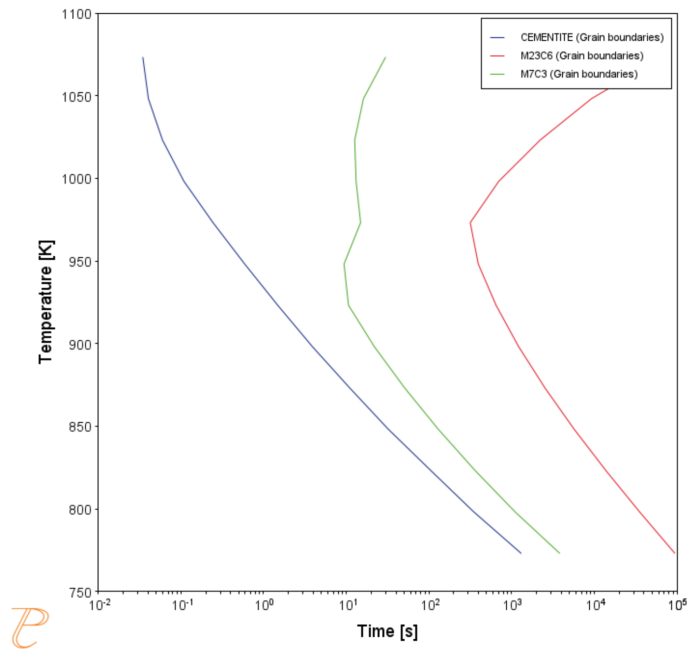

Figure 204: After performing the calculation, you can view the result on the applicable tab. This shows results from a TTT (Temperature-Transformation) simulation using the Precipitation Calculator to examine the sequence of phase transitions considering the formation of cementite, M7C3, and M23C6 carbide phases. The previous Equilibrium Calculator reveals the temperatures where the cementite and M7C3 are metastable.

P_04: Precipitation of Iron Carbon Cementite

This example is based on [1949Wer] and simulates the kinetics of precipitation of carbides from a BCC Fe solution phase. This isothermal calculation example uses the Precipitation Calculator plus two Experimental File Reader activities to plot the volume fraction of the cementite phase.

Project File Information

- Folder: **Precipitation Module - TC-PRISMA**
- File name: P_04_Precipitation_Fe-C_Cemetite.tcu

Example Settings

System (System Definer)	
Database package	Demo: Steels and Fe-alloys (FEDEMO and MFEDEMO)
Elements	Fe, C
Conditions (Precipitation Calculator)	
Composition	Fe-0.016C mass percent
Matrix phase	BCC_A2
Precipitate phase	Cementite
Matrix Phase Data Parameters (Precipitation Calculator)	
Grain aspect ratio (click Show Details to display this setting)	1.0
Dislocation density (click Show Details to display this setting)	$1.5e11\text{m}^{-3}$
Precipitate Phase Parameters (Precipitation Calculator)	
Nucleation sites	Dislocations
Interfacial energy	0.24 J/m^2

Growth rate model (click Show Details)	Advanced
Calculation Type (Precipitation Calculator)	
Calculation type	Isothermal
Temperature	102° C
Simulation time	600 000 seconds

Visualizations



Many of our Graphical Mode examples have video tutorials, which you can access in a variety of ways. When in Thermo-Calc, from the menu select **Help → Video Tutorials**, or from the main My Project window, click **Video Tutorials**. Alternately, you can go to the [website](#) or our [YouTube channel](#).

Open the example project file to review the node setup on the **Project** window and the associated settings on the **Configuration** window for each node. For some types of projects, you can also adjust settings on the **Plot Renderer Configuration** window to preview results before performing the simulation. Click **Perform Tree** to generate plots and tables to see the results on the **Visualizations** window.



When you run (Perform) this example, it takes a few minutes for the calculations to complete.

There is a variety of information shown in the **Visualizations** window that can be viewed during configuration and after performing the calculation.

- **Thermal Profile:** When setting up a calculator on a **Configuration** window for **Isothermal** or **Non-isothermal Calculation Types**, you can preview the profile and adjust settings as needed. When you click a calculator node in the **Project** window, the matching name of the node is on the tab(s) displayed in the **Visualizations** window.



For **TTT Diagram** and **CCT Diagram** calculations there is nothing shown for the Precipitation Calculator tab in the **Visualizations** window as there is no Thermal Profile to be defined.

- **Plot** or **Table** results: After completing the set up and performing the calculation, to view the matching name of the node on tab(s) in the **Visualizations** window, either click a **Plot Renderer** or **Table Renderer** node in the **Project** window or click the tabs individually in the **Visualizations** window.



For this **Isothermal** example, its **Thermal Profile** is also displayed in the **Visualizations** window showing the constant temperature entered for this calculation type. The tab names match the node names in the **Project** window.

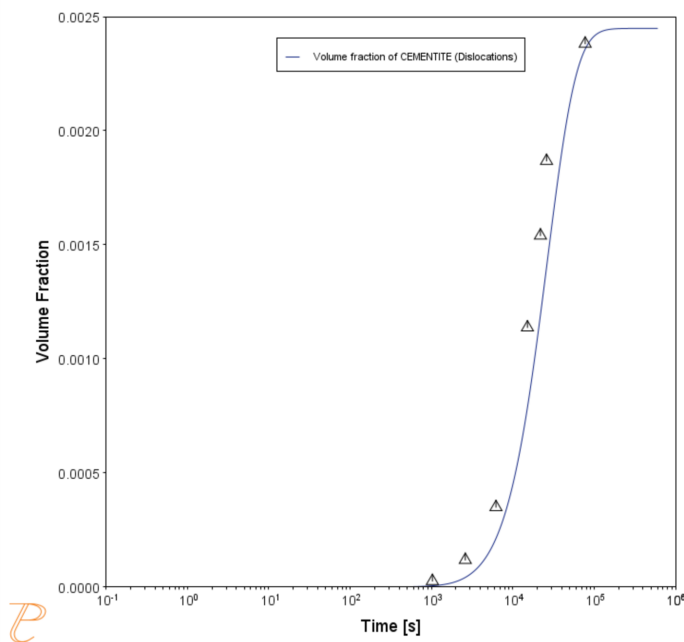

Figure 205: After performing the calculation, you can view the result on the applicable tab. The result compares the predicted evolution of the volume fraction of cementite with the measurements of [1949Wer].

Reference

[1949Wer] C. A. Wert, Precipitation from Solid Solutions of C and N in α -Iron. J. Appl. Phys. 20, 943 (1949).

P_05: Precipitation of γ' in Ni Superalloys - Isothermal

This example simulates the kinetics of precipitation of gamma prime (γ') phase from gamma (γ) phase. The simulation results can be compared with experimental data collected from Sudbrack et al. [2008Sud].

This example uses three Experimental File Reader activities with the Precipitation Calculator. It does an isothermal calculation to plot the volume fraction, mean radius, and number density of the cementite phase.



DIS_FCC_A1 needs to be selected on the System Definer.

Project File Information

- Folder: **Precipitation Module - TC-PRISMA**
- File name: P_05_Precipitation_Ni-Al-Cr_Isothermal_Gamma-Gamma_prime.tcu

Example Settings

System (System Definer)	
Database package	Demo: Nickel-based Super Alloys (NIDEMO and MNIDEMO)
Elements	Ni, Al Cr
Conditions (Precipitation Calculator)	
Composition	Ni-9.8Al-8.3Cr Mole percent
Matrix phase	DIS-FCC_A1
Precipitate phase	FCC_L12#2
Precipitate Phase Data Parameters (Precipitation Calculator)	
Nucleation sites	Bulk

Interfacial energy	0.012 J/m ²
Calculation Type (Precipitation Calculator)	
Calculation type	Isothermal
Temperature	800° C
Simulation time	1 000 000 seconds

Visualizations



Many of our Graphical Mode examples have video tutorials, which you can access in a variety of ways. When in Thermo-Calc, from the menu select **Help → Video Tutorials**, or from the main My Project window, click **Video Tutorials**. Alternately, you can go to the [website](#) or our [YouTube channel](#).

Open the example project file to review the node setup on the **Project** window and the associated settings on the **Configuration** window for each node. For some types of projects, you can also adjust settings on the **Plot Renderer Configuration** window to preview results before performing the simulation. Click **Perform Tree** to generate plots and tables to see the results on the **Visualizations** window.

There is a variety of information shown in the **Visualizations** window that can be viewed during configuration and after performing the calculation.

- **Thermal Profile:** When setting up a calculator on a **Configuration** window for **Isothermal** or **Non-isothermal Calculation Types**, you can preview the profile and adjust settings as needed. When you click a calculator node in the **Project** window, the matching name of the node is on the tab(s) displayed in the **Visualizations** window.



For **TTT Diagram** and **CCT Diagram** calculations there is nothing shown for the Precipitation Calculator tab in the **Visualizations** window as there is no Thermal Profile to be defined.

- **Plot or Table** results: After completing the set up and performing the calculation, to view the matching name of the node on tab(s) in the **Visualizations** window, either click a **Plot Renderer** or **Table Renderer** node in the **Project** window or click the tabs individually in the **Visualizations** window.



For this **Isothermal** example, its **Thermal Profile** is also displayed in the **Visualizations** window showing the constant temperature entered for this calculation type. The tab names match the node names in the **Project** window.

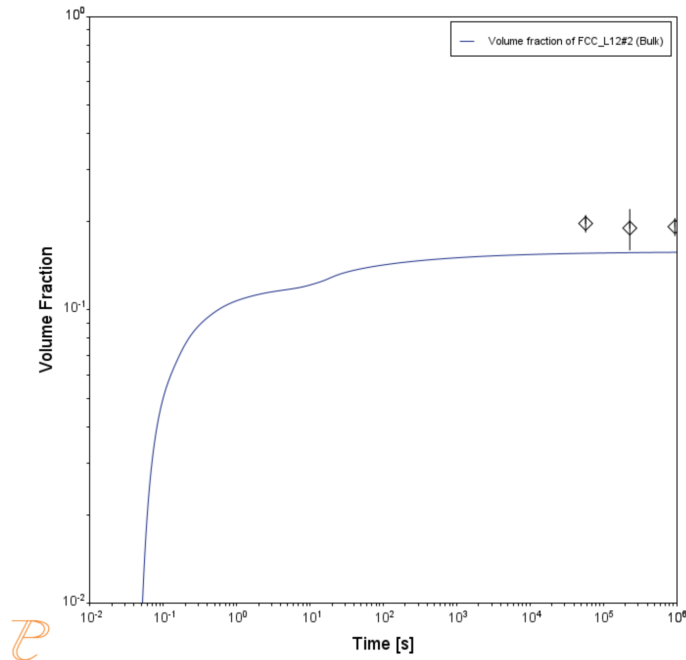

Figure 206: After performing the calculation, you can view the result on the applicable tab. This plot compares the predicted evolution of the volume fraction of gamma prime with the measurements of [2008Sud].

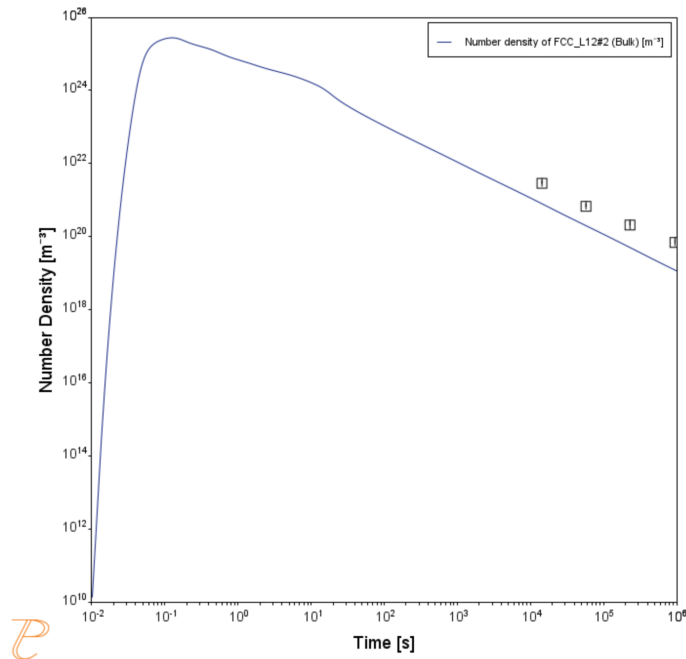

Figure 207: After performing the calculation, you can view the result on the applicable tab. This plot compares the predicted evolution of the number density of gamma prime with the measurements of [2008Sud].

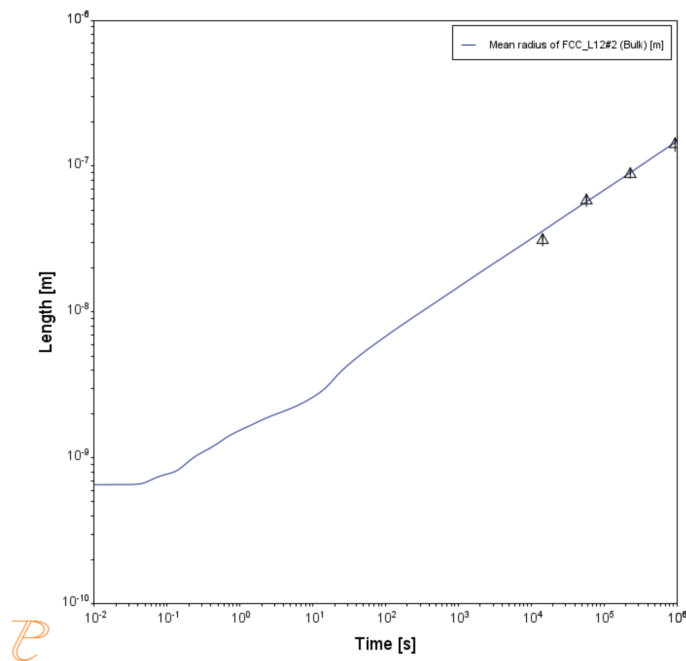

Figure 208: After performing the calculation, you can view the result on the applicable tab. This plot compares the predicted evolution of the mean particle radius of gamma prime with the measurements of [2008Sud].

Reference

[2008Sud] C. K. Sudbrack, T. D. Ziebell, R. D. Noebe, D. N. Seidman, Effects of a tungsten addition on the morphological evolution, spatial correlations and temporal evolution of a model Ni–Al–Cr superalloy. *Acta Mater.* 56, 448–463 (2008).

P_06: Precipitation of γ' in Ni Superalloys - Non-isothermal

This example simulates the kinetics of precipitation of gamma prime (γ') phase from gamma (γ) phase in Ni-8Al-8Cr and Ni-10Al-10Cr at.% alloys during continuous cooling from a super-solvus temperature. The simulation results can be compared with experimental results from Rojhirunsakool et al. [2013Roj].



DIS_FCC_A1 needs to be selected on the **System Definer** for both the thermodynamic and mobility databases.

Project File Information

- Folder: **Precipitation Module - TC-PRISMA**
- File name: P_06_Precipitation_Ni-Al-Cr_Non-isothermal_Gamma-Gamma_prime.tcu

Example Settings

System (System Definer)	
Database package	Demo: Nickel-based Super Alloys (NIDEMO and MNIDEMO)
Elements	Ni, Al, Cr
Conditions (Precipitation Calculator)	
Composition (Ni-8Al-8Cr)	Ni-8Al-8Cr Mole percent
Composition (Ni-10Al-10Cr)	Ni-10Al-10Cr Mole percent
Matrix phase	DIS_FCC_A1

Precipitate phase	FCC_L12#2						
Matrix Phase Data Parameters (Precipitation Calculator)							
Mobility adjustment > Prefactor (click Show Details to display this setting)	Keep the default, Same for all elements, then enter 5.0 for the Prefactor.						
Precipitate Phase Data Parameters (Precipitation Calculator)							
Nucleation sites	Bulk						
Interfacial energy	0.023 J/m ²						
Calculation Type (Precipitation Calculator)							
Calculation type	Non-isothermal						
Temperature unit	Celsius						
Time unit	Seconds						
Temperature	<p>1150 - 380 °C</p> <p>Edit Thermal Profile</p> <div style="border: 1px solid #ccc; padding: 5px; margin-bottom: 5px;"> <input type="button" value="Import..."/> </div> <table border="1" style="width: 100%; border-collapse: collapse;"> <thead> <tr> <th style="width: 50%;">Time [s]</th> <th style="width: 50%;">Temperature [°C]</th> </tr> </thead> <tbody> <tr> <td>0.0</td> <td>1150.0</td> </tr> <tr> <td>3300.0</td> <td>380.0</td> </tr> </tbody> </table>	Time [s]	Temperature [°C]	0.0	1150.0	3300.0	380.0
Time [s]	Temperature [°C]						
0.0	1150.0						
3300.0	380.0						
Simulation time (Ni-8Al-8Cr)	3300 s						
Simulation time (Ni-10Al-10Cr)	3300 s						
Multimodal PSD (Plot Renderer)							
Separate multimodal PSD checkbox is selected for 8Al-8Cr for both the Mean radius and PSD plots.	<ul style="list-style-type: none"> • Mean Radius and PSD plots: The Inflection neighbors and Smoothing interactions defaults are kept. • Mean Radius plot: The Points are set to 15. 						
Separate multimodal PSD checkbox is selected for 10Al-10Cr for both the Mean radius and PSD plots.	<ul style="list-style-type: none"> • Mean Radius and PSD plots: The Inflection neighbors and Smoothing interactions defaults are 						

kept.

- Mean Radius plot: The **Points** are set to 50.

Visualizations



Many of our Graphical Mode examples have video tutorials, which you can access in a variety of ways. When in Thermo-Calc, from the menu select **Help → Video Tutorials**, or from the main My Project window, click **Video Tutorials**. Alternately, you can go to the [website](#) or our [YouTube channel](#).

Open the example project file to review the node setup on the **Project** window and the associated settings on the **Configuration** window for each node. For some types of projects, you can also adjust settings on the **Plot Renderer Configuration** window to preview results before performing the simulation. Click **Perform Tree** to generate plots and tables to see the results on the **Visualizations** window.



When you run (Perform) this example, it takes a few minutes for the calculations to complete.

There is a variety of information shown in the **Visualizations** window that can be viewed during configuration and after performing the calculation.

- **Thermal Profile:** When setting up a calculator on a **Configuration** window for **Isothermal** or **Non-isothermal Calculation Types**, you can preview the profile and adjust settings as needed. When you click a calculator node in the **Project** window, the matching name of the node is on the tab(s) displayed in the **Visualizations** window.



For **TTT Diagram** and **CCT Diagram** calculations there is nothing shown for the Precipitation Calculator tab in the **Visualizations** window as there is no Thermal Profile to be defined.

- **Plot or Table** results: After completing the set up and performing the calculation, to view the matching name of the node on tab(s) in the **Visualizations** window, either click a **Plot Renderer** or **Table Renderer** node in the **Project** window or click the tabs individually in the **Visualizations** window.



In this example, all nodes are renamed in the **Project** window, and this matches each of the tab names in the **Visualizations** window.

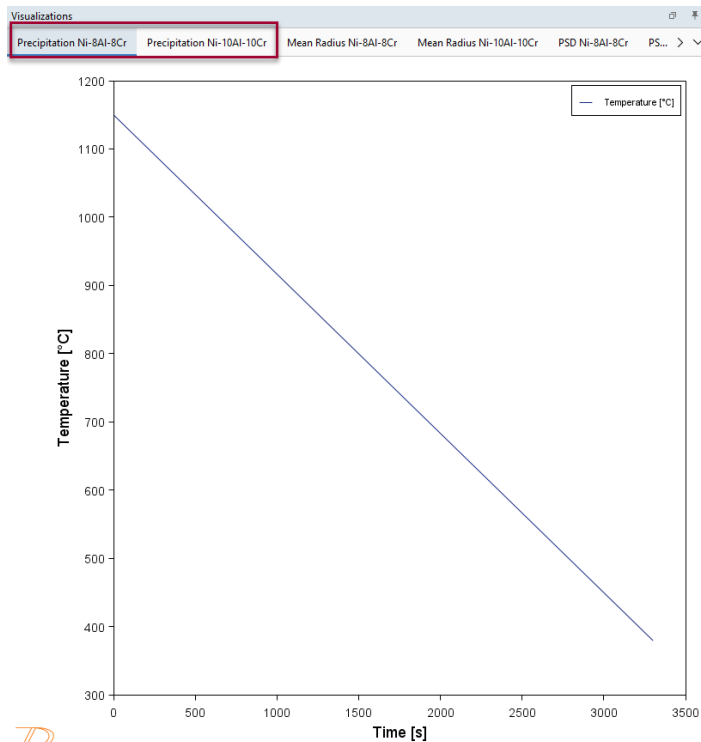

Figure 209: During set up of the calculation, you can preview the non-isothermal Thermal Profile(s). Click the tab in the Visualizations window to adjust settings on the Precipitation Calculator Configuration window. In this case the heat treatment is a continuous cooling curve, however any thermal profile can be modeled using the Non-isothermal Calculation Type.

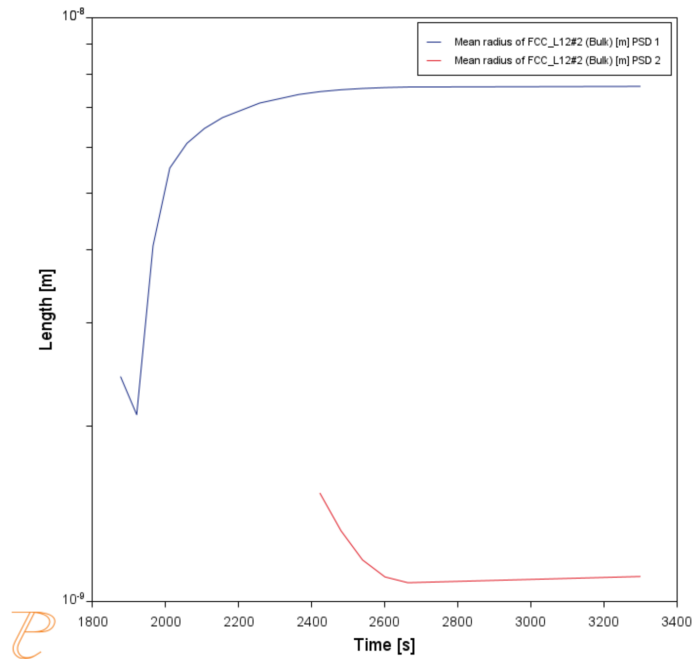

Figure 210: These results show the predicted evolution of the mean radius of gamma prime populations nucleating during the quench for the Ni-8Al-8Cr alloy. Note that the tertiary particles (second particle population) are very small, and this dispersion would appear monomodal without TEM characterization.

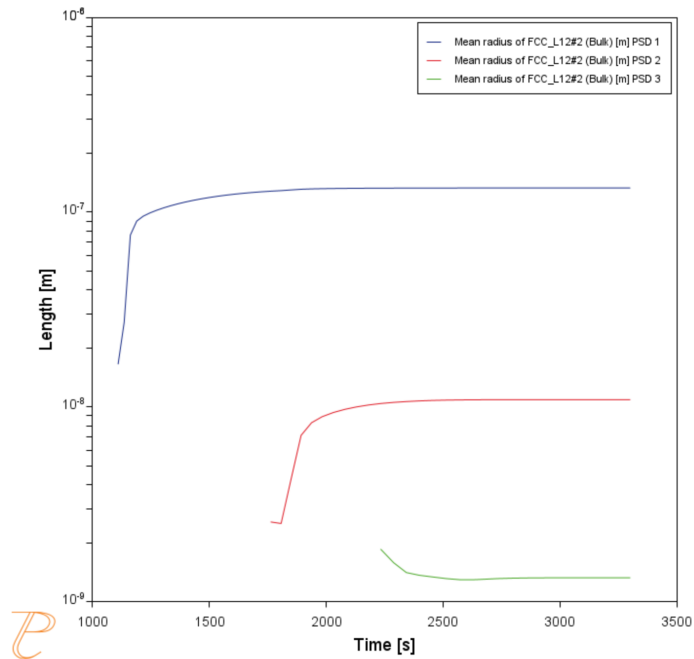

Figure 211: These results show the predicted evolution of the mean radius of gamma prime populations nucleating during the quench for the Ni-10Al-10Cr alloy. In this case three distinct particle populations are simulated to form, agreeing with [2013Roj].

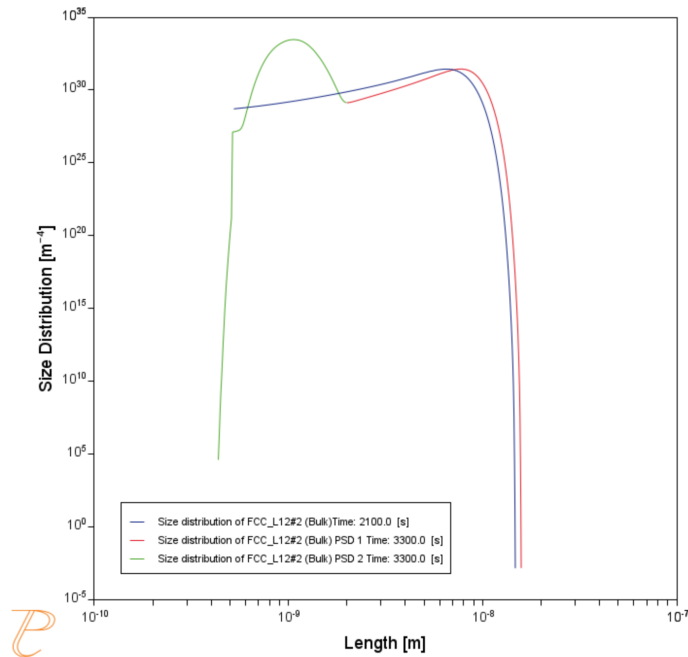

Figure 212: These results show the predicted size distributions of precipitates at different times during the quench of the for the Ni-8Al-8Cr alloy. The individual particle populations are distinguished using the “Separate multimodal PSD” option showing a bimodal distribution with very small nano-meter sized tertiary particles.

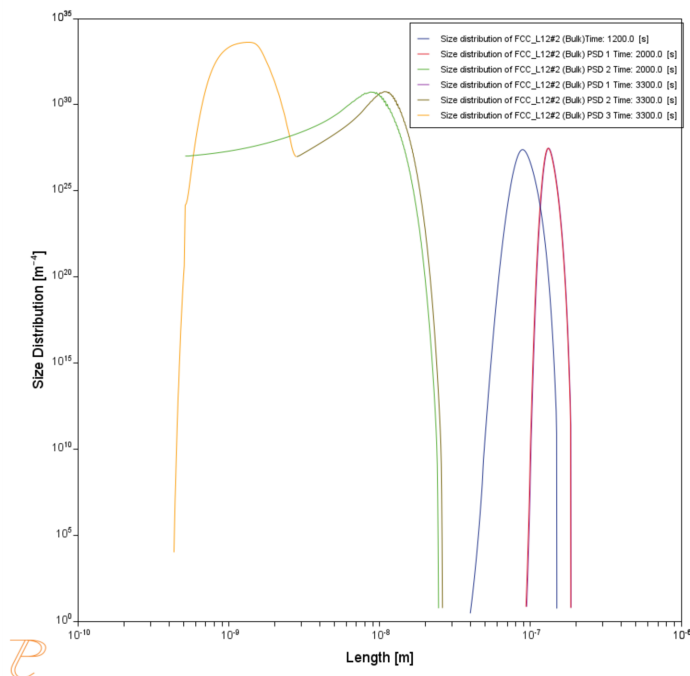

Figure 213: These results show the predicted size distributions of precipitates at different times during the quench for the Ni-10Al-10Cr alloy. The individual particle populations are distinguished using the “Separate multimodal PSD” option showing the formation of a tri-modal dispersion.

Reference

[2013Roj] T. Rojhirunsakool, S. Meher, J. Y. Hwang, S. Nag, J. Tiley, R. Banerjee, Influence of composition on monomodal versus multimodal γ' precipitation in Ni–Al–Cr alloys. *J. Mater. Sci.* 48, 825–831 (2013).

P_07: Continuous Cooling Transformation (CCT) Diagram of Ni-Al-Cr γ - γ'

This example shows you how to simulate a CCT (Continuous Cooling Transformation) diagram for gamma prime (γ') precipitation in a Ni-Cr-Al alloy using the Precipitation Calculator. A CCT calculation maintains the same cooling rate the entire time.

The system is a Ni-10Al-10Cr γ - γ' alloy and it is calculated and plotted with superimposition of the cooling rate values.

Project File and Step-By Step Instructions

- Folder: **Precipitation Module - TC-PRISMA**
- File name: P_07_Precipitation_Ni-Al-Cr_CCT_Gamma-Gamma_prime.tcu

Example Settings

System (System Definer)	
Database package	Demo: Nickel-based Super Alloys (NIDEMO and MNIDEMO)
Elements	Ni, Al, Cr
Conditions (Precipitation Calculator)	
Composition	Ni-10Al-10Cr Mole percent
Matrix phase	DIS_FCC_A1
Precipitate phase	FCC_L12#2
Precipitate Phase Data Parameters (Precipitation Calculator)	
Nucleation sites	Bulk
Interfacial energy	0.023 J/m ²
Calculation Type (Precipitation Calculator)	
Calculation type	CCT Diagram
Temperature Min to Max	500 to 1200 Kelvin

Cooling rate(s)	.01 .1 1 10 100 K/s
Stop criteria	Volume fraction of phase 1.0E-4

Visualizations



This example is included as a Precipitation Module (TC-PRISMA) tutorial on our [website](#) and as part of the playlist on our [YouTube channel](#).

Open the example project file to review the node setup on the **Project** window and the associated settings on the **Configuration** window for each node. For some types of projects, you can also adjust settings on the **Plot Renderer Configuration** window to preview results before performing the simulation. Click **Perform Tree** to generate plots and tables to see the results on the **Visualizations** window.



When you run (Perform) this example, it takes a few minutes for the calculations to complete.

There is a variety of information shown in the **Visualizations** window that can be viewed during configuration and after performing the calculation.

- **Thermal Profile:** When setting up a calculator on a **Configuration** window for **Isothermal** or **Non-isothermal Calculation Types**, you can preview the profile and adjust settings as needed. When you click a calculator node in the **Project** window, the matching name of the node is on the tab(s) displayed in the **Visualizations** window.



For **TTT Diagram** and **CCT Diagram** calculations there is nothing shown for the Precipitation Calculator tab in the **Visualizations** window as there is no Thermal Profile to be defined.

- **Plot or Table** results: After completing the set up and performing the calculation, to view the matching name of the node on tab(s) in the **Visualizations** window, either click a **Plot Renderer** or **Table Renderer** node in the **Project** window or click the tabs individually in the **Visualizations** window.

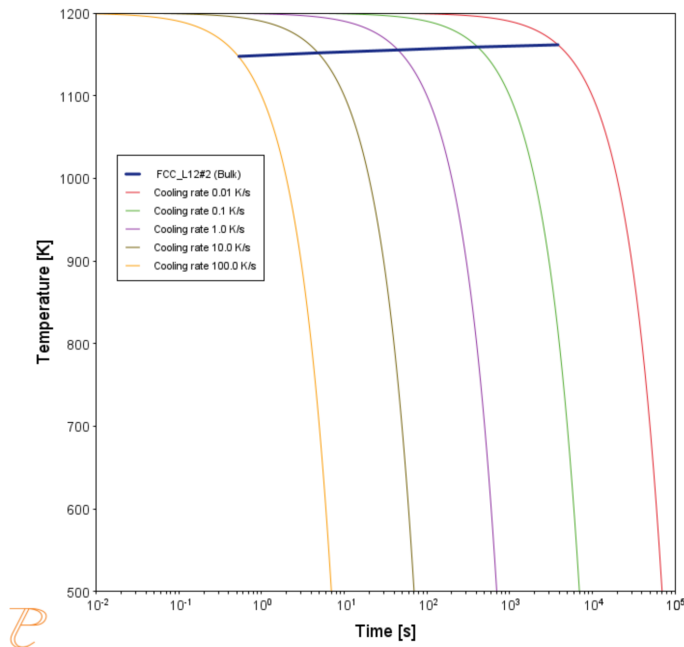

P

Figure 214: In this plot, the blue horizontal line shows the time it takes for γ' to transform at each of the cooling rates according to the stop criteria, which is set as $1e-4$ volume fraction. The cooling rates are represented by the multicoloured curved lines.

If you hover your mouse over the intersection of the blue line and any of the vertical lines, a yellow box shows the approximate time it takes for γ' to transform according to the stop criteria, which is a volume fraction of $1e-4$, followed by the approximate temperature.

Visualizations	
Plot Renderer 1	Table Renderer 1
Time [s]	FCC_L12#2 (Bulk) ^
0.53291	1147.52034
4.83553	1151.74191
44.76534	1155.24636
411.49295	1158.85356
3851.40185	1161.48826

Figure 215: An example of the table shown in the Visualizations window, which shows the same information as in the plot - for each cooling rate the temperature and the time it takes for γ' to transform according to the stop criteria, which is a volume fraction of $1e-4$.

P_08: Precipitation of Cu-Ti CU4Ti with Assumptions of Sphere and Needle Morphologies

In this isothermal calculation example, the precipitation of Cu₄Ti phase in a Cu-Ti binary alloy is calculated. To make a comparison, two separate simulations are performed, one assuming spherical morphology without elastic strain energy, and the other assuming needle morphology whose shape, determined by competition between interfacial energy and elastic strain energy, is changed during the simulation. The transformation strain is obtained from Borchers [1999Bor]. The results are compared with experiment results from Kampmann et al. [1987Kam].

Project File Information

- Folder: **Precipitation Module - TC-PRISMA**
- File name: P_08_Precipitation_Cu-Ti_CU4Ti1_Sphere_Needle.tcu

Example Settings



To ensure that the settings are done on the correct Precipitation Calculators, the **Sphere** and **Needle** nodes are renamed from **Precipitation Calculator** to match their morphology. The morphology is set in the **Precipitate Phase** section when you click **Show Details**.

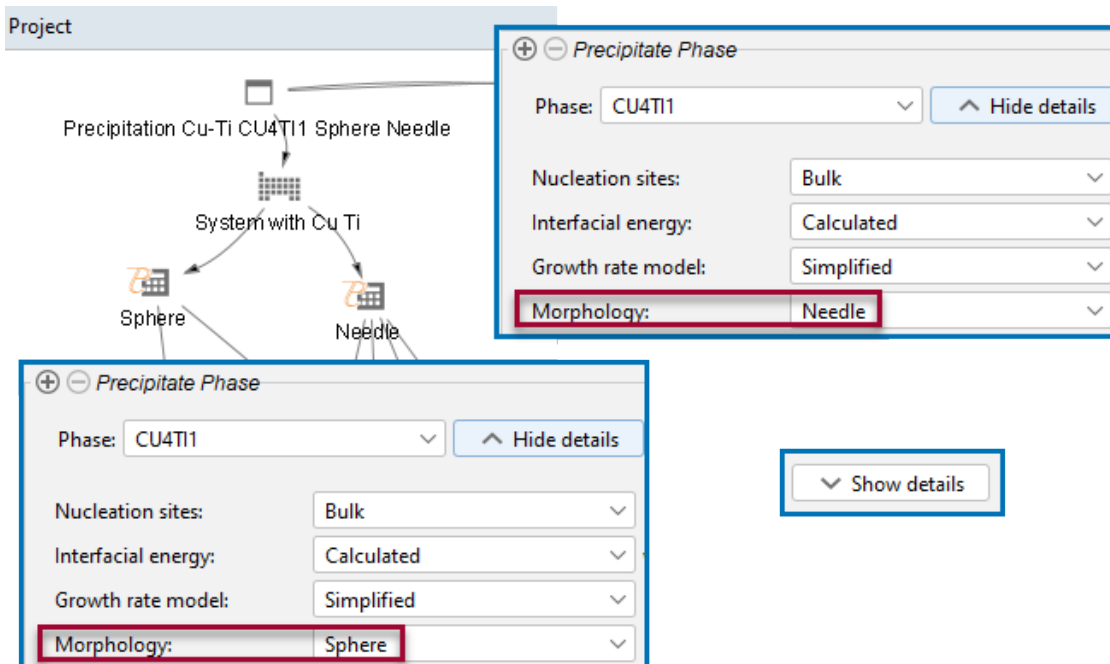

The screenshot displays the software interface for the precipitation module. On the left, a project tree shows the hierarchy: 'Project' -> 'Precipitation Cu-Ti CU4Ti1 Sphere Needle' -> 'System with Cu Ti' -> 'Sphere' and 'Needle'. Two 'Precipitate Phase' dialog boxes are shown. The top dialog box, associated with the 'Needle' node, has 'Morphology' set to 'Needle'. The bottom dialog box, associated with the 'Sphere' node, has 'Morphology' set to 'Sphere'. Both dialog boxes show other settings: Phase: CU4Ti1, Nucleation sites: Bulk, Interfacial energy: Calculated, and Growth rate model: Simplified. A 'Show details' button is also visible.

Dialog Box	Morphology
Top (Needle)	Needle
Bottom (Sphere)	Sphere

System (System Definer)	
Database package	Demo: Copper-based alloys (CUDEMO and MCUDEMO)
Elements	Cu, Ti
Sphere and Needle Conditions (Precipitation Calculator)	
Composition	Cu-1.9Ti Mole percent
Matrix phase	FCC_L12
Precipitate phase	CU4TI1
Matrix Phase Data Parameters (Precipitation Calculator)	
Mobility adjustment > Prefactor (click Show Details to display this setting)	Keep the default, Same for all elements, then enter 100 for the Prefactor.
Precipitate Phase Data Parameters (Precipitation Calculator)	
Nucleation sites	Bulk
Interfacial energy	The default
Morphology (click Show Details to display this setting)	For the Sphere node (renamed from Precipitation Calculator), keep the default. For the Needle node (renamed from Precipitation Calculator), Needle is selected.
Transformation strain (click Show Details to display this setting)	For the Sphere node (renamed from Precipitation Calculator), keep the default. For the Needle node (renamed from Precipitation Calculator), User defined is selected. In this example, the following settings are defined: <ul style="list-style-type: none">• ϵ_{11} and ϵ_{22} are set to 0.022• ϵ_{33} is set to 0.003
Calculation Type (Precipitation Calculator)	
Calculation type	Isothermal
Temperature	350° C

Simulation time	10,000 seconds
Datasets (Experimental File Reader)	
Borchers Mean radius vs Time and Borchers Number density vs Time	Data sets included with this example and imported to two Experimental File Readers. These data sets are used for the Mean Radius and Number Density plots, respectively.

Visualizations



Many of our Graphical Mode examples have video tutorials, which you can access in a variety of ways. When in Thermo-Calc, from the menu select **Help** → **Video Tutorials**, or from the main My Project window, click **Video Tutorials**. Alternately, you can go to the [website](#) or our [YouTube channel](#).

Open the example project file to review the node setup on the **Project** window and the associated settings on the **Configuration** window for each node. For some types of projects, you can also adjust settings on the **Plot Renderer Configuration** window to preview results before performing the simulation. Click **Perform Tree** to generate plots and tables to see the results on the **Visualizations** window.



When you run (Perform) this example, it takes a few minutes for the calculations to complete.

There is a variety of information shown in the **Visualizations** window that can be viewed during configuration and after performing the calculation.

- **Thermal Profile:** When setting up a calculator on a **Configuration** window for **Isothermal** or **Non-isothermal Calculation Types**, you can preview the profile and adjust settings as needed. When you click a calculator node in the **Project** window, the matching name of the node is on the tab(s) displayed in the **Visualizations** window.



For **TTT Diagram** and **CCT Diagram** calculations there is nothing shown for the Precipitation Calculator tab in the **Visualizations** window as there is no Thermal Profile to be defined.

- **Plot** or **Table** results: After completing the set up and performing the calculation, to view the matching name of the node on tab(s) in the **Visualizations** window, either click a **Plot Renderer** or **Table Renderer** node in the **Project** window or click the tabs individually in the **Visualizations** window.



In this example, all nodes are renamed in the **Project** window, and this matches each of the tab names in the **Visualizations** window.



For this **Isothermal** example, its **Thermal Profile** is also displayed in the **Visualizations** window showing the constant temperature entered for this calculation type. The tab names match the node names in the **Project** window.

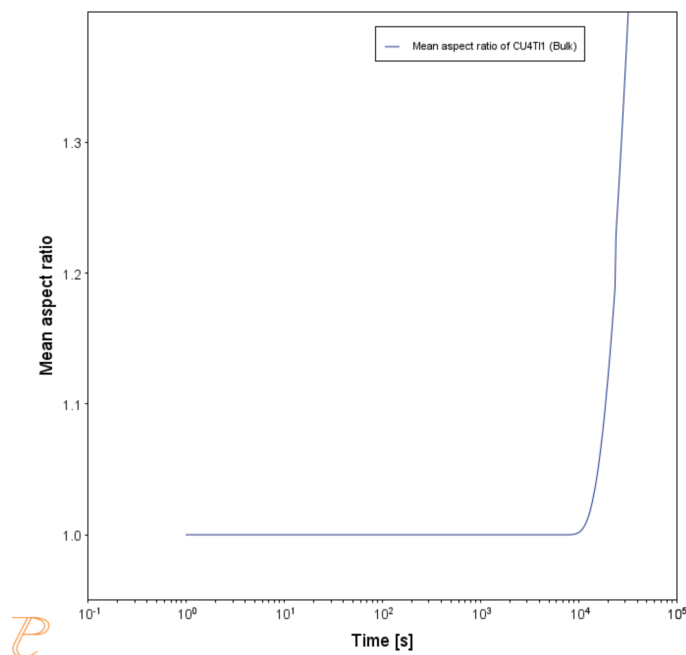

Figure 216: The predicted evolution of the morphology of needle shaped precipitates, showing how the mean aspect ratio changes during the isothermal heat treatment.

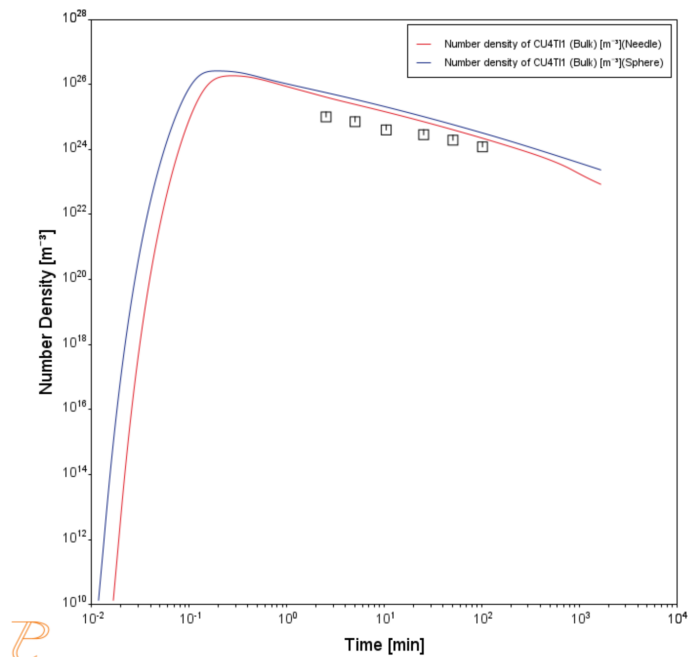

Figure 217: The results compare the predicted evolution of the mean size of precipitates with the experimental data from [1987Kam], comparing the spherical and needle shaped approximations of the precipitate morphology. Note how the needle shape approximation is closer to the experimental data.

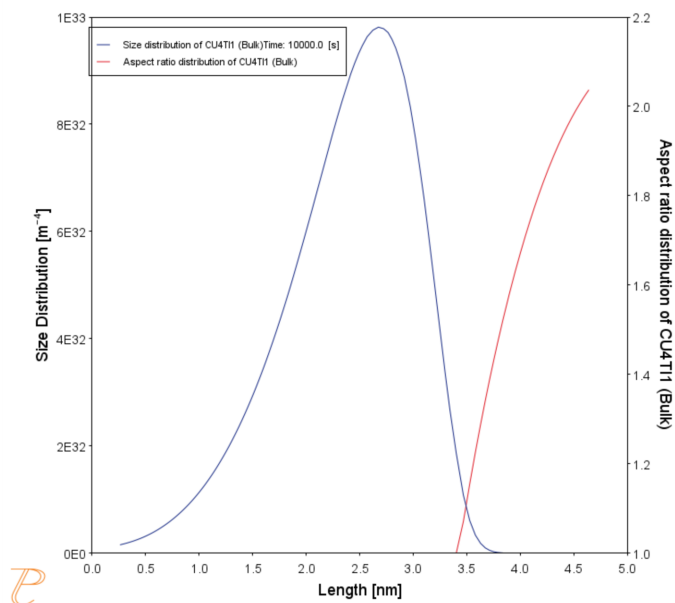

Figure 218: These results show both the predicted final particle size distribution from the needle shape simulation and the predicted relationship between the length of the precipitate and the needle aspect ratio.

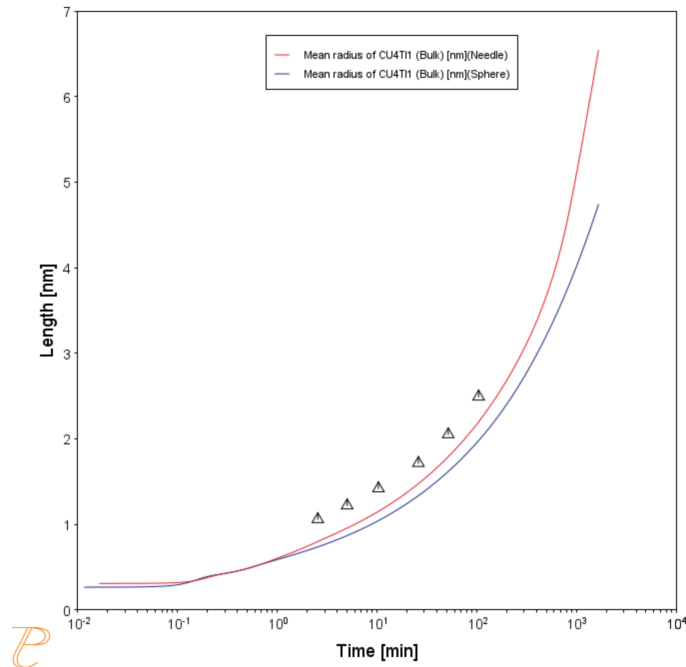

Figure 219: This shows the approximates the size of the needle shaped precipitates as a sphere of equivalent volume, and compares the experimental results of [1987Kam] with those obtained from a spherical and needle shaped approximation.

References

- [1987Kam] R. Kampmann, H. Eckerlebe, R. Wagner, 1987. "Precipitation Kinetics in Metastable Solid Solutions - Theoretical Considerations and Application to Cu-Ti Alloys." *Mat. Res. Soc. Symp. Proc.* 57: 525-542.
- [1999Bor] C. Borchers, Catastrophic nucleation during decomposition of Cu-0.9at.% Ti. *Philos. Mag. A.* 79, 537-547 (1999).

P_09: Precipitation of Al-Sc AL3SC with Assumption of Sphere and Cuboid Morphologies

In this isothermal calculation example, the precipitation of Al₃Sc phase from FCC_A1 matrix phase in an Al-Sc binary alloy is simulated. To make a comparison, two separate calculations are performed, one assuming spherical morphology without elastic strain energy, and the other assuming cuboid morphology whose shape is determined by competition between interfacial energy and elastic strain energy. The simulation results are compared with experimental data collected from Marquis and Seidman [2001Mar] and Novotny and Ardell [2001Nov]. In addition, mean cubic factor and cubic factor distribution are also plotted for cuboid shape to illustrate the spherical-cuboidal transition during precipitation.

Project File and Step-By Step Instructions

- Folder: **Precipitation Module - TC-PRISMA**
- File name: P_09_Precipitation_Al-Sc_AL3SC_Sphere_Cuboid.tcu

Example Settings



To ensure that the settings are done on the correct Precipitation Calculators, the **Sphere** and **Cuboid** nodes are renamed from **Precipitation Calculator** to match their morphology. The morphology is set in the **Precipitate Phase** section when you click **Show Details**. See P_08 for an example of this.

System (System Definer)

Database package | Demo: Aluminum-based alloys (ALDEMO, MALDEMO)

Elements | Al, Sc

Sphere and Cuboid Conditions (Precipitation Calculator)

Composition | Al-0.18Sc Mole percent

Matrix phase | FCC_A1

Precipitate phase	AL3SC
Matrix Phase Data Parameters (Precipitation Calculator)	
Elastic properties (click Show Details to display this setting)	<p>For the Sphere node (renamed from Precipitation Calculator), the default, Disregard is kept.</p> <p>For the Cuboid node (renamed from Precipitation Calculator), choose Cubic. Then enter the elastic constants accordingly. Default elastic constants are given based on the major element of the alloy system. In this example that is</p> <ul style="list-style-type: none">• c11 is 108.2 GPa• c12 is 61.3 GPa• c44 is 28.5 GPa
Precipitate Phase Data Parameters (Precipitation Calculator)	
Nucleation sites	Bulk
Interfacial energy	The default
Morphology (click Show Details to display this setting)	<p>For the Sphere node (renamed from Precipitation Calculator), keep the default.</p> <p>For the Cuboid node (renamed from Precipitation Calculator), Cuboid is selected.</p>
Transformation strain (click Show Details to display this setting)	<p>For the Sphere node (renamed from Precipitation Calculator), keep the default.</p> <p>For the Cuboid node (renamed from Precipitation Calculator), Calculate from molar volume is selected to obtain a purely dilatational strain.</p>
Calculation Type (Precipitation Calculator)	
Calculation type	Isothermal
Temperature	350° C
Simulation time	1.0E9 seconds
Datasets (Experimental File Reader)	
Dataset 1 and Dataset 2	Data sets included with this example and imported to one Experimental File Reader. It is used for the Mean Radius plot.

Visualizations



This example is included as a Precipitation Module (TC-PRISMA) tutorial on our [website](#) and as part of the playlist on our [YouTube channel](#).

Open the example project file to review the node setup on the **Project** window and the associated settings on the **Configuration** window for each node. For some types of projects, you can also adjust settings on the **Plot Renderer Configuration** window to preview results before performing the simulation. Click **Perform Tree** to generate plots and tables to see the results on the **Visualizations** window.

There is a variety of information shown in the **Visualizations** window that can be viewed during configuration and after performing the calculation.

- **Thermal Profile:** When setting up a calculator on a **Configuration** window for **Isothermal** or **Non-isothermal Calculation Types**, you can preview the profile and adjust settings as needed. When you click a calculator node in the **Project** window, the matching name of the node is on the tab(s) displayed in the **Visualizations** window.



For **TTT Diagram** and **CCT Diagram** calculations there is nothing shown for the Precipitation Calculator tab in the **Visualizations** window as there is no Thermal Profile to be defined.

- **Plot or Table** results: After completing the set up and performing the calculation, to view the matching name of the node on tab(s) in the **Visualizations** window, either click a **Plot Renderer** or **Table Renderer** node in the **Project** window or click the tabs individually in the **Visualizations** window.



In this example, all nodes are renamed in the **Project** window, and this matches each of the tab names in the **Visualizations** window.



For this **Isothermal** example, its **Thermal Profile** is also displayed in the **Visualizations** window showing the constant temperature entered for this calculation type. The tab names match the node names in the **Project** window.

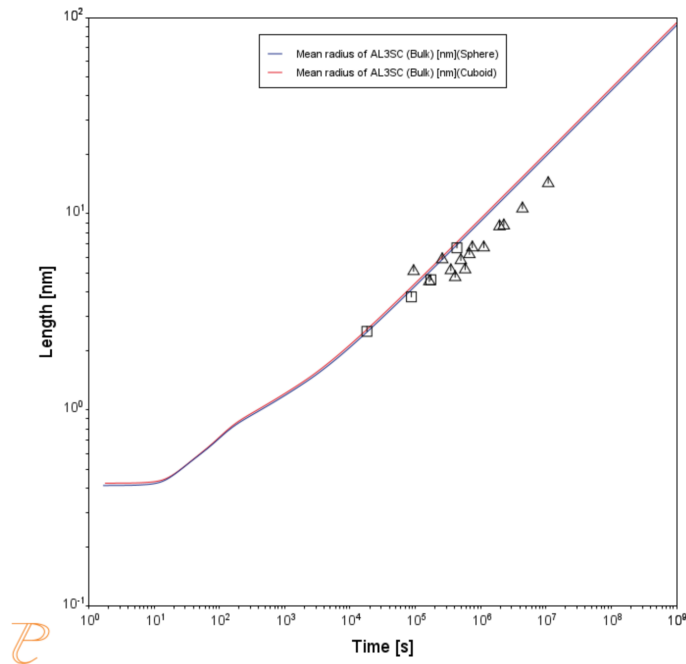
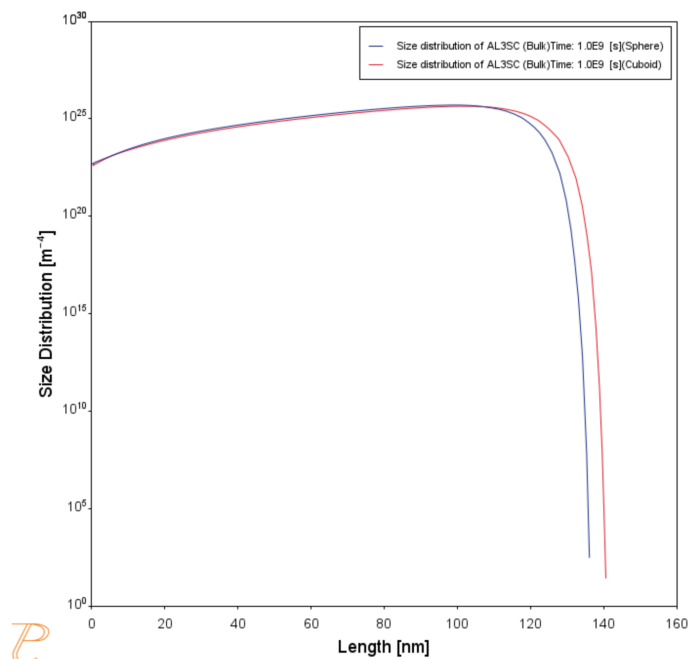
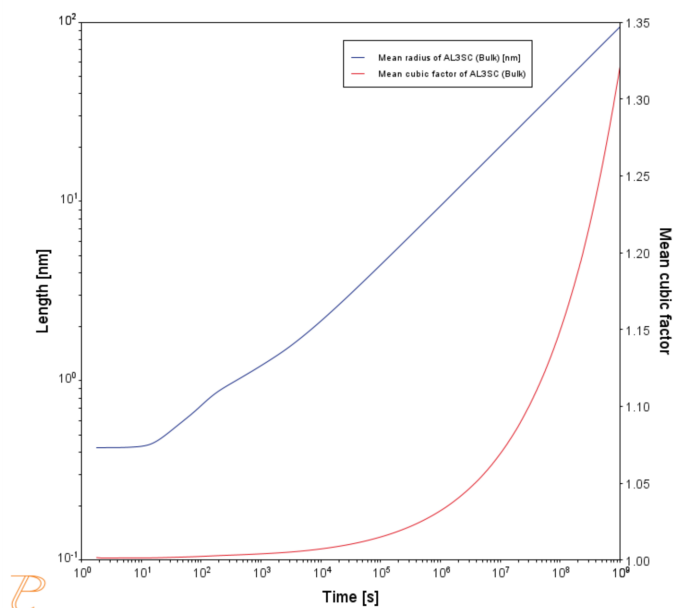

Figure 220: This shows the predicted evolution of the mean size of precipitates with the experimental data from [2001Mar, 2001Nov], comparing the spherical and cuboidal shaped approximations of the precipitate morphology. Although there is not significant difference in the results, capturing the correct geometry of the precipitate is important in subsequent calculations of precipitate spacing used in property calculations.



P

Figure 221: These results compare the predicted size distributions after heat treatment considering the spherical and cuboidal approximations of the precipitate morphology.



P

Figure 222: These results compare the predicted evolution of the mean particle radius and mean aspect ratio from using the cuboidal approximation of the precipitate morphology. In this case, the radius of a sphere of equivalent volume to the cuboidal precipitate is shown.

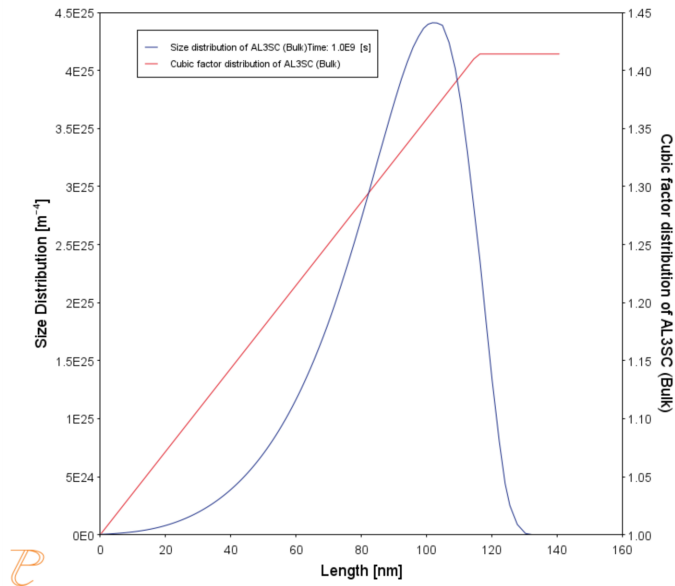

Figure 223: These results show the predicted size distribution of the precipitates obtained from the cuboidal approximation of the precipitate morphology. Also shown is the calculated size dependent cubic factor of the cuboids associated with this dispersion.

References

- [2001Mar] E. A. Marquis, D. N. Seidman, Nanoscale structural evolution of Al₃Sc precipitates in Al(Sc) alloys. *Acta Mater.* 49, 1909–1919 (2001).
- [2001Nov] G. M. Novotny, A. J. Ardell, Precipitation of Al₃Sc in binary Al–Sc alloys. *Mater. Sci. Eng. A Struct. Mater. Prop. Microstruct. Process.* 318, 144–154 (2001).

P_10: Initial Particle Size Distribution of Fe-Cr-C

This example demonstrates the effect of initial particle size distribution (PSD) of the precipitate phases on the overall precipitation kinetics. It uses two Precipitation Calculators to simulate and compare carbide precipitations from a ferritic BCC_A2 matrix in a Fe-0.1C-12Cr alloy. Three carbides, CEMENTITE, M23C7, and M7C3 are included in the calculations simulating a complex precipitation sequence with stable and meta-stable precipitate phases. The results show a large difference in predicted behaviour, with meta-stable precipitates dissolving earlier as a result of the stable precipitates existing in the initial condition.

This example also shows the different ways to create the initial size distribution.

- **Generate 3D PSD from distribution function:** CEMENTITE's PSD is approximated from an LSW distribution.
- **From File:** M23C6's PSD is loaded from a file.
- **Approximate the 3D PSD from experimental data:** M7C3's PSD is approximated from 1D experimental data descriptive of halved linear intercepts.

Project File Information

- Folder: **Precipitation Module - TC-PRISMA**
- File name: `P_10_Precipitation_Initial_PSD_FeCrC.tcu`

There are also two *.csv files available for you to use as a template for when you are importing data from a file.

- Input data for M23C6: `P_10_Precipitation_Initial_PSD_FeCrC_psd_3D_M23C6.csv`
- Input data for M7C3: `P_10_Precipitation_Initial_PSD_FeCrC_psd_1D_M7C3.csv`

Preexisting Particle Size Distribution

The **Preexisting Particle Size Distribution** window shown in [Figure 224](#) is a graphical representation of the radius versus corresponding number densities, with fields available to enter the initial precipitate composition and volume fraction. An editable table is also provided for the particle size distribution.

Cementite

The amount of Fe and Cr must be defined for Cementite for this alloy. Fe is set to the dependent component, and 72 mass percent of Cr is set. The option **Generate 3D PSD from distribution function** is chosen to create the PSD for Cementite. The initial volume fraction of 0.001 % is assumed. An LSW

distribution is selected with a mean radius of 1E-8m.

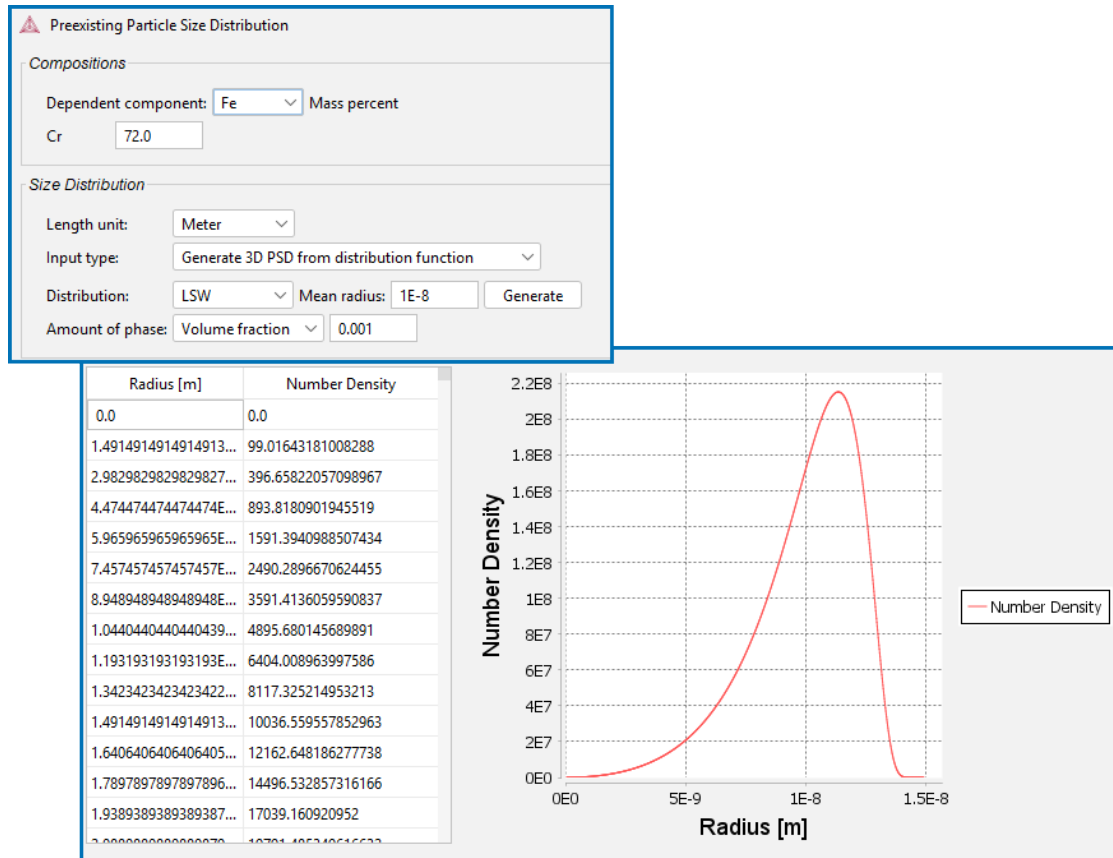

Figure 224: An LSW distribution with a mean radius of 1E-8m is used.

M23C6

The amount of Fe and Cr must be defined for M23C6 for this alloy. Fe is set to the dependent component, and 70 mass percent of Cr is set. The **From File** option is used to create the PSD.



The file loaded for M23C6 is available from the **Example files** → **Precipitation Module - TC-PRISMA** folder and is named `P_10_Precipitation_Initial_PSD_FeCrC_psd_3D_M23C6.csv`.

You can import data from a spreadsheet or text file (.xls, .xlsx, .csv, or .txt formats are acceptable). The initial volume fraction of 0.15 % is assumed.

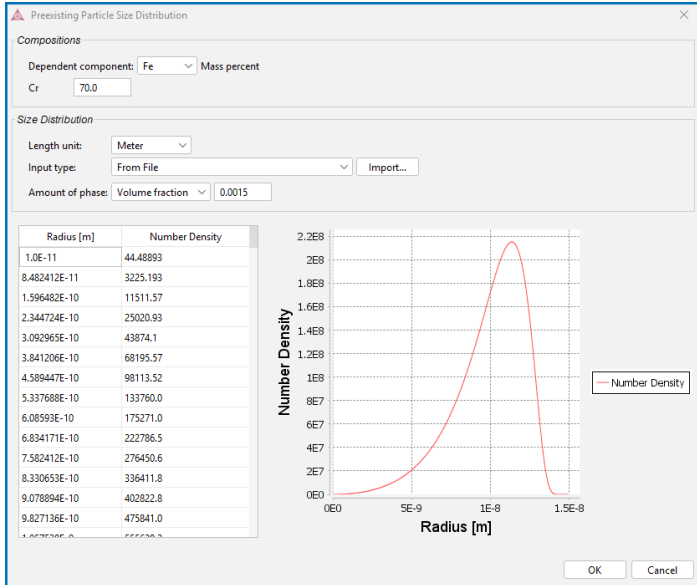

M7C3

The amount of Fe and Cr must be defined for M7C3 for this alloy. Fe is set to the dependent component, and 83 mass percent of Cr is set. The Approximate the 3D PSD from experimental data option is used to create the PSD.

In this example, the linear intercept method is used to measure the size distribution of M7C3 from micrographs descriptive of sectioning the dispersion. A size distribution of halved linear intercepts is created and is available as a file you can use as a template.



The file loaded for M7C3 is available from the **Example files** → **Precipitation Module - TC-PRISMA** folder and is named `P_10_Precipitation_Initial_PSD_FeCrC_psd_1D_M7C3.csv`.

The **Dimensionality of the exp. data** is set to 1D. The experimental data is loaded by importing the above named *.csv file. An **LSW Distribution** is used. When you click **Generate**, it calibrates the chosen distribution and stereology description to the experimental data. The initial volume fraction of 0.15 % is assumed.

Size Distribution

Length unit:

Input type:

Dimensionality of exp. data:

Distribution:

Amount of phase:

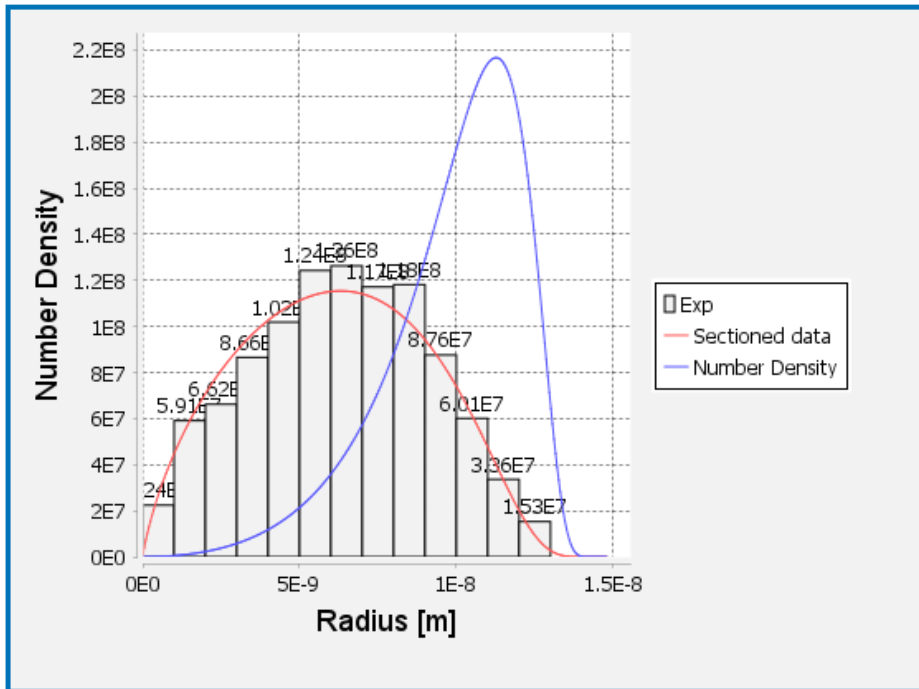

Example Settings

System (System Definer)	
Database package	Demo: Steels and Fe-alloys (FEDEMO and MFEDEMO)
Elements	Fe, C, Cr
Conditions (Precipitation Calculator)	
Composition	Fe-0.1C-12Cr Mass percent
Matrix phase	BCC_A2 All other defaults are kept.

Precipitate phases	CEMENTITE, M23C6 and M7C3
Precipitate Phase Data Parameters (Precipitation Calculator)	
Nucleation sites	Grain boundaries (all calculations): Calculated from the matrix settings with a wetting angle of 90°
Interfacial energy	User-defined function $f(r,T)$ (all calculations): <ul style="list-style-type: none">• CEMENTITE: 0.167 J/m²• M23C6 0.252 J/m²• M7C3 0.282 J/m²
Preexisting size distribution (click Show Details to display this setting)	<p>For the Precipitation Calculator including particle size distribution (PSD), and for all precipitate phases, this checkbox is selected.</p> <p>For each precipitate phase (CEMENTITE, M23C6 and M7C3), click Edit Particle Size Distribution to make changes to the parameters. A window opens with a graphical representation of the radius vs number density.</p> <p>Input type</p> <ul style="list-style-type: none">• Generate 3D PSD from distribution function - CEMENTITE uses this option in the example• From File - M23C6 uses this option in the example• Approximate the 3D PSD from experimental data - M7C3 uses this option in the example.
Calculation Type (Precipitation Calculator)	
Calculation type	Isothermal
Temperature	1053 K
Simulation time	400 000 seconds

Visualizations



Many of our Graphical Mode examples have video tutorials, which you can access in a variety of ways. When in Thermo-Calc, from the menu select **Help** → **Video Tutorials**, or from the main My Project window, click **Video Tutorials**. Alternately, you can go to the [website](#) or our [YouTube channel](#).

Open the example project file to review the node setup on the **Project** window and the associated settings on the **Configuration** window for each node. For some types of projects, you can also adjust settings on the **Plot Renderer Configuration** window to preview results before performing the simulation. Click **Perform Tree** to generate plots and tables to see the results on the **Visualizations** window.

There is a variety of information shown in the **Visualizations** window that can be viewed during configuration and after performing the calculation.

- **Thermal Profile:** When setting up a calculator on a **Configuration** window for **Isothermal** or **Non-isothermal Calculation Types**, you can preview the profile and adjust settings as needed. When you click a calculator node in the **Project** window, the matching name of the node is on the tab(s) displayed in the **Visualizations** window.



For **TTT Diagram** and **CCT Diagram** calculations there is nothing shown for the Precipitation Calculator tab in the **Visualizations** window as there is no Thermal Profile to be defined.

- **Plot or Table** results: After completing the set up and performing the calculation, to view the matching name of the node on tab(s) in the **Visualizations** window, either click a **Plot Renderer** or **Table Renderer** node in the **Project** window or click the tabs individually in the **Visualizations** window.



For this **Isothermal** example, its **Thermal Profile** is also displayed in the **Visualizations** window showing the constant temperature entered for this calculation type. The tab names match the node names in the **Project** window.

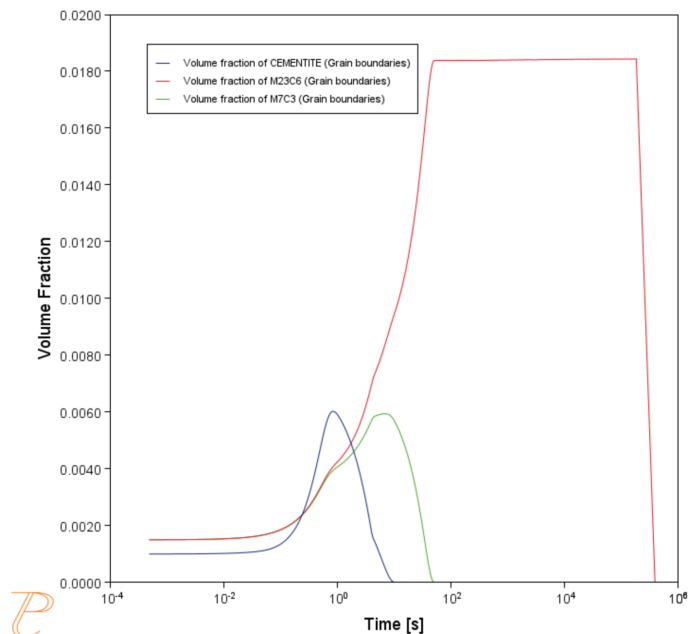

Figure 225: These results show the predicted volume fraction of cementite, M23C6, and M7C3 during an isothermal aging with an initial particle size distribution of each precipitate phase. The predicted kinetics are sensitive to the initial size, volume fraction, and composition of these precipitates.

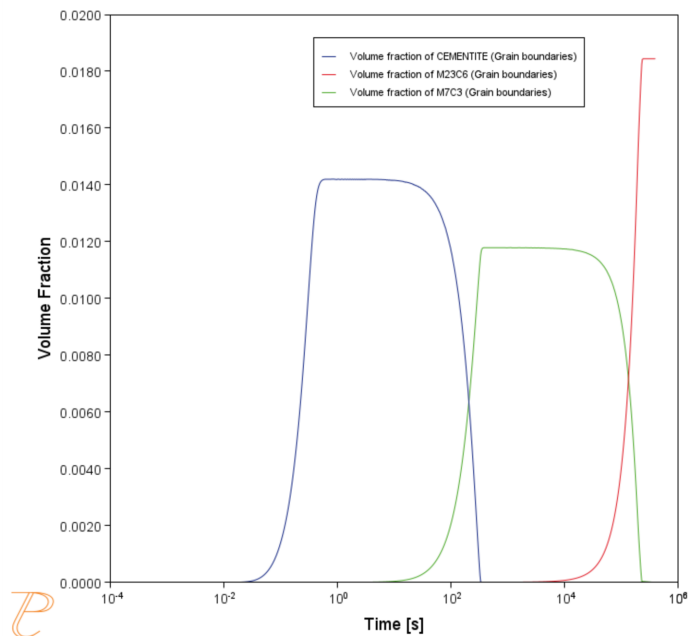

Figure 226: The predicted volume fraction of cementite, M23C6, and M7C3 during an isothermal aging with no precipitates in solution in the initial condition.

P_11: Interfacial Energy Function

In some cases, interfacial energy may be a function of temperature and/or particle radius. This example uses four Precipitation Calculators at four temperature points in 30 K increments: 673 K, 703 K, 733 K, and 763 K. It is an isothermal calculation to examine the mean radius of an Al-0.12Sc system. It uses an FCC_A1 matrix phase and AL3SC precipitate phase with bulk nucleation sites and user-defined interfacial energy function. The user defined interfacial energy function uses an error function to set a smooth transition of the interfacial energy from 0.065 J/m² to 0.085 J/m² for particle radii below and above 1e⁻⁸m and 5e⁻⁸m, respectively.

A dataset based on Iwamura and Miura [2004Iwa] data is compared with the calculated results.

Project File Information

- Folder: **Precipitation Module - TC-PRISMA**
- File name: P_11_Interfacial_energy_function.tcu

Example Settings

System (System Definer)	
Database package	Demo: Aluminum-based Alloys (ALDEMO, MALDEMO)
Elements	Al, Sc
Conditions (Precipitation Calculator)	
Composition	Al-0.12Sc Mole percent
Matrix phase	FCC_A1 All other defaults are kept.
Precipitate phase	AL3SC Nucleation sites (all calculations): Bulk (6.025E28 m ⁻³) Interfacial energy (all calculations): User-defined function f(r,T): 0.075+0.011*erf((r-3e-8)/1e-8 J/m ²)
Calculation Type (Precipitation Calculator)	
Calculation type	Isothermal (all calculations)

Temperature	Four temperature points in 30 K increments: 673 K, 703 K, 733 K, and 763 K.
Simulation time	1 000 000 seconds (all calculations)
Datasets (Experimental File Reader)	
Wamura 2004 (Dataset 1)	Data set included with this example and imported to one Experimental File Reader.

Visualizations



Many of our Graphical Mode examples have video tutorials, which you can access in a variety of ways. When in Thermo-Calc, from the menu select **Help** → **Video Tutorials**, or from the main My Project window, click **Video Tutorials**. Alternately, you can go to the [website](#) or our [YouTube channel](#).

Open the example project file to review the node setup on the **Project** window and the associated settings on the **Configuration** window for each node. For some types of projects, you can also adjust settings on the **Plot Renderer Configuration** window to preview results before performing the simulation. Click **Perform Tree** to generate plots and tables to see the results on the **Visualizations** window.



When you run (Perform) this example, it takes a few minutes for the calculations to complete.

There is a variety of information shown in the **Visualizations** window that can be viewed during configuration and after performing the calculation.

- **Thermal Profile:** When setting up a calculator on a **Configuration** window for **Isothermal** or **Non-isothermal Calculation Types**, you can preview the profile and adjust settings as needed. When you click a calculator node in the **Project** window, the matching name of the node is on the tab(s) displayed in the **Visualizations** window.



For **TTT Diagram** and **CCT Diagram** calculations there is nothing shown for the Precipitation Calculator tab in the **Visualizations** window as there is no Thermal Profile to be defined.

- **Plot or Table** results: After completing the set up and performing the calculation, to view the matching name of the node on tab(s) in the **Visualizations** window, either click a **Plot Renderer** or **Table Renderer** node in the **Project** window or click the tabs individually in the **Visualizations** window.



For this **Isothermal** example, its **Thermal Profile** is also displayed in the **Visualizations** window showing the constant temperature entered for this calculation type. The tab names match the node names in the **Project** window.

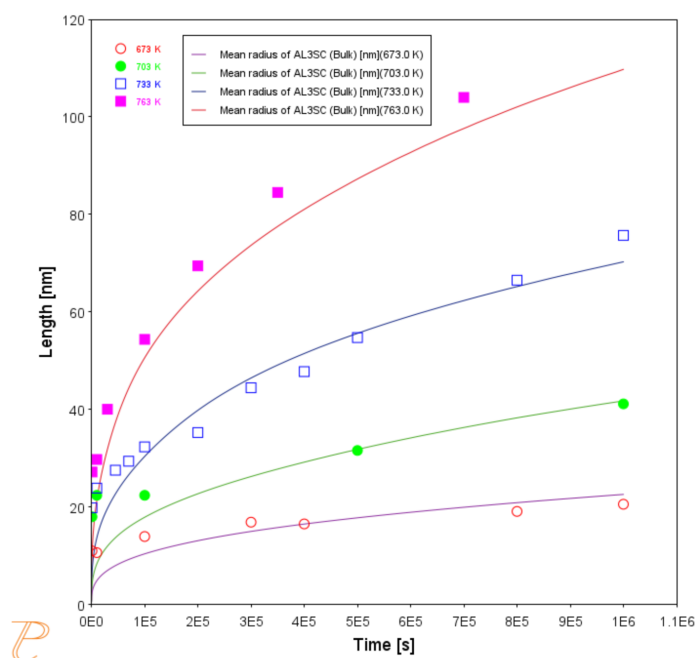

Figure 227: The results of an isothermal calculation to examine the mean radius of an Al-0.12Sc system with experimental data from [2004Iwa].

Reference

[2004Iwa] S. Iwamura, Y. Miura, Loss in coherency and coarsening behavior of Al₃Sc precipitates. Acta Mater. 52, 591–600 (2004).

P_12: Comparing Growth Rate Models for an Al-Zr System

This example compares the **Simplified**, **General**, and **Advanced** growth rate models for an Al-Zr system. The resulting plot compares the mean radius of the spheres for each AL3ZR_D023 precipitate phase calculated for each type of growth rate model.

All models treat a spherical particle (precipitate) of stoichiometric composition or with negligible atomic diffusivity. Local equilibrium at the precipitate-matrix interface is assumed.

When you use the *Advanced* model, the velocity of a moving phase interface and the operating tie-line are solved together from flux-balance equations. This model can treat both high supersaturation and cross diffusion rigorously. It can also capture the transition between NPLE (non-partitioning local equilibrium) and PLE (partitioning local equilibrium) without any *ad hoc* treatment.

The *Simplified* model is based on the quasi-steady state diffusion approximation, and estimates solute partitioning with matrix composition and nuclei composition instead of time-consuming stepwise tie-line calculations. It also neglects cross diffusion for simplicity.

The *General* model can be considered the same theoretical approximation as, but an improvement over, the *Simplified* model, with cross-diffusion terms taken into account, as well as adjustment of Gibbs-Thomson effect and effective diffusivity implemented. A dataset based on Knipling et al. [2008Kni] data is compared with the calculated results.

Project File Information

- Folder: **Precipitation Module - TC-PRISMA**
- File name: P_12_Precipitation_Al-Zr_GrowthRateModel_comparison.tcu

Example Settings

System (System Definer)	
Database package	Demo: Aluminum-based Alloys (ALDEMO, MALDEMO)
Elements	Al, Zr
Conditions (Precipitation Calculator)	
Composition	Al-0.2Zr Mole percent
Matrix phase	FCC_A1

	All other defaults are kept.
Precipitate phase	AL3ZR_D023 Click Show Details to select the Growth rate model (Simplified, Advanced and General) . All other defaults are kept.
Calculation Type (Precipitation Calculator)	
Calculation type	Isothermal
Temperature	425 Celsius
Simulation time	400 hours
Datasets (Experimental File Reader)	
2008 Knipling	Data set included with this example and imported to one Experimental File Reader.

Visualizations



Many of our Graphical Mode examples have video tutorials, which you can access in a variety of ways. When in Thermo-Calc, from the menu select **Help** → **Video Tutorials**, or from the main My Project window, click **Video Tutorials**. Alternately, you can go to the [website](#) or our [YouTube channel](#).

Open the example project file to review the node setup on the **Project** window and the associated settings on the **Configuration** window for each node. For some types of projects, you can also adjust settings on the **Plot Renderer Configuration** window to preview results before performing the simulation. Click **Perform Tree** to generate plots and tables to see the results on the **Visualizations** window.



When you run (Perform) this example, it takes a few minutes for the calculations to complete.

There is a variety of information shown in the **Visualizations** window that can be viewed during configuration and after performing the calculation.

- **Thermal Profile:** When setting up a calculator on a **Configuration** window for **Isothermal** or **Non-isothermal Calculation Types**, you can preview the profile and adjust settings as needed. When you click a calculator node in the **Project** window, the matching name of the node is on the tab(s) displayed in the **Visualizations** window.



For **TTT Diagram** and **CCT Diagram** calculations there is nothing shown for the Precipitation Calculator tab in the **Visualizations** window as there is no Thermal Profile to be defined.

- **Plot or Table** results: After completing the set up and performing the calculation, to view the matching name of the node on tab(s) in the **Visualizations** window, either click a **Plot Renderer** or **Table Renderer** node in the **Project** window or click the tabs individually in the **Visualizations** window.



For this **Isothermal** example, its **Thermal Profile** is also displayed in the **Visualizations** window showing the constant temperature entered for this calculation type. The tab names match the node names in the **Project** window.

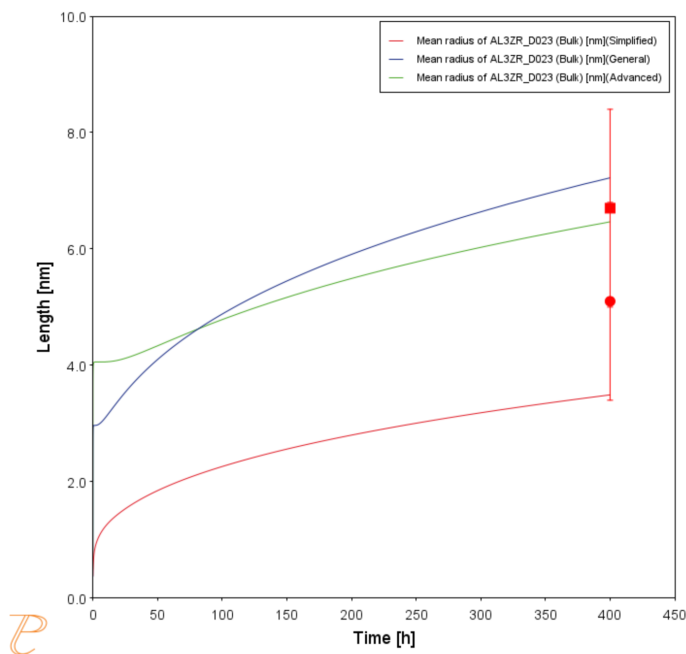

Figure 228: This shows the impact of the available growth rate settings options and compares the mean radius measurements of [2008Kni] with results obtained from the simplified, general, and advanced growth rate models. The experimental data includes measurements taken from different dendrites.

Reference

[2008Kni] K. E. Knipling, D. C. Dunand, D. N. Seidman, Precipitation evolution in Al–Zr and Al–Zr–Ti alloys during isothermal aging at 375–425 °C. *Acta Mater.* 56, 114–127 (2008).

P_13: Paraequilibrium Precipitation of Cementite Fe-C-Cr

In this example, the precipitation of cementite during tempering of a Fe-Cr-C steel is simulated considering two interface conditions: one is the usual ortho-equilibrium condition; the other is the para-equilibrium condition. The simulation results are compared with the experimental data from Sakuma et al. [1980Sak].

This example demonstrates that the early stage of the cementite precipitation can only be accounted for by a simulation applying the para-equilibrium condition, under which the precipitation kinetics are controlled by the diffusion of C. The comparison also shows a later stage gradual transition from the para-equilibrium condition to the ortho-equilibrium condition, and if the tempering time is long enough the diffusion of Cr has a dominating effect on the coarsening of cementite.

Project File Information

- Folder: **Precipitation Module - TC-PRISMA**
- File name: `P_13_Precipitation_Fe-C-Cr_Paraequilibrium_Precipitation_of_Cementite.tcu`

Example Settings

System (System Definer)	
Database package	Demo: Steels and Fe-alloys (FEDEMO, MFEDEMO)
Elements	Fe, Cr, C
Conditions (Precipitation Calculator)	
Composition	Fe-0.95Cr-1.065C Mass percent
Matrix phase	BCC_A2 All other defaults are kept.
Precipitate phase	CEMENTITE_D011 Click Show Details to select the Growth rate model (Simplified (OE) and Para-eq) (PE) . All other defaults are kept.
Calculation Type (Precipitation Calculator)	
Calculation type	Isothermal
Temperature	773 Kelvin

Simulation time	20 hours for the paraequilibrium model and 600 hours for the simplified model.
-----------------	--------------------------------------------------------------------------------

Datasets (Experimental File Reader)

1980 Sakuma	Data set included with this example and imported to one Experimental File Reader.
-------------	-----------------------------------------------------------------------------------

Visualizations



Many of our Graphical Mode examples have video tutorials, which you can access in a variety of ways. When in Thermo-Calc, from the menu select **Help** → **Video Tutorials**, or from the main My Project window, click **Video Tutorials**. Alternately, you can go to the [website](#) or our [YouTube channel](#).

Open the example project file to review the node setup on the **Project** window and the associated settings on the **Configuration** window for each node. For some types of projects, you can also adjust settings on the **Plot Renderer Configuration** window to preview results before performing the simulation. Click **Perform Tree** to generate plots and tables to see the results on the **Visualizations** window.



When you run (Perform) this example, it can take over two hours to complete the calculations.

There is a variety of information shown in the **Visualizations** window that can be viewed during configuration and after performing the calculation.

- **Thermal Profile:** When setting up a calculator on a **Configuration** window for **Isothermal** or **Non-isothermal Calculation Types**, you can preview the profile and adjust settings as needed. When you click a calculator node in the **Project** window, the matching name of the node is on the tab(s) displayed in the **Visualizations** window.



For **TTT Diagram** and **CCT Diagram** calculations there is nothing shown for the Precipitation Calculator tab in the **Visualizations** window as there is no Thermal Profile to be defined.

- **Plot or Table** results: After completing the set up and performing the calculation, to view the matching name of the node on tab(s) in the **Visualizations** window, either click a **Plot Renderer** or **Table Renderer** node in the **Project** window or click the tabs individually in the **Visualizations** window.



For this **Isothermal** example, its **Thermal Profile** is also displayed in the **Visualizations** window showing the constant temperature entered for this calculation type. The tab names match the node names in the **Project** window.

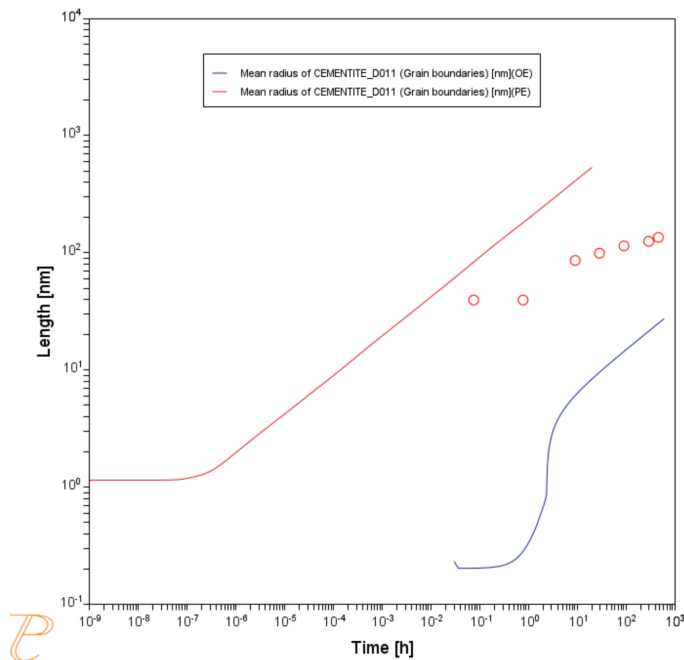

Figure 229: These results compare the predicted and measured evolution of the mean radius of cementite with the experimental data from [1980Sak] to simulation predictions obtained from the ortho-equilibrium (OE), and para-equilibrium (PE) approximations of the precipitate composition. The precipitate growth kinetics exhibited by cementite can be rationalized by the transition from PE to OE.

Reference

[1980Sak] T. Sakuma, N. Watanabe, T. Nishizawa, The Effect of Alloying Element on the Coarsening Behavior of Cementite Particles in Ferrite. *Trans. Japan Inst. Met.* 21, 159–168 (1980).

P_14: Grain Growth and the Zener Pinning Effect

This example demonstrates the simulation of normal grain growth and the pinning effect [1948Smi; 1998Man] of precipitated second-phase particles on the grain boundary motion.

To investigate the grain growth and Zener pinning effect, an Fe-0.2C (wt.%) binary alloy, with a BCC_A2 matrix phase and CEMENTITE precipitate phase, is simulated and uses the demonstration steel databases, FEDEMO and MFEDEMO. These databases are available to all users (i.e. you do not need a license for the Precipitation Module (TC-PRISMA)) and contain the necessary thermodynamic and kinetic data needed for the calculation.

Project File Information

- Folder: **Precipitation Module - TC-PRISMA**
- File name: P_14_Precipitation_Fe-C-Ferrite-Grain_Growth_with_Zener_Pinning.tcu

Example Settings

System (System Definer)	
Database package	Demo: Steels and Fe-alloys (FEDEMO and MFEDEMO)
Elements	Fe, C
Conditions (Precipitation Calculator)	
Composition	Fe-0.2C Mass percent
Matrix phase	<p>BCC_A2</p> <ul style="list-style-type: none">• Grain boundary energy (J/m²): 0.5• Grain boundary mobility: Prefactor(m⁴/Js): 2×10^{-15}• Click to Edit grain size distribution. Then Initial grain size distribution: Hillert distribution with average radius of 3.2×10^{-6} m• Mobility adjustment: Same for all elements. Prefactor 0.08.

Precipitate phase	CEMENTITE <ul style="list-style-type: none">Zener pinning parameters: Cutoff size (m): 8.0×10^{-7}
Calculation Type (Precipitation Calculator)	
Calculation type	Isothermal
Temperature	722 °C
Simulation time	35 hours
Datasets (Experimental File Reader)	
[1975Hel]	Data sets included with this example and imported to two Experimental File Readers.

Visualizations



This example is included as a Precipitation Module (TC-PRISMA) tutorial on our [website](#) and as part of the playlist on our [YouTube channel](#).

Open the example project file to review the node setup on the **Project** window and the associated settings on the **Configuration** window for each node. For some types of projects, you can also adjust settings on the **Plot Renderer Configuration** window to preview results before performing the simulation. Click **Perform Tree** to generate plots and tables to see the results on the **Visualizations** window.

There is a variety of information shown in the **Visualizations** window that can be viewed during configuration and after performing the calculation.

- Thermal Profile:** When setting up a calculator on a **Configuration** window for **Isothermal** or **Non-isothermal Calculation Types**, you can preview the profile and adjust settings as needed. When you click a calculator node in the **Project** window, the matching name of the node is on the tab(s) displayed in the **Visualizations** window.



For **TTT Diagram** and **CCT Diagram** calculations there is nothing shown for the Precipitation Calculator tab in the **Visualizations** window as there is no Thermal Profile to be defined.

- **Plot** or **Table** results: After completing the set up and performing the calculation, to view the matching name of the node on tab(s) in the **Visualizations** window, either click a **Plot Renderer** or **Table Renderer** node in the **Project** window or click the tabs individually in the **Visualizations** window.



For this **Isothermal** example, its **Thermal Profile** is also displayed in the **Visualizations** window showing the constant temperature entered for this calculation type. The tab names match the node names in the **Project** window.

The calculated equilibrium volume fraction of CEMENTITE at 722 °C (0.02786), using FEDEMO, matches that (0.02787) of a Fe-0.2C-0.004S-0.0004O-0.001N-0.001Al (wt.%) multicomponent commercial alloy, calculated using the latest version of the TCS Steel and Fe-alloys Database (TCFE), an alloy that was studied by Hellman and Hillert [1975Hel]. The mobility adjustment assures the precipitation kinetics of CEMENTITE phase in Fe-C system matches that of experimental data [1975Hel] of the commercial counterpart (and shown in Figure 230)

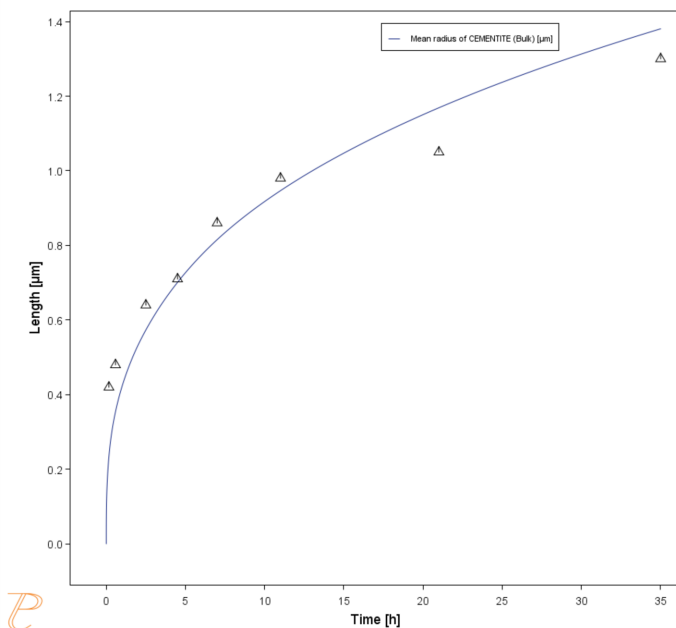

Figure 230: The evolution of the mean radius of cementite comparing the experimental data from [1975Hel] with the Precipitation Calculator results.

The grain boundary energy was chosen to be a reasonable value of 0.5 J/m^2 . There is a large discrepancy, in several orders of magnitude, among experimental data regarding the grain boundary mobility. In the present calculation, a value of $2 \times 10^{-15} \text{ m}^4/\text{Js}$ was chosen.

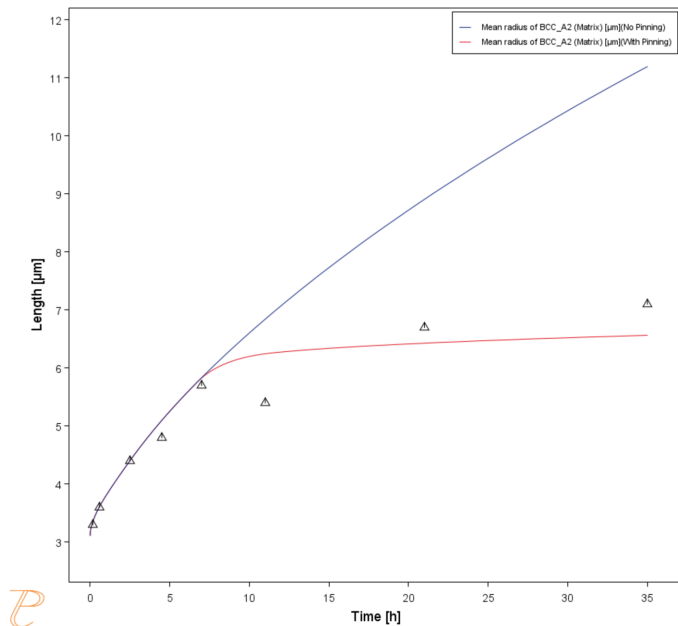

Figure 231: The evolution of the mean grain radius of ferrite comparing the experimental data from [1975Hel] with predictions made with and without Zener pinning from an evolving dispersion of cementite precipitates.

References

- [1948Smi] C. S. Smith, Grains, Phases, and Interfaces - an Interpretation of Microstructure. Trans. AIME. 175, 15–51 (1948).
- [1975Hel] P. Hellman, M. Hillert, On the Effect of Second-Phase Particles on Grain Growth. Scand. J. Metall. 4, 211–219 (1975).
- [1998Man] P. A. Manohar, M. Ferry, T. Chandra, Five Decades of the Zener Equation. ISIJ Int. 38, 913–924 (1998).

P_15: Smooth Transition from Paraequilibrium to Ortho-equilibrium

In this example, the precipitation of cementite during tempering of an Fe-Mn-C steel is simulated considering three interface conditions: the usual ortho-equilibrium (OE) condition; paraequilibrium (PE) condition; and a smooth transition from paraequilibrium to ortho-equilibrium condition (PE-OE). The simulation results are compared with the experimental data from Miyamoto et al. [2007Miy].



The Precipitation Calculator nodes are renamed in the example to match the abbreviations for the three interface conditions considered: OE, PE, and PE-OE. Also see the video to learn how to create this example.

This example demonstrates that the early stage of the cementite precipitation follows a PE condition, under which the precipitation kinetics is controlled by the diffusion of C. At a later stage, gradual transition from PE condition to OE condition occurs, and if the tempering time is long enough the diffusion of Mn has a dominating effect on the coarsening of cementite. While a *Simplified* model follows the OE condition and a *Para-eq* model follows PE condition, the *PE Automatic* model enables the smooth transition from PE condition at early stage to OE condition at a late stage.

The example uses the demonstration steel databases, FEDEMO and MFEDEMO. These databases are available to all users (i.e. you do not need a license for the Precipitation Module (TC-PRISMA)) and contain the necessary thermodynamic and kinetic data needed for the calculation.

Project File Information

- Folder: **Precipitation Module - TC-PRISMA**
- File name: `P_15_Precipitation_Fe-C-Mn_PE-OE_Precipitation_of_Cementite.tcu`

Example Settings

System (System Definer)

Database
package

Demo: Steels and Fe-alloys (FEDEMO and MFEDEMO)

Elements	Fe, Mn, C
Conditions (Precipitation Calculator)	
Composition	Fe-1.96Mn-0.61C mass percent
Matrix phase	<p>BCC_A2</p> <p>Click Show Details:</p> <ul style="list-style-type: none">• Grain size: Average radius 1.0E-7m• Grain aspect ratio: 100.0• Mobility adjustment: Keep the default, Same for all elements, then enter 0.008 for the Prefactor, and -7e4 J/mol for the Activation energy. <p>All other defaults are kept.</p>
Precipitate phase	<p>CEMENTITE_D011</p> <p>Click Show Details to select the Growth rate model (Simplified, Para-eq, and PE Automatic). All other defaults are kept.</p>
Calculation Type (Precipitation Calculator)	
Calculation type	Isothermal
Temperature	923.15 Kelvin
Simulation time	1E6 seconds for Simplified and PE Automatic models, and 5 seconds for Para-eq model
Datasets (Experimental File Reader)	
Mean Radius Exp	Data set including experimental mean radius of cementite
Mn Concentration	Data set including experimental Mn composition in cementite

Visualizations



This example is included as a Precipitation Module (TC-PRISMA) tutorial on our [website](#) and as part of the playlist on our [YouTube channel](#).

Open the example project file to review the node setup on the **Project** window and the associated settings on the **Configuration** window for each node. For some types of projects, you can also adjust settings on the **Plot Renderer Configuration** window to preview results before performing the simulation. Click **Perform Tree** to generate plots and tables to see the results on the **Visualizations** window.



When you run (Perform) this example, it takes a few minutes for the calculations to complete.

There is a variety of information shown in the **Visualizations** window that can be viewed during configuration and after performing the calculation.

- **Thermal Profile:** When setting up a calculator on a **Configuration** window for **Isothermal** or **Non-isothermal Calculation Types**, you can preview the profile and adjust settings as needed. When you click a calculator node in the **Project** window, the matching name of the node is on the tab(s) displayed in the **Visualizations** window.



For **TTT Diagram** and **CCT Diagram** calculations there is nothing shown for the Precipitation Calculator tab in the **Visualizations** window as there is no Thermal Profile to be defined.

- **Plot or Table** results: After completing the set up and performing the calculation, to view the matching name of the node on tab(s) in the **Visualizations** window, either click a **Plot Renderer** or **Table Renderer** node in the **Project** window or click the tabs individually in the **Visualizations** window.



For this **Isothermal** example, its **Thermal Profile** is also displayed in the **Visualizations** window showing the constant temperature entered for this calculation type. The tab names match the node names in the **Project** window.

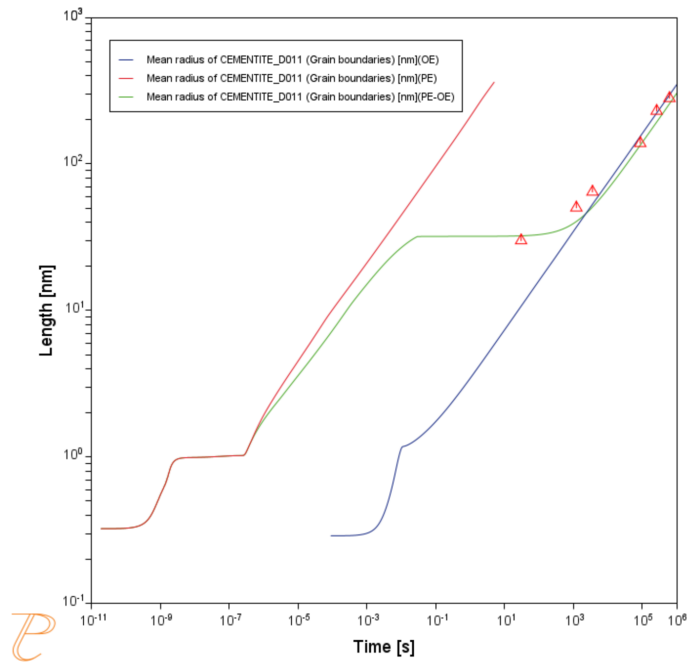

Figure 232: A comparison between the measurements of mean cementite radius from [2007Miy] with the simplified (OE), para-eq (PE), and PE Automatic (PE-OE) growth models. The PE-OE model is needed to capture the nucleation, growth, and coarsening behavior of cementite.

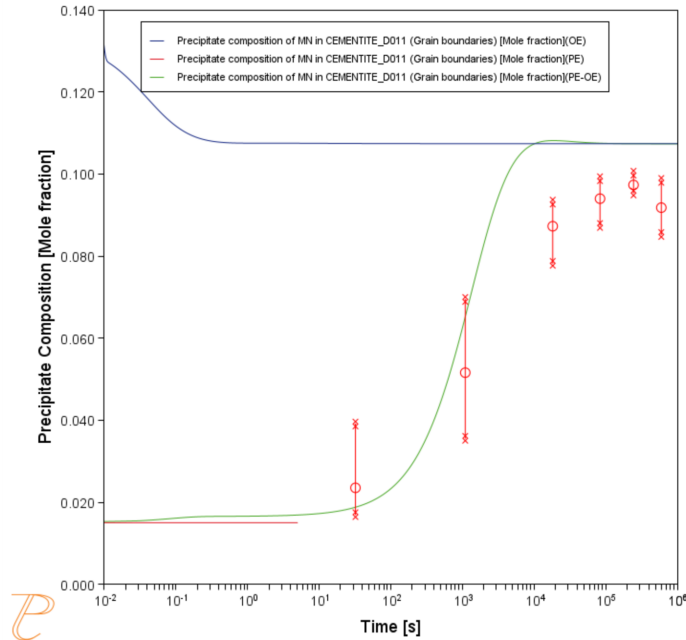

Figure 233: A comparison of the evolution of the cementite Mn composition during isothermal aging at 923.15 K between the experimental data from [2007Miy] with model predictions obtained from the simplified (OE) growth model, the para-eq (PE) growth model, and the PE Automatic (PE-OE) growth model. The PE-OE model captures the behavior shown in the experimental data, where the Mn composition transitions from the initial ferrite composition towards the equilibrium cementite composition.

Reference

[2007Miy] G. Miyamoto, J. Oh, K. Hono, T. Furuhashi, T. Maki, Effect of partitioning of Mn and Si on the growth kinetics of cementite in tempered Fe–0.6 mass% C martensite. *Acta Mater.* 55, 5027–5038 (2007).

P_16 Isothermal Coarsening and a 3D to 2D Stereological Conversion

This example demonstrates the use of the **3D → 2D** stereological conversion functionality to compare Precipitation Module (TC-PRISMA) predictions with experimental data obtained from Scanning Electron Micrographs (SEM).



The **3D → 2D** setting is available on a **Plot** or **Table Renderer** that is a successor to the **Precipitation Calculator**, and when certain axis variables are selected for a spherical morphology.

The isothermal coarsening kinetics of γ' precipitates in a Ni-Al-Cr alloy is modeled. The experimental data is from [2008Sud], which investigates isothermal coarsening kinetics at a temperature of 873 K for up to 264 h.

It is assumed that there are no precipitates in solution at the beginning of the isothermal heat treatment.

Project File Information

- Folder: **Precipitation Module - TC-PRISMA**
- File name: `P_16_Precipitation_Ni-Al-Cr_Stereology.tcu`

Example Settings



The example also includes an Equilibrium Calculator and Table Renderer to first confirm the stability of the precipitate phase for this system (FCC_L12#2), then determine particle composition at 1073 K, and this information is used with the Precipitation Calculator set up.

System (System Definer)

Database
package

Demo: Nickel-based superalloys (NIDEMO and MNIDEMO)

Elements	Ni, Al, Cr
Conditions (Precipitation Calculator)	
Composition	Ni-10I-8.5Cr Mole percent
Matrix Phase	DIS_FCC_A1 <ul style="list-style-type: none">Click Show Details and for the Mobility adjustment enter 0.5 for the Prefactor.All other defaults are kept.
Precipitate Phase	FCC_L12#2 Click Show Details and adjust the default settings as indicated: <ul style="list-style-type: none">Interfacial energy: Select User-defined and enter 0.01 J/m².
Calculation Type (Precipitation Calculator)	
Calculation Type	Isothermal
Temperature	1073 Kelvin
Simulation time	300 h
Datasets (Experimental File Reader)	
2008 Sudbrack et al	Data sets are included with this example and are imported using the Experimental File Reader activity. There are 2D size distributions comparing results after a total of 16 h aging, 64 h aging, and 264 h of aging, and a comparison of the experimental and predicted 2D mean radius versus time.

Visualizations



Many of our Graphical Mode examples have video tutorials, which you can access in a variety of ways. When in Thermo-Calc, from the menu select **Help** → **Video Tutorials**, or from the main My Project window, click **Video Tutorials**. Alternately, you can go to the [website](#) or our [YouTube channel](#).

Open the example project file to review the node setup on the **Project** window and the associated settings on the **Configuration** window for each node. For some types of projects, you can also adjust settings on the **Plot Renderer Configuration** window to preview results before performing the simulation. Click **Perform Tree** to generate plots and tables to see the results on the **Visualizations** window.

There is a variety of information shown in the **Visualizations** window that can be viewed during configuration and after performing the calculation.

- **Thermal Profile:** When setting up a calculator on a **Configuration** window for **Isothermal** or **Non-isothermal Calculation Types**, you can preview the profile and adjust settings as needed. When you click a calculator node in the **Project** window, the matching name of the node is on the tab(s) displayed in the **Visualizations** window.



For **TTT Diagram** and **CCT Diagram** calculations there is nothing shown for the Precipitation Calculator tab in the **Visualizations** window as there is no Thermal Profile to be defined.

- **Plot or Table** results: After completing the set up and performing the calculation, to view the matching name of the node on tab(s) in the **Visualizations** window, either click a **Plot Renderer** or **Table Renderer** node in the **Project** window or click the tabs individually in the **Visualizations** window.



For this **Isothermal** example, its **Thermal Profile** is also displayed in the **Visualizations** window showing the constant temperature entered for this calculation type. The tab names match the node names in the **Project** window.

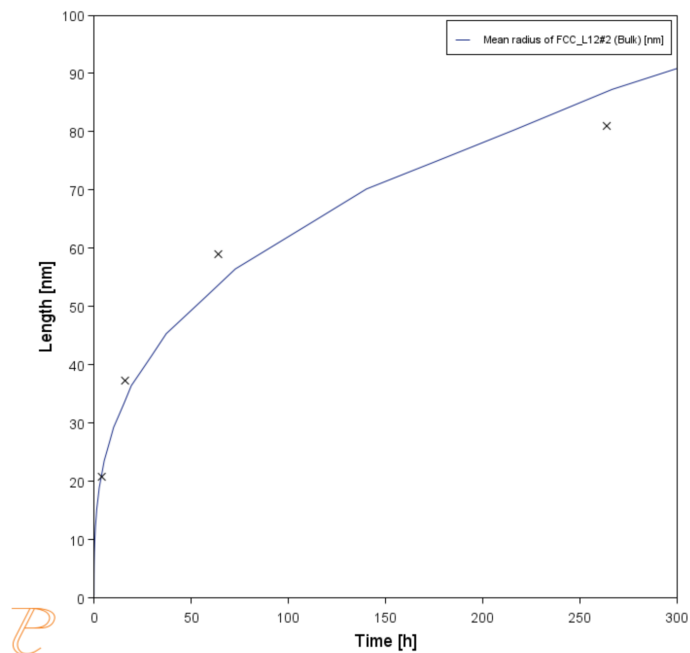

Figure 234: A comparison of the evolution of the mean 2D precipitate radius measurements of [2008Sud] with model predictions.

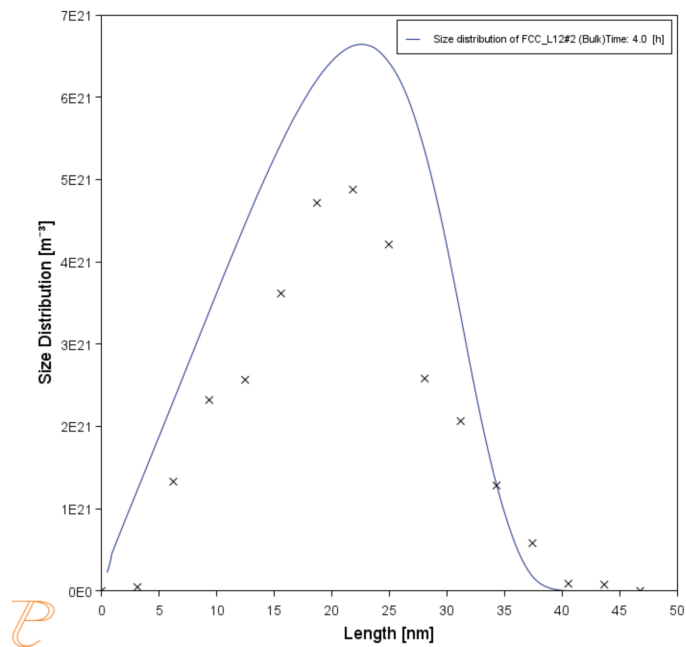

Figure 235: A comparison of the predicted and measured 2D size distribution after 4 h of aging.

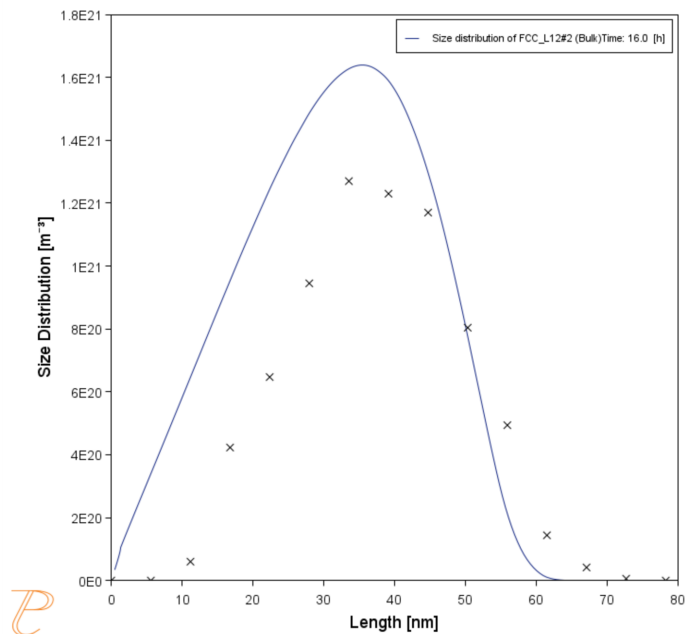

Figure 236: A comparison of the predicted and measured 2D size distribution after 16 h of aging.

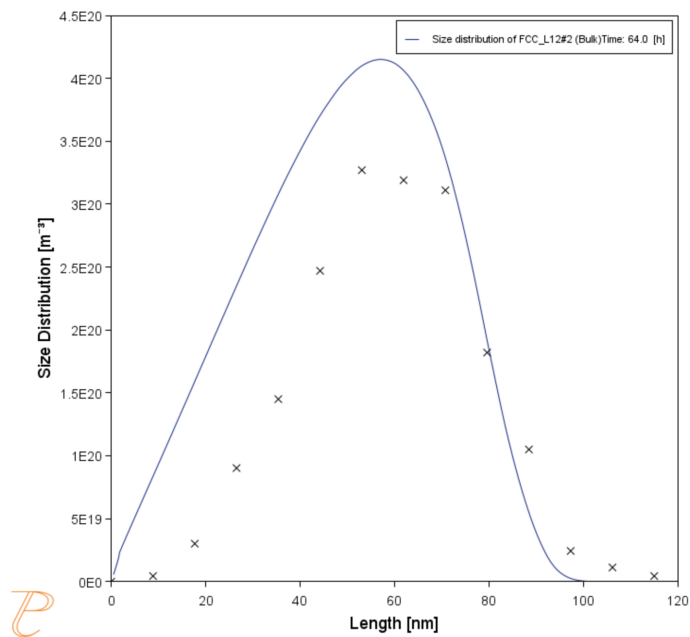

Figure 237: A comparison of the predicted and measured 2D size distribution after 64 h of aging.

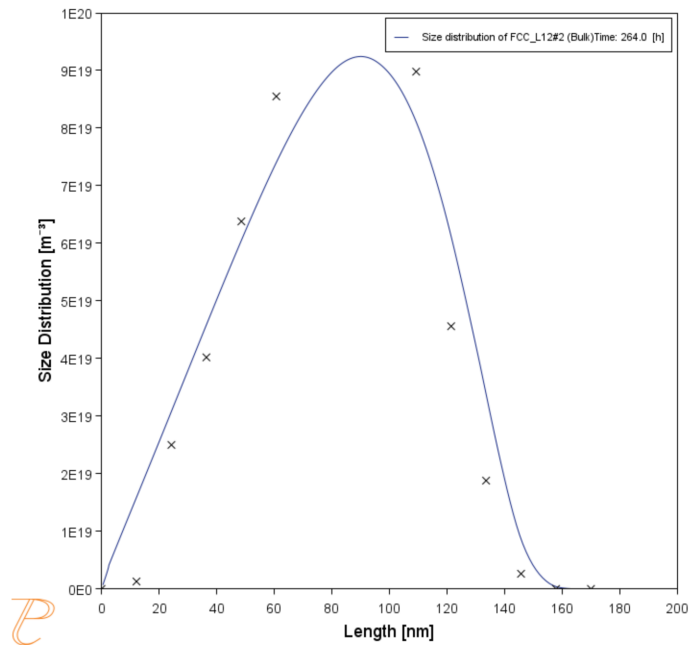

Figure 238: A comparison of the predicted and measured 2D size distribution after 264 h of aging.

Reference

[2008Sud] C. K. Sudbrack, T. D. Ziebell, R. D. Noebe, D. N. Seidman, Effects of a tungsten addition on the morphological evolution, spatial correlations and temporal evolution of a model Ni–Al–Cr superalloy. *Acta Mater.* 56, 448–463 (2008).

Process Metallurgy Module Examples Collection



The Process Metallurgy Module requires both a valid Maintenance and Support Subscription (M&SS) and a license for the TCS Metal Oxide Solutions Database (TCOX8 or newer).



All users can test the Process Metallurgy Module with the included OXDEMO database, which is limited to these elements: Al, C, Ca, Fe, O, S, and Si. For more information about this and other products [visit our website](#).

In this section:

PMET_01: Basic Oxygen Furnace (BOF)	353
PMET_02: Desulphurization in a Ladle Furnace (LF)	355
PMET_03: Argon Oxygen Decarburization (AOD)	357
PMET_04: Basic Oxygen Furnace (BOF) Kinetics	364
PMET_05: Lab Scale Ladle Furnace (LF) Kinetics	366
PMET_06: Ladle Furnace (LF) Kinetics	371
PMET_07: Vacuum Oxygen Decarburization Kinetics	374
PMET_08: Steel Deoxidation on Tapping	376

PMET_01: Basic Oxygen Furnace (BOF)

The example uses the **Process Metallurgy Calculator** to demonstrate a simplified steelmaking process in a Basic Oxygen Furnace (BOF).

This application example in its various forms is [available on our website](#). There are two application examples (one equilibrium, one kinetic) showing how the Process Metallurgy Module can be used to calculate the BOF process.

This basic example uses equilibrium calculations to gain a general understanding of your BOF process and help you determine optimal operation conditions and predict and optimize costs of raw materials and recycling. The other set of examples gives detailed instructions on how to simulate the kinetics of the BOF process using the kinetic process simulation (see "PMET_04: Basic Oxygen Furnace (BOF) Kinetics" on page 364).

Project File and License Information

- Folder: **Process Metallurgy**
- File name: `PMET_01_Basic_Oxygen_Furnace.tcu`



Choose a, b, or c versions of the example based on your license.

- **PMET_01a_Basic_Oxygen_Furnace** is included in a regular Thermo-Calc installation as well as the free Educational version of Thermo-Calc. This is a highly simplified example and uses the OXDEMO database, and only considers the elements Fe, C, and O.
- **PMET_01b_Basic_Oxygen_Furnace** is also a simplified calculation but uses the OXDEMO database. It requires a full license of Thermo-Calc 2021b and newer.
- **PMET_01c_Basic_Oxygen_Furnace** requires the TCOX11 database and newer and a full license of Thermo-Calc 2021b and newer.

Visualizations



This example is included as a Process Metallurgy tutorial on our [website](#) and as part of the playlist our [YouTube channel](#).



The resulting plots and details related to setting up this example are available to download via the [dedicated web page](#).

PMET_02: Desulphurization in a Ladle Furnace (LF)

The example, which is also [available on our website](#), uses the **Process Metallurgy Calculator** to demonstrate the use of a Ladle Furnace (LF) with the Process Metallurgy Module.

The ladle furnace (LF) fulfils many purposes in the steelmaking process. Desulphurization, which we will focus on in this example, is merely one of them.

Desulphurization is usually performed by transferring S that is dissolved in the liquid metal to a CaO-rich slag phase. For this process to be successful, two conditions need to be fulfilled:

1. The slag must be fully liquid (liquid fraction > 0.9). This is required for kinetic reasons. The slag phase must be fluid so that it can emulsify with the liquid steel and form a large surface area where the reaction between steel and slag can take place.
2. The slag must take up a large amount of S from the liquid steel (have a “high sulphur capacity”) so that a significant amount of sulphur will move from the liquid steel to the slag phase.

The example demonstrates how the Process Metallurgy Module in Thermo-Calc can be used to explore these two conditions for an equilibrium between liquid steel and slag in a ladle furnace, trying to find good slag compositions. We also investigate why excessive slag carry-over from the BOF or EAF is detrimental for desulphurization in the LF and how slag conditioning with CaC_2 as fluxing agent can recover the desulphurizing ability of the slag.

Project File and License Information

- Folder: **Process Metallurgy**
- File names: `PMET_02a_Ladle_Furnace.tcu` OR `PMET_02b_Desulphurization_in_Ladle_Furnace.tcu`.



Choose a or b versions of the example based on your license

- `PMET_02a_Ladle_Furnace.tcu` can be run with OXDEMO database but requires the full license for Thermo-Calc 2021b and newer.
- `PMET_02b_Desulphurization_in_Ladle_Furnace.tcu` requires the TCOX11 database and a full license for Thermo-Calc 2021b and newer.

Visualizations



This example is included as a Process Metallurgy tutorial on our [website](#) and as part of the playlist our [YouTube channel](#).



The resulting plots and details related to setting up this example are available to download via the [dedicated web page](#).

PMET_03: Argon Oxygen Decarburization (AOD)

The Argon Oxygen Decarburization (AOD) process is a converter process applied in stainless steel making. In this process the oxidation of chromium in the steel melt needs to be prevented while carbon is oxidized. This is achieved by reducing the oxygen partial pressure by having a high Ar-content in the blowing gas. It is a highly exothermic process that requires adiabatic modeling. In this example the conversion of carbon-rich steel scrap is modeled together with additions of Ferronickel and Ferrochrome to a stainless steel. The example uses the **Process Metallurgy Calculator**.



Visit the website [Application Examples → Process Metallurgy](#) page for more background information as well as more in depth analyses of this and other examples. Also visit the [Process Metallurgy Module](#) page to access resources such as training videos, presentations, publications, webinars, and much more.

Project File and License Information

- Folder: **Process Metallurgy**
- File name: `PMET_03_Argon_Oxygen_Decarburization.tcu`



This example requires a license to run the simulation. It works with TCS Metal Oxide Solutions Database (TCOX) versions 8 and newer.

Visualizations



Many of our Graphical Mode examples have video tutorials, which you can access in a variety of ways. When in Thermo-Calc, from the menu select **Help → Video Tutorials**, or from the main My Project window, click **Video Tutorials**. Alternately, you can go to the [website](#) or our [YouTube channel](#).

Open the example project file to review the node setup on the **Project** window and the associated settings on the **Configuration** window for each node. For some types of projects, you can also adjust settings on the **Plot Renderer Configuration** window to preview results before performing the simulation. Click **Perform Tree** to generate plots and tables to see the results on the **Visualizations** window.



When you run (Perform) this example, it takes a few minutes for the calculations to complete.

Background Description

The AOD-process is characterized by an initially high O₂-content of the blowing gas, which is gradually replaced by Ar. The maximum temperature of the process is typically around 1720 °C. A grid plot of an adiabatic calculation is well suited to model the required simultaneous change of amount of gas and its composition during this process. The black line in the plot above indicates a possible process control path that finally leads to suitable alloy composition close to a X5CrNi 18-10 stainless steel.

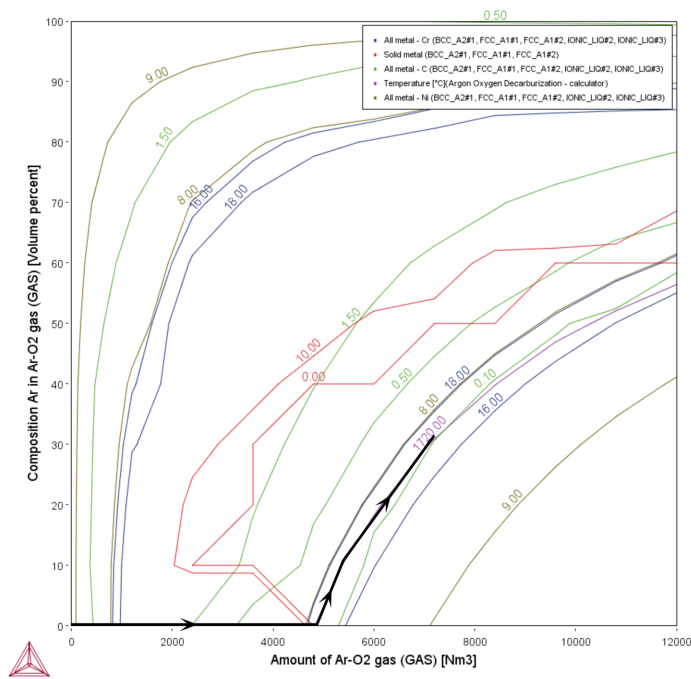

In principle, this plot could be used to control the blowing gas flow in a plant process. However, note that the simulation only considers a global gas phase, i.e. additional gas is added but never removed. This means that the given gas phase composition is an average one and not identical to the composition of the gas flowing in at each point in time. Additionally there is a certain impact on the resulting equilibria from the fact that all gas remains in the system and is not removed.

Slag Basicity

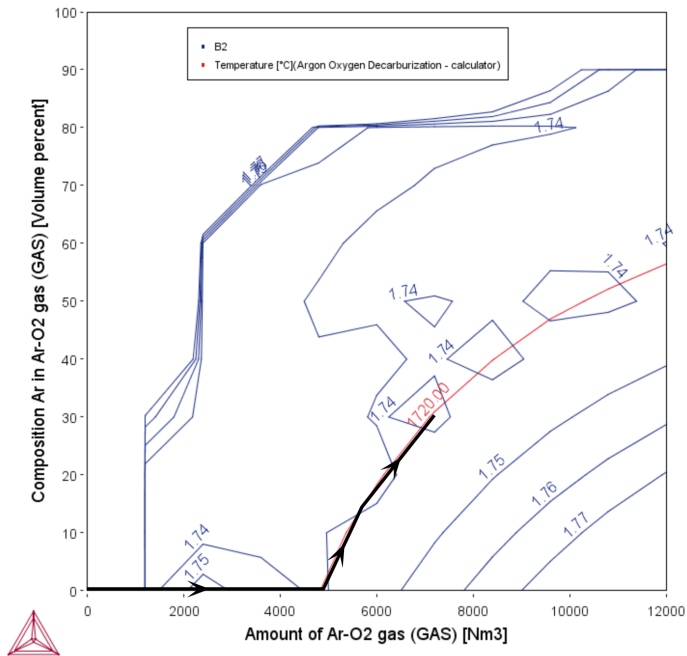

Figure 239: The Slag Basicity plot shows the basicity of the slag (which is a measure for the sulphur capacity of the slag). The process achieves a final basicity of 1.74 which is typical for an AOD-process. The black line in the plot indicates a possible process control path that finally leads to suitable alloy composition close to a X5CrNi 18-10 stainless steel.

S Content in Steel

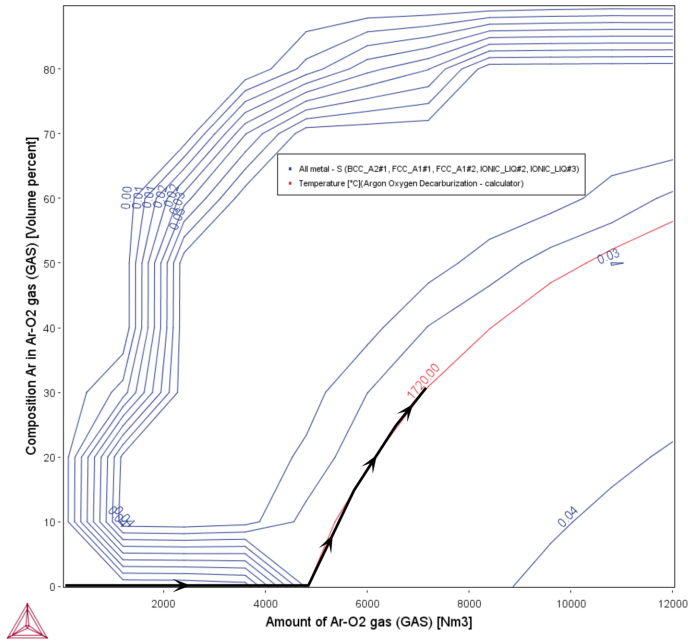

Figure 240: In the S Content in Steel plot, the sulphur content in the steel melt is slightly reduced during the process from 0.056% in the initial steel scrap to finally ca. 0.035%. The black line in the plot indicates a possible process control path that finally leads to suitable alloy composition close to a X5CrNi 18-10 stainless steel.

Cr Content in Slag

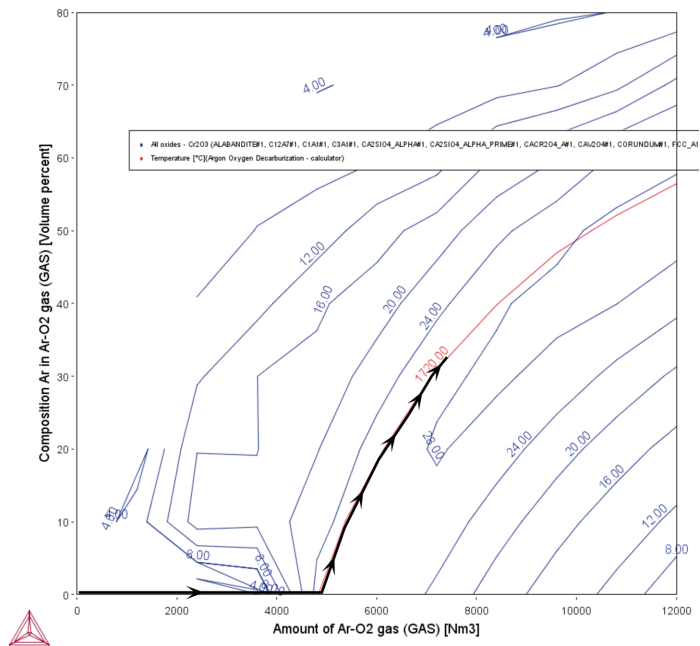

Figure 241: In the Cr Content in Slag plot, the Cr₂O₃-content in the slag reaches at the end of the process ca. 26 wt-%. This is typical for the AOD-process and requires an additional Cr-recovery step after the conversion to reduce the loss of chromium. The black line in the plot indicates a possible process control path that finally leads to suitable alloy composition close to a X5CrNi 18-10 stainless steel.

Amount of Slag

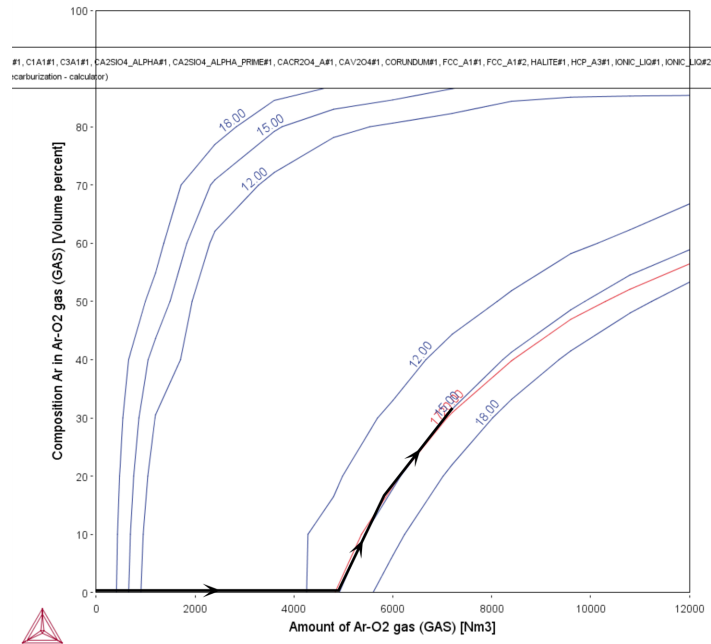

Figure 242: In the Amount of Slag plot, you can see that the process generates about 15 tons of slag in the total. The black line in the plot indicates a possible process control path that finally leads to suitable alloy composition close to a X5CrNi 18-10 stainless steel.

Liquid Slag Fraction

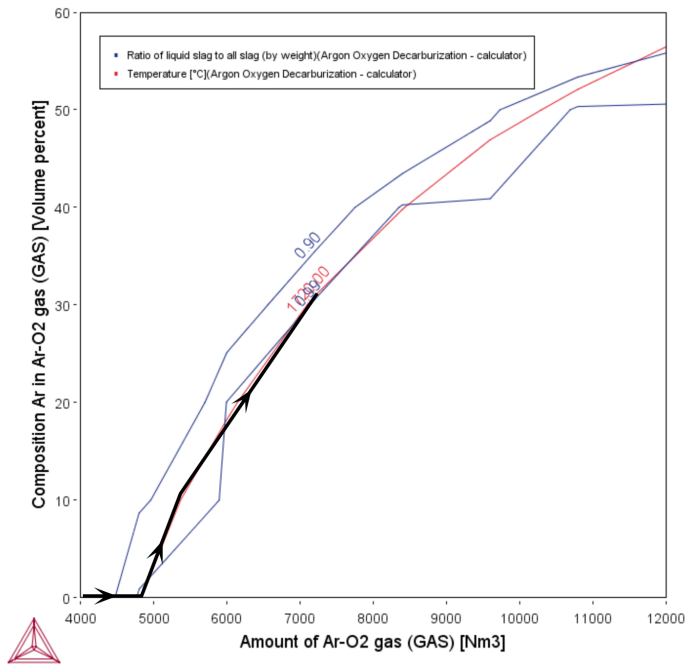

Figure 243: In the Liquid Slag Fraction plot, you can see that towards the end of the process the slag is calculated to be mostly liquid. The black line in the plot indicates a possible process control path that finally leads to suitable alloy composition close to a X5CrNi 18-10 stainless steel.

PMET_04: Basic Oxygen Furnace (BOF) Kinetics

The example uses the **Process Metallurgy Calculator** to simulate the kinetics of the Basic Oxygen Furnace (BOF) process. This application example in its various forms is [available on our website](#).

Metallurgical processes such as the BOF process rarely reach equilibrium. Therefore, a model description must include kinetics if meaningful results are to be obtained. In recent years, a simple but powerful model termed the Effective Equilibrium Reaction Zone (EERZ) model has been developed and widely applied to simulate various metallurgical processes.

This example shows you how to set up a kinetic simulation of the BOF process in the Process Metallurgy Module and includes a description of the EERZ model. For information about the equilibrium examples, see "PMET_01: Basic Oxygen Furnace (BOF)" on page 353.

Project File Information

- Folder: **Process Metallurgy**



Choose a, b, or c versions of the example based on your license.

- `PMET_04a_Basic_Oxygen_Furnace_Kinetics` is included in a regular Thermo-Calc installation as well as the free Educational version of Thermo-Calc. This only considers the elements Fe, C, and O.
- `PMET_04b_Basic_Oxygen_Furnace_Kinetics` needs a full license of Thermo-Calc 2021b or newer, but uses the free OXDEMO database. It considers the elements Fe, C, O, Ca, Al, Si, and S.
- `PMET_04c_Basic_Oxygen_Furnace_Kinetics` requires both a full license of Thermo-Calc 2021b or newer and a license for the TCOX11 database and newer. This simulation corresponds pretty much to a real BOF process with the elements Fe, Mn, C, O, Ca, Al, Mg, Si, S, and P considered.

Visualizations



Many of our Graphical Mode examples have video tutorials, which you can access in a variety of ways. When in Thermo-Calc, from the menu select **Help** → **Video Tutorials**, or from the main My Project window, click **Video Tutorials**. Alternately, you can go to the [website](#) or our [YouTube channel](#).

Open the example project file to review the node setup on the **Project** window and the associated settings on the **Configuration** window for each node. For some types of projects, you can also adjust settings on the **Plot Renderer Configuration** window to preview results before performing the simulation. Click **Perform Tree** to generate plots and tables to see the results on the **Visualizations** window.



The resulting plots and details related to setting up this example are available to download via the [dedicated web page](#).

PMET_05: Lab Scale Ladle Furnace (LF) Kinetics

Using the **Process Metallurgy Calculator** and the **Process simulation** branch, this example is based on the publication by Piva et al [2017Piv] where a lab scale sample of pure iron is first deoxidized with Si-Mn and then a synthetic top slag is added to the steel. Generally, by using the project file and the information below, you can get an idea about how to set up a ladle furnace simulation using the Process Metallurgy Module.



Visit the website [Application Examples → Process Metallurgy](#) page for more background information as well as more in depth analyses of this and other examples. Also visit the [Process Metallurgy Module](#) page to access resources such as training videos, presentations, publications, webinars, and much more.

Project File and License Information

- Folder: **Process Metallurgy**
- File name: `PMET_05_Lab_Scale_Ladle_Furnace_Kinetics.tcu`



This example is best run with the TCS Metal Oxide Solutions Database (TCOX) version 13 or newer and a full license of Thermo-Calc 2024a or newer. Running the example with earlier versions of the database is possible but the results are not consistent with the referenced paper.

Visualizations

Open the example project file to review the node setup on the **Project** window and the associated settings on the **Configuration** window for each node. For some types of projects, you can also adjust settings on the **Plot Renderer Configuration** window to preview results before performing the simulation. Click **Perform Tree** to generate plots and tables to see the results on the **Visualizations** window.



When you run (Perform) this example, it takes a few minutes for the calculations to complete.

About the Plot Results

Many different aspects of the reactions taking place in the LF can be plotted and analyzed. After you run the project file and obtain the plots, you can experiment by adjusting the settings on each Plot Renderer to see what happens in each case. There is more analysis about this and other examples available at the links to our website.



For an example of a more realistic industry scale, see "PMET_06: Ladle Furnace (LF) Kinetics" on page 371.

Setting Up the LF Process Simulation

In the paper by Piva et al. [2017], it is experimentally investigated how the steel and inclusion composition changes in function of time as the Si-Mn killed steel reacts with the slag. This experiment can serve as a model for the production of SiMn killed steel with subsequent top-slag deoxidation.

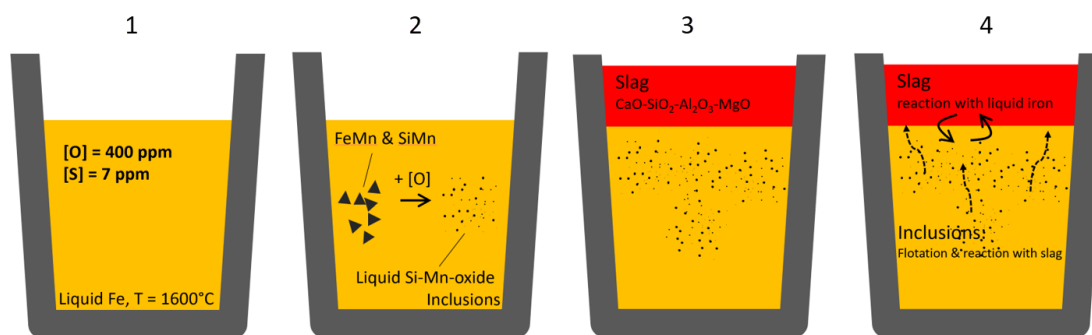

Figure 244: Diagram of the experiment performed by Piva et al. [2017]. The sequence as described in the text is: (1) liquid Fe with dissolved oxygen; (2) FeMn and SiMn added to deoxidize Fe; (3) top slag added after 360s; and (4) gradual reaction between steel, slag and inclusions.

According to the publication the following reaction sequence is expected as shown in the diagram:

1. In the initial state the steel contains 400 ppm of dissolved oxygen.
2. The deoxidizing agents are added. They dissolve and react with the oxygen in the steel forming oxide inclusions, thereby reducing the amount of dissolved oxygen ("killing" the steel). The kinetics are fast, and it can be assumed that the reaction proceeds to thermodynamic equilibrium.
3. On adding the slag (360 s after step 2, killing the steel) the liquid steel starts reacting with the slag.
4. According to the authors the most important reaction that takes place is the dissolution of Al out of the slag and its transferal into the liquid steel, where it reacts with the inclusions and changes their chemistry. Flotation of the inclusions is assumed to be negligible, due to the small size of the crucible and lack of stirring.



In this example only the last reaction is simulated after adding the slag. The kinetic parameters, compositions of all materials and process schedule are all taken from the publication.

Results and Experimental Analysis

The plots below compare the Al content in the liquid steel with the experimentally determined amount. The bottom plot shows how the Al_2O_3 from the slag phase is gradually reduced to metallic Al that dissolves in the liquid steel.



In this example, only part of the Al in the liquid steel is dissolved as metallic Al. With the Process Metallurgy Module, it is possible to plot both dissolved Al and also total Al.

In the steel industry this fraction of Al in the liquid steel is often termed *dissolved Al*. The rest of the Al reacts with the oxygen in the liquid steel and forms oxide inclusions. The amount of dissolved Al plus the Al bound up in oxide inclusions is often termed *total Al*. The difference between total Al minus dissolved Al is an important measure for the steel cleanliness.

Total Al is what was measured by Piva et al. [2017] and their experimental data are compared to the calculated values below.

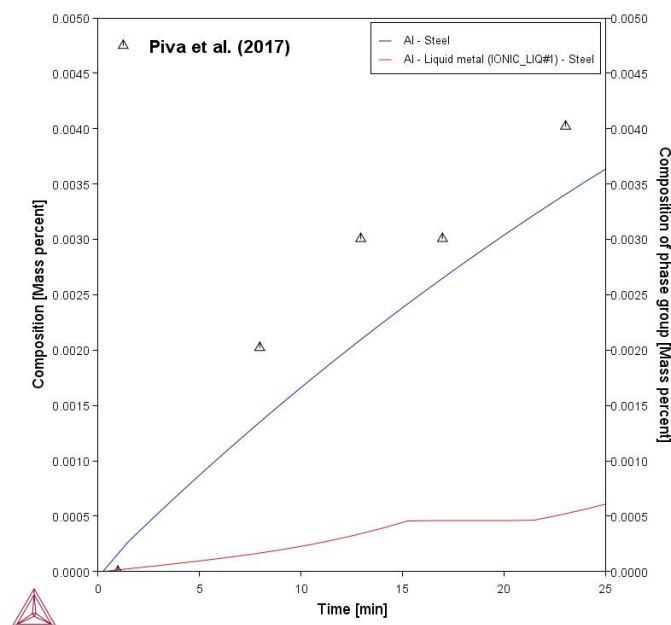

Figure 245: Total Al in the steel compared with experimental data (blue/top curve). Additionally the amount of dissolved Al is plotted (red/bottom curve), this is done by selecting “Composition of phase group” and “Liquid metal”. Note that the red/bottom curve is not available with the example.

Immediately after killing the steel with SiMn and FeMn, the liquid steel contains liquid Si-Mn-oxide inclusions only. As the liquid steel picks up Al from the slag phase in function of time, the inclusions get richer and richer in Al. This experimentally verified change in inclusion chemistry is well reproduced by this simulation.



In the experiment, only the average composition of all inclusions could be measured; the type of inclusion (liquid / solid) was not determined.

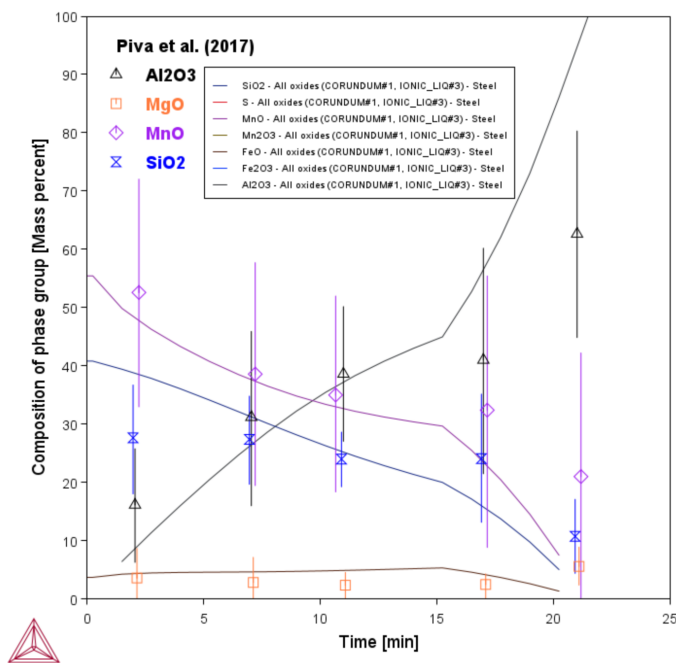

Figure 246: Calculated composition of non-metallic inclusions in function of processing time compared to experimental data [2017Piv].

With this simulation it is also possible to calculate the amount and type of inclusions present in the liquid steel. At the beginning of the process all the inclusions are liquid oxides, that gradually get richer in Al_2O_3 as the steel picks up Al from the slag. After 20 minutes processing time, the first solid corundum (Al_2O_3) inclusions start appearing. After 25 minutes almost no liquid inclusions remain.

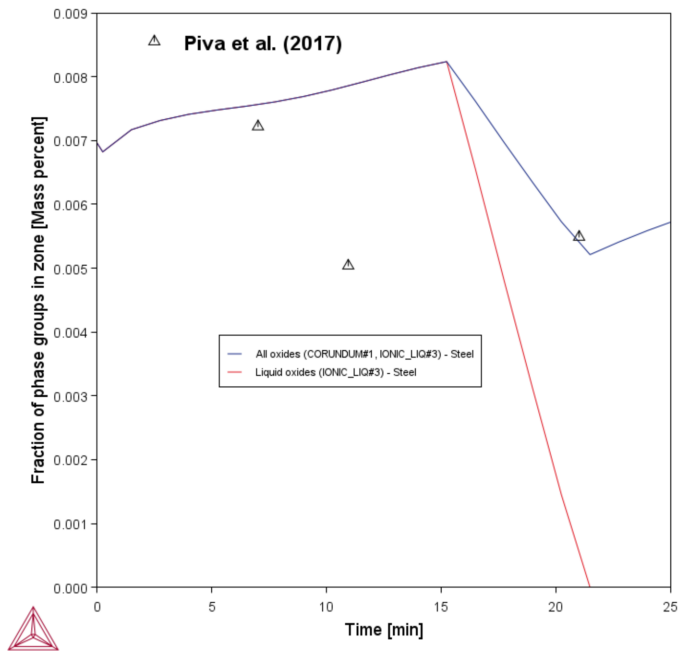

Figure 247: Amount of inclusions in the liquid steel in function of processing time. The total amount of inclusions (red line) and liquid oxide inclusions (blue line) are plotted. Up to about 20 min all inclusions are liquid oxide type, then they are replaced by solid corundum (Al_2O_3) inclusions. Experimental data from [2017Piv].

Reference

[2017Piv] Piva, S. P. T., Kumar, D. & Pistorius, P. C. "Modeling Manganese Silicate Inclusion Composition Changes during Ladle Treatment Using FactSage Macros," Metall. Mater. Trans. B 48, 37–45 (2017).

PMET_06: Ladle Furnace (LF) Kinetics

This in-depth example, which is also [showcased on our website](#), uses the **Process Metallurgy Calculator** to show how to set up a full kinetic simulation of steel refining in a ladle furnace using the Process Metallurgy Module in Thermo-Calc. The Process Metallurgy Module uses the Effective Equilibrium Reaction Zone model (EERZ) to simulate the kinetics of the process. In this example, a full kinetic simulation of the LF refining process is set up using the Process Metallurgy Module.



For a simpler process that describes a lab-scale ladle furnace process, see "[PMET_05: Lab Scale Ladle Furnace \(LF\) Kinetics](#)" on page 366.

Background Overview

After steelmaking, which is mostly performed in a basic oxygen furnace (BOF) or electric arc furnace (EAF), the steel is usually tapped into a ladle where certain additions are made (deoxidation agents, slag formers, certain alloying elements) and then transferred to the ladle furnace (LF). The LF fulfils many purposes in the steel refining process, the most important being:

- Temperature control / heating by an electrical arc.
- Mixing by Ar or N₂ bubbling through porous plugs in the bottom of the ladle to achieve homogeneous temperature and composition throughout the ladle.
- Removal of unwanted non-metallic phases / inclusions such as corundum (Al₂O₃), liquid oxide inclusions, spinel, on so on, by flotation, aided by Ar or N₂ bubbling.
- Modification / engineering of non-metallic inclusions so that they are not detrimental for the downstream processing and/or the final product.
- Removal of unwanted volatile elements such as Pb, Zn, Sn, and so on. Due to their high vapor pressure, these elements are enriched in the rising Ar or N₂ bubbles. After the gas escapes out of the ladle and cools, they condense, forming copious amounts of dust.
- Removal of unwanted elements such as sulphur by liquid steel / slag reactions.
- Lowering of the dissolved gas content. In the LF this is mainly achieved through chemical reactions. For direct removal of dissolved gas, vacuum degassing (VD) is usually required.
- Alloying and trimming of the steel to achieve the exact alloy composition required by the specification of the steel that is to be produced.

The reactions taking place in a LF are a complex interplay between equilibrium thermodynamics that define the direction of chemical reactions, and kinetics that define how fast the equilibrium state is approached.

Project File and License Information

- Folder: **Process Metallurgy**
- File name: `PMET_06_Ladle_Furnace_Kinetics.tcu`



This example requires the database TCOX10 or newer, a full license of Thermo-Calc 2020b or newer, plus a license for the Process Metallurgy Module.

Visualizations



This example is included as a Process Metallurgy tutorial on our [website](#) and as part of the playlist our [YouTube channel](#).

Open the example project file to review the node setup on the **Project** window and the associated settings on the **Configuration** window for each node. For some types of projects, you can also adjust settings on the **Plot Renderer Configuration** window to preview results before performing the simulation. Click **Perform Tree** to generate plots and tables to see the results on the **Visualizations** window.



The resulting plots and details related to setting up this example are available to download via the [dedicated web page](#).

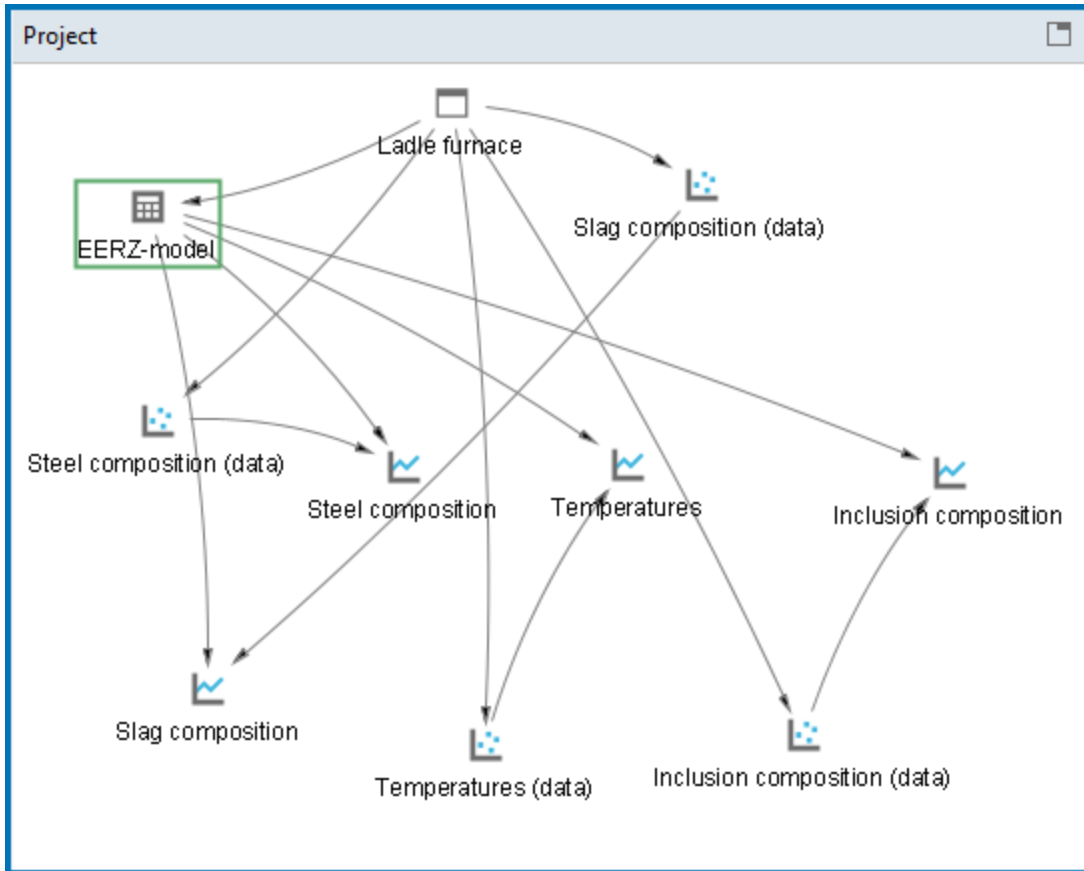

The nodes in the Project window for this example. The Process Metallurgy Calculator is renamed to EERZ model. If you click this node the Configuration window opens, which is where all the settings for the process simulation are located. This advanced example also uses three Experimental Data Reader nodes to read the experimental data that is included in the simulation results. After setting up the system and accessing the experimental data, you then add Plot Renderers to the calculator to generate the output in the Visualizations window.

PMET_07: Vacuum Oxygen Decarburization Kinetics

The vacuum oxygen decarburization (VOD) process is used to lower the carbon content in a stainless steel without compromising on the Cr yield.

This application example, which is [available on our website](#) and uses the **Process Metallurgy Calculator**, shows how the Process Metallurgy Module in Thermo-Calc can be used to simulate the Vacuum Oxygen Decarburization (VOD) process for a stainless steel.

In this example, based on data of a real vacuum oxygen decarburization (VOD) process published by Ding et al. [2000Din], we show how to set up the VOD process in Thermo-Calc's Process Metallurgy Module. Use of the following features in the Process Metallurgy Module are highlighted in this example:

- Change of pressure as a function of time during the process
- Change of reaction kinetics as a function of time during the process
- Selection of zone where degassing is allowed

Project File and License Information

- Folder: **Process Metallurgy**
- File name: `PMET_07_Vacuum_Oxygen_Decarburization_Kinetics.tcu`



This example requires a license for Thermo-Calc 2024a or newer, the database TCOX13 or newer, and a license for the Process Metallurgy Module.

Visualizations



Many of our Graphical Mode examples have video tutorials, which you can access in a variety of ways. When in Thermo-Calc, from the menu select **Help → Video Tutorials**, or from the main My Project window, click **Video Tutorials**. Alternately, you can go to the [website](#) or our [YouTube channel](#).

Open the example project file to review the node setup on the **Project** window and the associated settings on the **Configuration** window for each node. For some types of projects, you can also adjust settings on the **Plot Renderer Configuration** window to preview results before performing the simulation. Click **Perform Tree** to generate plots and tables to see the results on the **Visualizations** window.



The resulting plots and details related to setting up this example are available to download via the [dedicated web page](#).

Reference

[2000Din] R. Ding, B. Blanpain, P. T. Jones, P. Wollants, Modeling of the vacuum oxygen decarburization refining process. Metall. Mater. Trans. B. 31, 197–206 (2000).

PMET_08: Steel Deoxidation on Tapping

This application example, which is [available on our website](#) and uses the **Process Metallurgy Calculator**, shows a few of the ways the Process Metallurgy Module in Thermo-Calc can be used to investigate steel deoxidation (killing) on tapping.

About Deoxidation or “Killing” of Steel

Deoxidation of steel, also known as killing of steel, occurs toward the end of the steelmaking process, but before desulphurization. After primary steelmaking, for example in a basic oxygen furnace (BOF) or electric arc furnace (EAF), the liquid steel contains a large amount of dissolved oxygen [O] (400 to over 1000 ppm.) (see "PMET_04: Basic Oxygen Furnace (BOF) Kinetics" on page 364).

This oxygen must be removed from the liquid steel for several reasons, including:

- Desulphurization is not effective with high oxygen content in the steel
- Continuous casting of un-killed steel is not possible and will result in “boiling” of the steel in the mould and massive porosity.

The two most widely applied methods of deoxidizing or killing the steel are adding Al to the steel (Al-killed steel) and adding Si to the steel (Si-killed steel). In this example we look at how the Process Metallurgy Module in Thermo-Calc can be used to investigate these two widely applied methods of deoxidizing or killing the steel.

The two most widely applied methods of deoxidizing or killing the steel are adding Al (Al-killed steel) to the steel and adding Si (Si-killed steel) to the steel. These elements readily react with oxygen to form oxides that precipitate within the liquid steel. This does not reduce the total amount of oxygen in the liquid steel; it simply transforms the dissolved oxygen into an oxide precipitate. This oxide precipitate then needs to be removed from the steel by flotation during secondary metallurgy in the ladle furnace (LF).

This, however, can result in the formation of damaging inclusions that cause problems during further processing, so we go on to look at two simple and very common processes that are used to transform the solid SiO_2 and Al_2O_3 inclusions into liquid oxides so that they are less damaging.

Project File and License Information

- Folder: **Process Metallurgy**
 - File name: `PMET_08_Steel_Deoxidation_on_Tapping.tcu`
-



Choose a or b versions of the example based on your license.

- `PMET_08a_Steel_Deoxidation_on_Tapping.tcu` is included in a regular Thermo-Calc installation as well as the free Educational version of Thermo-Calc. It is a simplified version that uses the OXDEMO database.
- `PMET_08b_Steel_Deoxidation_on_Tapping.tcu` requires a full license of Thermo-Calc version 2021b or newer and database TCOX11 or newer.

Visualizations



Many of our Graphical Mode examples have video tutorials, which you can access in a variety of ways. When in Thermo-Calc, from the menu select **Help** → **Video Tutorials**, or from the main My Project window, click **Video Tutorials**. Alternately, you can go to the [website](#) or our [YouTube channel](#).

Open the example project file to review the node setup on the **Project** window and the associated settings on the **Configuration** window for each node. For some types of projects, you can also adjust settings on the **Plot Renderer Configuration** window to preview results before performing the simulation. Click **Perform Tree** to generate plots and tables to see the results on the **Visualizations** window.



The resulting plots and details related to setting up this example are available to download via the [dedicated web page](#).

Nickel Model Library Examples Collection



The **General Models** are available to all users. To run calculations with the **Nickel Models** (as part of the Nickel Model Library) requires a valid maintenance license plus licenses for both the TCNI (version 11 and newer) and MOBNI (version 5 and newer) databases.

These examples use the **Property Model Calculator**, an activity available with Thermo-Calc plus the available Property Models in the Nickel Model Library.

In this section:

PM_Ni_01: Lattice Parameter of γ/γ'	379
PM_Ni_02: Antiphase Boundary Energy of γ'	381
PM_Ni_03: Critical Temperatures of Alloy 718	383
PM_Ni_04: Strain Age Cracking (SAC)	385

PM_Ni_01: Lattice Parameter of γ/γ'

The example uses the **Property Model Calculator** with the **Equilibrium with Freeze-in Temperature - Ni** Model.

The lattice parameters are measured experimentally for γ/γ' in a Ni_{0.6}Mo_{0.92}Ta_{12.5}Al_{1.83}Ti_{10.5}Cr_{3.3}W alloy.

The thermodynamically stable equilibrium will not be reached for this alloy during the experimental heat treatment; only the phases γ and γ' are noticed in the experiment. The γ/γ' microstructure is in this calculation example assumed to freeze-in at 1000 °C where the phase compositions do not change during cooling to room temperature.

Some of the key settings to note in this example:

- The **Subset of phases** is selected as **Gamma and gamma-prime only** to match the experimental observations.
- The **Freeze-in temperature** is set to 1000 °C.
- A **One Axis** calculation is used where the evaluation temperatures are within a range of 20 °C to 1000 °C.

Project File and License Information

- Folder: **Property Models** → **Nickel**
- File name: PM_Ni_01_Lattice_Parameter_of_Gamma_Gamma_Prime.tcu



To run calculations with the **Nickel Models** requires a valid maintenance license plus licenses for both the TCNI (version 11 and newer) and MOBNI (version 5 and newer) databases. For some Property Models, additional recommendations for the database version to use is indicated in its description. Also see our website to learn more about the [Nickel Model Library](#).

Visualizations



Many of our Graphical Mode examples have video tutorials, which you can access in a variety of ways. When in Thermo-Calc, from the menu select **Help** → **Video Tutorials**, or from the main My Project window, click **Video Tutorials**. Alternately, you can go to the [website](#) or our [YouTube channel](#).

Open the example project file to review the node setup on the **Project** window and the associated settings on the **Configuration** window for each node. For some types of projects, you can also adjust settings on the **Plot Renderer Configuration** window to preview results before performing the simulation. Click **Perform Tree** to generate plots and tables to see the results on the **Visualizations** window.

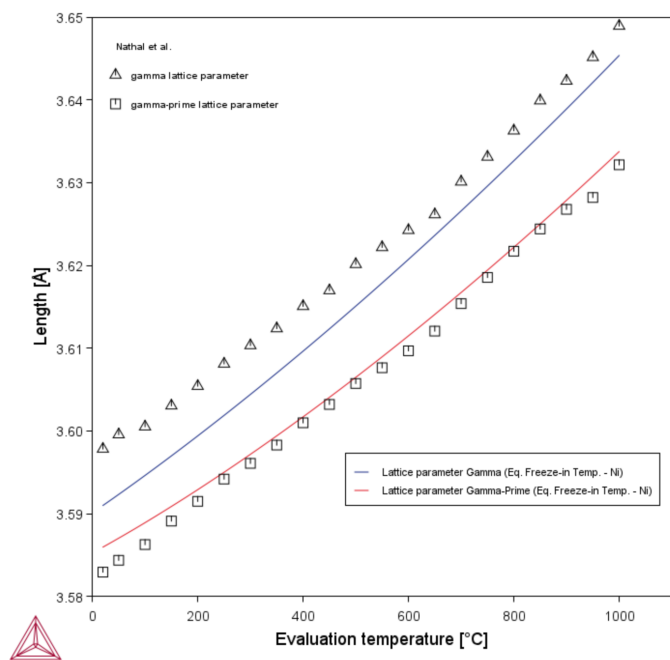

Figure 248: The lattice parameters for γ and γ' are plotted against experimental data from [1985Nat].

Reference

[1985Nat] M. V. Nathal, R. A. Mackay, R. G. Garlick, Temperature dependence of γ - γ' lattice mismatch in Nickel-base superalloys. Mater. Sci. Eng. 75, 195–205 (1985).

PM_Ni_02: Antiphase Boundary Energy of γ'

The example uses the **Property Model Calculator** with the **Antiphase Boundary Energy - Ni Model**.

This example shows a calculation of the antiphase boundary energy for an Al75Ni alloy at room temperature with increasing amounts of Ti. The plot shows the (111) APB energy in $\text{Ni}_3\text{Al}_{1-x}\text{Ti}_x$ over the whole compositional range together with first-principle calculations from Chandran and Sondhi [2011Cha] and Vamsi and Karthikeyani [2012Vam] evaluated at 0 K. The trend with increasing 111 APBE with an increasing amount of Ti is predicted by all calculations but the absolute values between the first principle calculations are quite different.

Some of the key settings to note in this example:

- γ' is the only stable phase for these compositions. FCC_L12 is therefore selected as the only phase in the System Definer.
- The **Freeze-in temperature** and evaluation temperature are both set at 20 °C with the **Subset of phases** for **All phases**.
- A **One Axis** calculation is used with **Mole percent Ti** between 0 and 25 in 20 steps.
- The plotting quantity **APBE for 111 plane (1/2)** is then compared with the first principle calculations.

Project File and License Information

- Folder: **Property Models** → **Nickel**
- File name: `PM_Ni_02_Antiphase_Boundary_Energy_of_Gamma_Prime.tcu`



To run calculations with the **Nickel Models** requires a valid maintenance license plus licenses for both the TCNI (version 11 and newer) and MOBNI (version 5 and newer) databases. For some Property Models, additional recommendations for the database version to use is indicated in its description. Also see our website to learn more about the [Nickel Model Library](#).

Visualizations



Many of our Graphical Mode examples have video tutorials, which you can access in a variety of ways. When in Thermo-Calc, from the menu select **Help** → **Video Tutorials**, or from the main My Project window, click **Video Tutorials**. Alternately, you can go to the [website](#) or our [YouTube channel](#).

Open the example project file to review the node setup on the **Project** window and the associated settings on the **Configuration** window for each node. For some types of projects, you can also adjust settings on the **Plot Renderer Configuration** window to preview results before performing the simulation. Click **Perform Tree** to generate plots and tables to see the results on the **Visualizations** window.

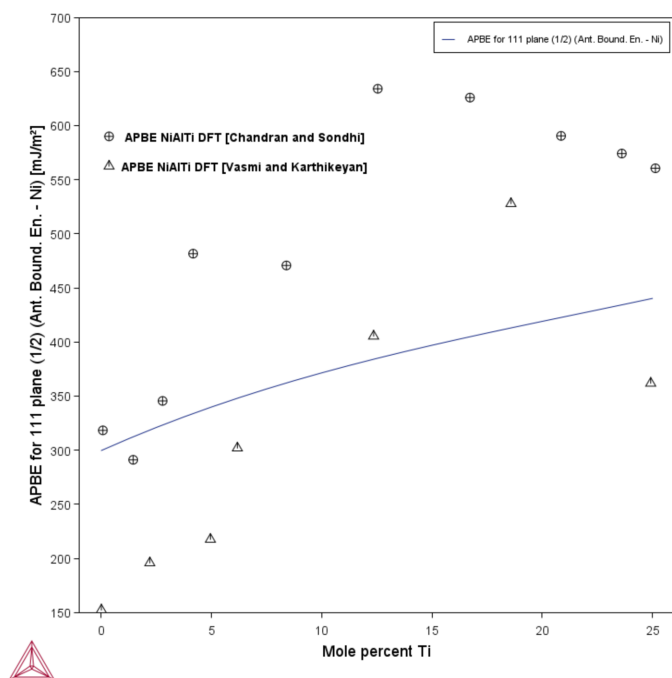

Figure 249: Composition of Ti (mole %) compared to antiphase boundary surface energy for 111 plane and experimental data from [2011Cha; 2012Vam].

References

[2011Cha] M. Chandran, S. K. Sondhi, First-principle calculation of APB energy in Ni-based binary and ternary alloys. *Model. Simul. Mater. Sci. Eng.* 19, 025008 (2011).

[2012Vam] K. V. Vamsi, S. Karthikeyan, Effect of Off-Stoichiometry and Ternary Additions on Planar Fault Energies in Ni₃Al, in *Superalloys 2012* (John Wiley & Sons, Inc., Hoboken, NJ, USA, 2012; pp. 521–530).

PM_Ni_03: Critical Temperatures of Alloy 718

The example uses the **Property Model Calculator** with the **Solvus for Ordered Phase-Ni** Model.

In this example, the respective solvus temperatures of the Delta and Gamma double-prime phases are calculated.

For the Delta phase, the **Subset of phases** is set to **All phases** but the result varies very little with the selected subset (provided that the Delta phase is included). For the Gamma double-prime phase, which is a metastable phase, it is necessary to use the **Typical Ni-base superalloy** phase subset.

The resulting solvus temperatures are compared with experimental data from [2010Fra].

Project File and License Information

- Folder: **Property Models** → **Nickel**
- File name: `PM_Ni_03_Critical_Temperatures_Alloy_718.tcu`



To run calculations with the **Nickel Models** requires a valid maintenance license plus licenses for both the TCNI (version 11 and newer) and MOBNI (version 5 and newer) databases. For some Property Models, additional recommendations for the database version to use is indicated in its description. Also see our website to learn more about the [Nickel Model Library](#).

Visualizations



Many of our Graphical Mode examples have video tutorials, which you can access in a variety of ways. When in Thermo-Calc, from the menu select **Help** → **Video Tutorials**, or from the main My Project window, click **Video Tutorials**. Alternately, you can go to the [website](#) or our [YouTube channel](#).

Open the example project file to review the node setup on the **Project** window and the associated settings on the **Configuration** window for each node. For some types of projects, you can also adjust settings on the **Plot Renderer Configuration** window to preview results before performing the simulation. Click **Perform Tree** to generate plots and tables to see the results on the **Visualizations** window.

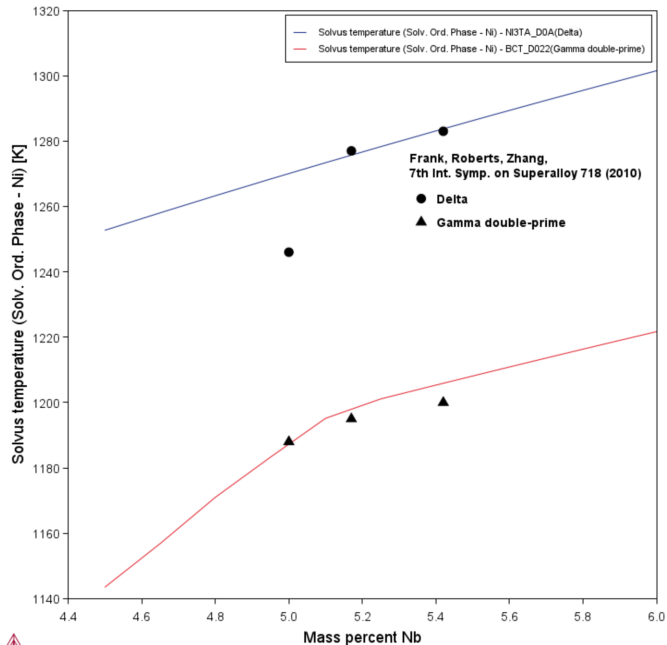

Figure 250: Solvus temperatures for Ni3TA_D0A (Delta) and BCT_D022 (Gamma double-prime) compared to experimental data [2010Fra].

Reference

[2010Fra] R. B. Frank, C. G. Roberts, J. Zhang, Effect of Nickel Content on Delta Solvus Temperature and Mechanical Properties of Alloy 718, in 7th International Symposium on Superalloy 718 and Derivatives (2010) (TMS (The Minerals, Metals & Materials Society), 2010, pp. 725–736.

PM_Ni_04: Strain Age Cracking (SAC)

The example uses the **Property Model Calculator** with the **Strain-Age Cracking - Ni Model**.

Welding or additive manufacturing (AM) of Ni-base alloys has so far been strongly limited by various cracking issues during processing or post-processing. Strain-age cracking (SAC) occurs when the combination of thermal stresses and coherency stresses between the γ matrix and γ' precipitates exceed the local strength of the alloy structure. Thermal residual stresses originate from the initial processing (welding or AM), while coherency stresses form during post-processing heat treatments, when γ' re-precipitates in the matrix. Coherency stresses may be tensile or compressive depending on the sign of the lattice misfit.

Furthermore, coherency stresses scale with the fraction of γ' , making conventional high- γ' alloys virtually impossible to weld or shape via AM. At the same time, high- γ' fraction alloys offer attractive properties, such as high strength at high service temperatures. In order for such alloys to be processable, it is necessary to reduce the cracking tendency.

Thermal stresses are very difficult to alleviate, as this requires heating, which in turn triggers re-precipitation of γ' . Therefore, an alternative strategy may be to target the coherency stresses, which are determined by the respective lattice parameters of the matrix and precipitate. Such a strategy was adopted by Zhou et al. [2020Zho], where they optimized the composition of the Ni-base alloy to fulfill the above criteria, i.e., high fraction of γ' and no strain-age cracking tendency.

In this example, the experimental alloys from [2020Zho] are analyzed based on the **Strain-Age Cracking - Ni Property Model** to compare the tendency for cracking using an SAC risk factor.

Project File and License Information

- Folder: **Property Models** → **Nickel**
- File name: `PM_Ni_04_Strain_Age_Cracking.tcu`



To run calculations with the **Nickel Models** requires a valid maintenance license plus licenses for both the TCNI (version 11 and newer) and MOBNI (version 5 and newer) databases. For some Property Models, additional recommendations for the database version to use is indicated in its description. Also see our website to learn more about the [Nickel Model Library](#).



This example uses TCNI12, but in general can be run with version 11 (TCNI11) and newer databases.

Visualizations



Many of our Graphical Mode examples have video tutorials, which you can access in a variety of ways. When in Thermo-Calc, from the menu select **Help → Video Tutorials**, or from the main My Project window, click **Video Tutorials**. Alternately, you can go to the [website](#) or our [YouTube channel](#).

Open the example project file to review the node setup on the **Project** window and the associated settings on the **Configuration** window for each node. For some types of projects, you can also adjust settings on the **Plot Renderer Configuration** window to preview results before performing the simulation. Click **Perform Tree** to generate plots and tables to see the results on the **Visualizations** window.

Performing the calculation for the two experimental alloys, along with the CM247LC benchmark alloy and using the temperature interval setting produces a set of relevant output results as shown in a table ([Figure 251](#)) and **Parallel coordinates** plot ([Figure 252](#)). CM247LC is considered to be very difficult to weld, which is evidenced by the very high value of the SAC risk factor. Comparatively, the two experimental alloys, ExpAM and ExpAMmod, show values very close to zero. Low or negative values of the SAC risk factor can be interpreted as low or no risk for strain-age cracking.

Conventionally, the *weldability* of a given Ni-base alloy has been assessed based on the Ti and Al contents, which correlate with the fraction of γ' . However, such an approach neglects the fact that it is the coherency stresses that cause cracking, and these are also dependent on the lattice misfit. By tailoring an alloy to have low misfit, in relation to the γ' fraction and in the relevant temperature range, it is possible to design a high- γ' fraction alloy with very low risk for SAC, as shown in [2020Zho]. The SAC model used here captures all of these effects and can be used as a design tool for the purpose of eliminating this cracking tendency.

Visualizations				
Plot Renderer 1	Table Renderer 1			
SAC risk factor	Temperature [K]	Mass percent Ni	Mass percent Al	Mass percent C
0.45355	1000.00000	64.69498	4.00000	5.20000
0.84060	1000.00000	65.39995	4.10000	5.00000
345.11631	1000.00000	61.69999	5.60000	9.20000

Figure 251: There are a two ways to view the data in table format. In this example, there is a Table Renderer node added to the Project window that lists the data points in the Visualizations window.



You can also access the same information via the Plot Renderer Configuration window by clicking the **Table View** button followed by clicking **Perform**. This converts the **Parallel coordinates** plot type to the same table of information.

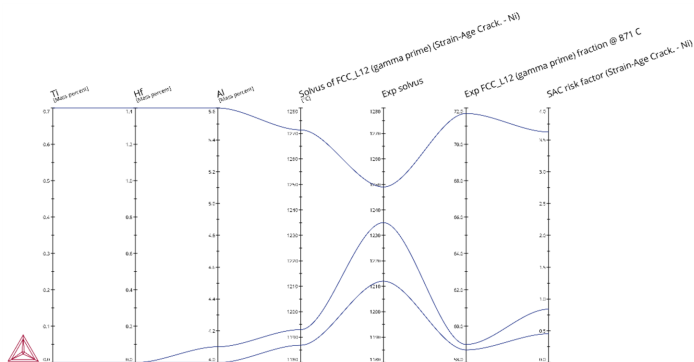

Figure 252: Parallel plot of the resulting SAC risk factor along with experimental and calculated solvus of γ' for the three alloys compared in [2020Zho].

Reference

[2020Zho] N. Zhou, A. D. Dicus, S. A. J. Forsik, T. Wang, G. A. Colombo, M. E. Epler, Development of a New Alumina-Forming Crack-Resistant High- γ' Fraction Ni-Base Superalloy for Additive Manufacturing, in *Superalloys 2020*, pp. 1046–1054.

Noble Metal Alloys Model Library Examples Collection

These examples use the **Property Model Calculator**, an activity available with Thermo-Calc plus the available Property Models in the Noble Metal Alloys Model Library.



The **General Models** are available to all users. To run calculations with the **Noble Metal Alloys Models** (as part of the Noble Metal Alloys Model Library) requires a valid maintenance license plus a license for the TCNOBL (version 3 and newer) database.

In this section:

PM_Noble_01: Color Prediction 389

PM_Noble_01: Color Prediction

The **Optical Properties - Noble** Property Model, available with the Property Model Calculator and the Noble Metal Alloys Model Library, is used to simulate the color, reflection, and transmission of light, based on modeling the alloy microstructure and the resulting optical properties. This model is currently applicable for the Au-Al-Ag-Cu-Pt system.

This example uses the **Property Model Calculator** with the **Optical Properties - Noble** Property Model.

The example demonstrates three use cases for simulating color in the Ag-Au-Cu alloy system (1) screening the color of the alloy system (2) designing a green-gold alloy by adjusting Ag content, and (3) visualizing the impact of alloy thickness and light incident angle on color.

Project File and License Information

- Folder: **Property Models** → **Noble Metals**
- File name: `PM_Noble_01_Color_Prediction.tcu`



To run calculations with the **Noble Metal Alloys Models** (as part of the Noble Metal Alloys Model Library) requires a valid maintenance license plus a license for the TCNOBL (version 3 and newer) database.

Visualizations



Many of our Graphical Mode examples have video tutorials, which you can access in a variety of ways. When in Thermo-Calc, from the menu select **Help** → **Video Tutorials**, or from the main My Project window, click **Video Tutorials**. Alternately, you can go to the [website](#) or our [YouTube channel](#).

Open the example project file to review the node setup on the **Project** window and the associated settings on the **Configuration** window for each node. For some types of projects, you can also adjust settings on the **Plot Renderer Configuration** window to preview results before performing the simulation. Click **Perform Tree** to generate plots and tables to see the results on the **Visualizations** window.

 When you run (Perform) this example, it takes a few minutes for the calculations to complete.

Screening the Color of the Ag-Au-Cu Alloy System

- The entire composition space was screened with a 2 wt.% step size.
- Alloys were annealed at 873.15 K to reach equilibrium phases and compositions for accurate color prediction.
- The standard illuminant is D65 noon daylight, with a 2° standard observer. The material is assumed to be opaque with a thickness of 10,000 nm.
- Some color predictions near the 20–40 wt.% Cu region require model accuracy improvements.

Visualizations 🗒️ 📄

Delta E plot Ternary color plot Angle and thickness dependence Delta E values

ΔE value (Opt. Prop. - Noble)	Mass percent Au	Mass percent Ag	Temperature [K]	Mass percent Cu
28.71022	65.00000	25.00000	900.00000	10.00000
10.13931	64.00000	26.00000	900.00000	10.00000
1.69277	63.00000	27.00000	900.00000	10.00000
1.69277	62.00000	28.00000	900.00000	10.00000

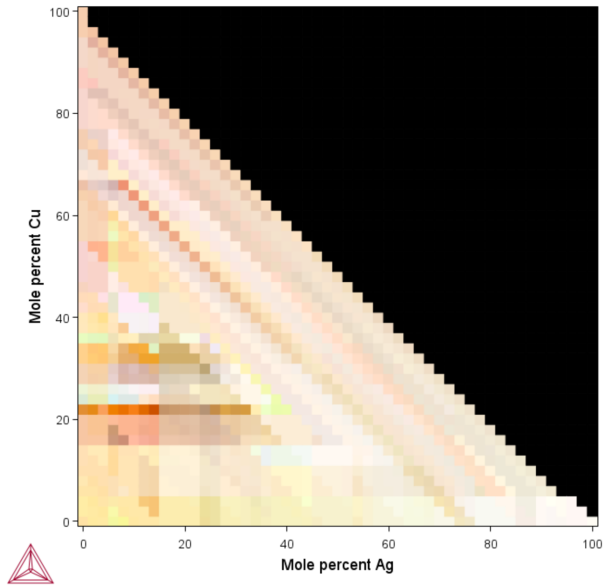

Figure 253: Color prediction for Ag-Au-Cu alloy.

Designing a Green Gold Alloy by Adjusting Ag Content in Au-10Cu-xAg Alloys

- ΔE calculation box was chosen to enable the measurement of color differences.
- Target color in Lab color space is [95, -13, 25], representing a light green shade.

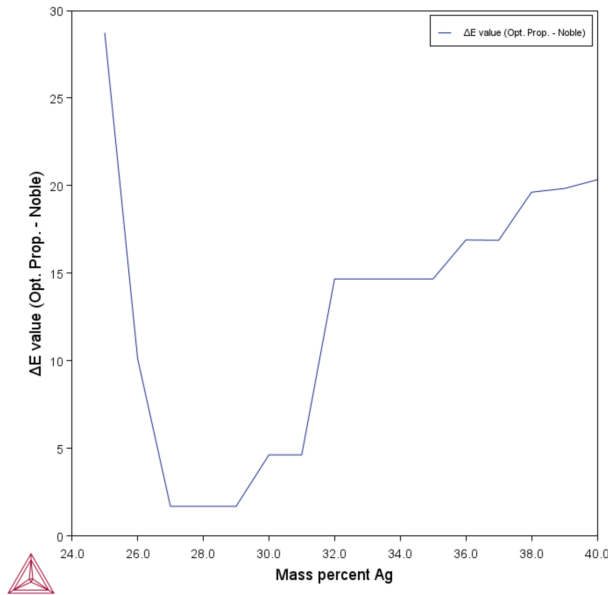

Figure 254: Change of color difference (ΔE) between the targeting light green gold and the simulated alloy when changing Ag content.

Visualizing the Impact of Alloy Thickness and Light Incident Angle on Color

- Intercritical annealing was not selected, as pure gold is in the FCC phase and does not require equilibrium calculations.
- As material thickness increases, the color of gold tends to approach the bulk gold color observed in macroscopic samples.

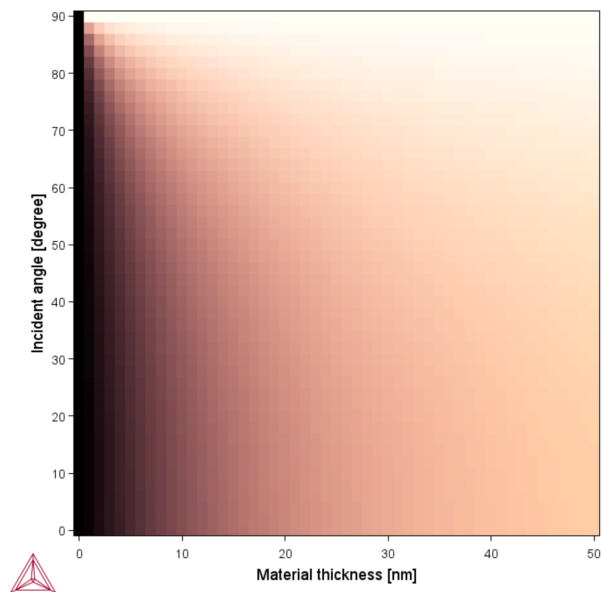

Figure 255: Color of pure gold varies with different light incident angles and material thicknesses.

Steel Model Library Examples Collection



The **General Models** are available to all users. To run calculations with the **Steel Models** (as part of the Steel Model Library) requires a valid maintenance license plus licenses for both the TCFE (version 9 and newer) and MOBFE (version 4 and newer) databases.

These examples use the **Property Model Calculator**, an activity available with Thermo-Calc plus Property Models in the Steel Model Library.

In this section:

PM_Fe_01: Fe-Cr-C Martensite with Intercritical Annealing	394
PM_Fe_02: Fe-Mn Martensite Morphologies	397
PM_Fe_03: Fe-C-Mn Pearlite	399
PM_Fe_04: Critical Temperatures	402
PM_Fe_05: Fe-C-Mn-Si-Ni-Cr-Mo Bainite	405
PM_Fe_06: TTT Diagram for Fe-C-Mn-Si-Cr-V	407
PM_Fe_07: Hardenability Design of Steel	409
PM_Fe_08: CCT Diagram for Fe-C-Mn-Si-Cr-V	411
PM_Fe_09: Fe-C-Ni Ferrite	413
PM_Fe_10: Martensitic Steel Strength	416
PM_Fe_11: Steel Design Using the Parallel Coordinates Plot	420
PM_Fe_12: Flow Stress 15-5PH Steel	423

PM_Fe_01: Fe-Cr-C Martensite with Intercritical Annealing

The example uses the **Property Model Calculator** with the **Martensite Fractions** and **Martensite Temperatures** Models to calculate martensite fractions and martensite temperatures [martensite start (Ms) and 90% transformation temperature (M90)].

The alloy is first intercritically annealed and then quenched. Austenite composition is determined by an equilibrium calculation at the annealing temperature. Martensite fraction is calculated as a function of temperature which the alloy is quenched to. The example also shows how Cr content in the alloy influences Ms and M90 after intercritical annealing.

Project File and License Information

- Folder: **Property Models** → **Steel**
- File name: PM_Fe_01_Fe-Cr-C_martensite_intercritical_annealing.tcu



To run calculations with the **Steel Models** requires a valid maintenance license plus licenses for both the TCFE (version 9 and newer) and MOBFE (version 4 and newer) databases. Also see our website to learn more about the [Steel Model Library](#) and other related examples.

Visualizations



This example is included as a Property Model tutorial on our [website](#) and as part of the Property Model Calculator playlist on our [YouTube channel](#).

Open the example project file to review the node setup on the **Project** window and the associated settings on the **Configuration** window for each node. For some types of projects, you can also adjust settings on the **Plot Renderer Configuration** window to preview results before performing the simulation. Click **Perform Tree** to generate plots and tables to see the results on the **Visualizations** window.

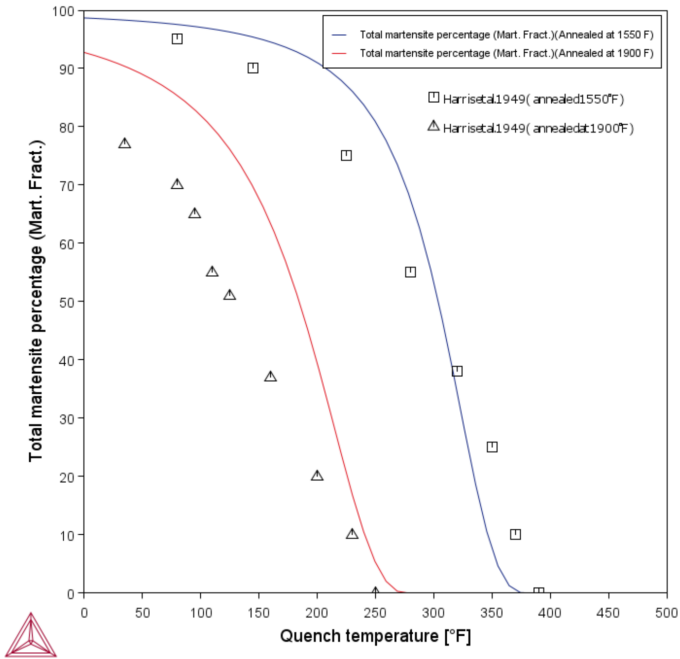

Figure 256: The transformation curves plot showing Fe-Cr-C martensite with intercritical annealing.

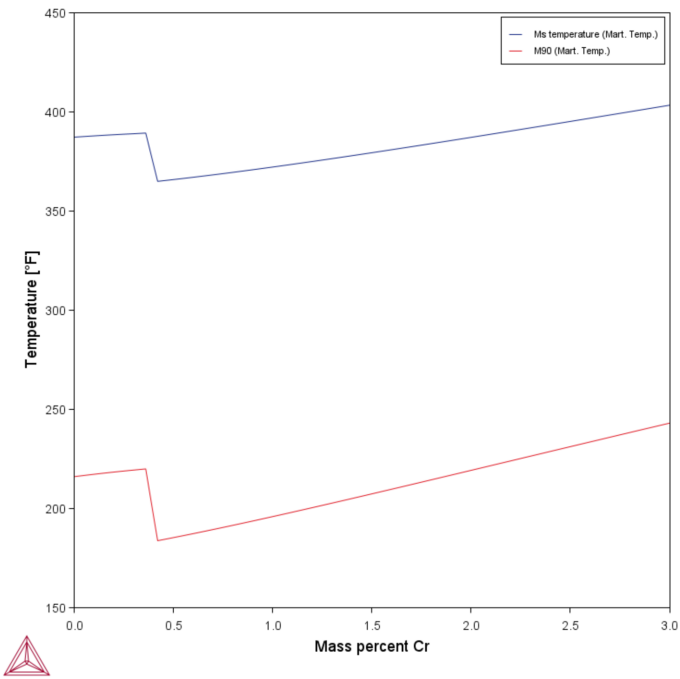

Figure 257: Comparing Martensite start (Ms) to Martensite finish (Mf).

Reference

[1949Har] W. J. Harris, M. Cohen, Stabilization Of The Austenite-Martensite Transformation. Trans. AIME. 180, 447–470 (1949).

PM_Fe_02: Fe-Mn Martensite Morphologies

The example uses the **Property Model Calculator** with the **Martensite Temperatures** Property Model to calculate the Ms temperatures of different types of martensites: lath, plate, and ϵ (HCP), compared with experimental ϵ Ms values taken from several sources.

Project File and License Information

- Folder: **Property Models** → **Steel**
- File name: `PM_Fe_02_Fe-Mn_Martensite_Morphologies.tcu`



To run calculations with the **Steel Models** requires a valid maintenance license plus licenses for both the TCFE (version 9 and newer) and MOBFE (version 4 and newer) databases. Also see our website to learn more about the [Steel Model Library](#) and other related examples.

Visualizations



Many of our Graphical Mode examples have video tutorials, which you can access in a variety of ways. When in Thermo-Calc, from the menu select **Help** → **Video Tutorials**, or from the main My Project window, click **Video Tutorials**. Alternately, you can go to the [website](#) or our [YouTube channel](#).

Open the example project file to review the node setup on the **Project** window and the associated settings on the **Configuration** window for each node. For some types of projects, you can also adjust settings on the **Plot Renderer Configuration** window to preview results before performing the simulation. Click **Perform Tree** to generate plots and tables to see the results on the **Visualizations** window.

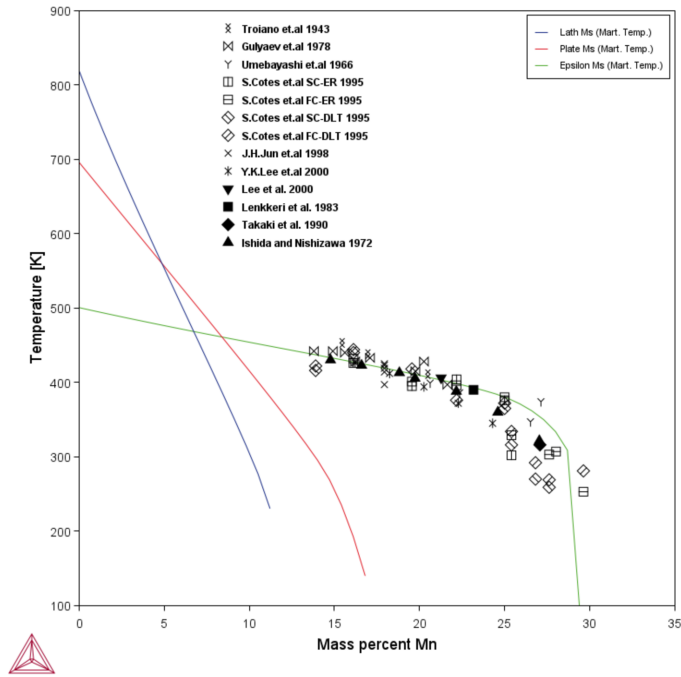

Figure 258: A diagram showing all the Ms temperatures of different types of martensite morphologies (lath, plate and epsilon (HCP) compared with experimental epsilon Ms values.

PM_Fe_03: Fe-C-Mn Pearlite

The example uses the **Property Model Calculator** and with the **Pearlite** Property Model and shows how to calculate pearlite growth rate, lamellar spacing, and times of start (2% transformation) and finish (98% transformation) as functions of isothermal heat treating temperature in an Fe-0.69C-1.80Mn alloy (mass %). With *maximize growth rate* set as the *criterion*, the model gives maximal growth rate and minimal lamellar spacing. With *optimal pearlite* as the *pearlite mode*, the model optimizes partitioning of substitutional alloying element(s) (Mn in this example) according to the criterion, which realizes a smooth transition between ortho-pearlite at high temperature and para-pearlite at low temperature.

Project File and License Information

- Folder: **Property Models** → **Steel**
- File name: `PM_Fe_03_Fe-C-Mn_Pearlite.tcu`



To run calculations with the **Steel Models** requires a valid maintenance license plus licenses for both the TCFE (version 9 and newer) and MOBFE (version 4 and newer) databases. Also see our website to learn more about the [Steel Model Library](#) and other related examples.

Visualizations



Many of our Graphical Mode examples have video tutorials, which you can access in a variety of ways. When in Thermo-Calc, from the menu select **Help** → **Video Tutorials**, or from the main My Project window, click **Video Tutorials**. Alternately, you can go to the [website](#) or our [YouTube channel](#).

Open the example project file to review the node setup on the **Project** window and the associated settings on the **Configuration** window for each node. For some types of projects, you can also adjust settings on the **Plot Renderer Configuration** window to preview results before performing the simulation. Click **Perform Tree** to generate plots and tables to see the results on the **Visualizations** window.

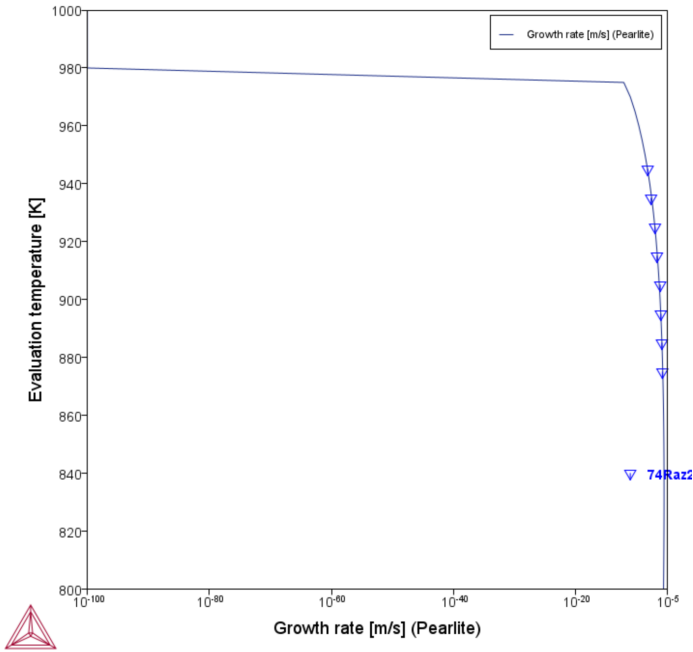

Figure 259: Growth rate as a function of temperature.

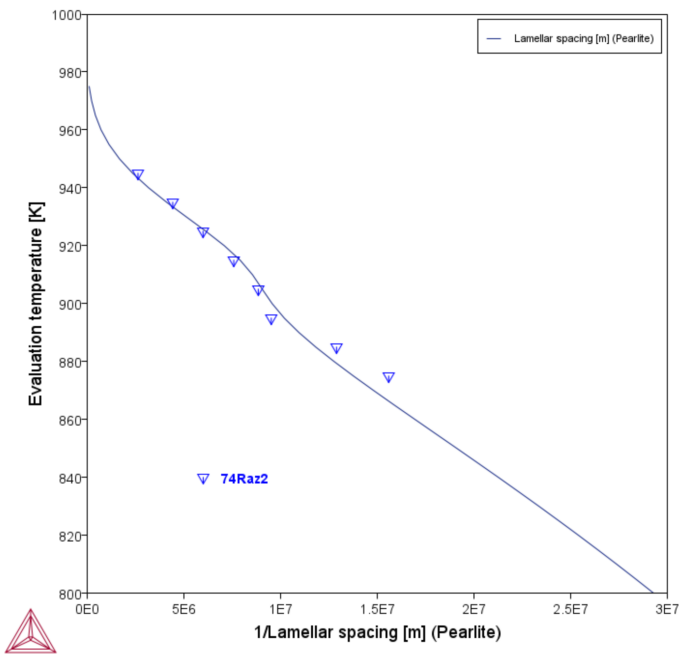

Figure 260: Lamellar spacing as a function of temperature.

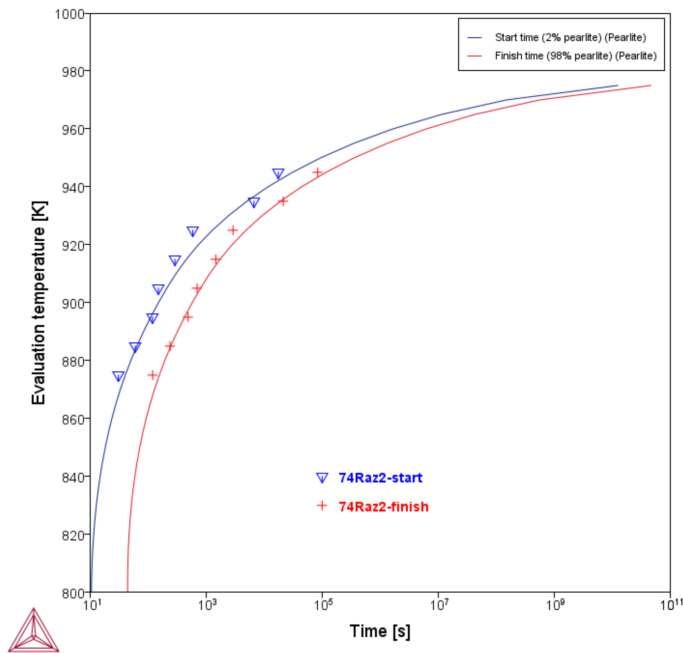

Figure 261: The TTT (time-temperature-transformation) diagram showing times of start (2% transformation) and finish (98% transformation) as functions of isothermal heat treating temperature in an Fe-0.69C-1.80Mn alloy (mass %).

Reference

[1974Raz] N. Razik, G. Lorimer, N. Ridley, An investigation of manganese partitioning during the austenite-pearlite transformation using analytical electron microscopy. *Acta Metall.* 22, 1249–1258 (1974).

PM_Fe_04: Critical Temperatures

The example uses the **Property Model Calculator** and the **Critical Transformation Temperatures** Model to calculate the distribution of the typical phase transition temperatures for a low alloy steel (Fe-0.3Cr-1.0Mn-0.3Mn-0.18C) when the composition is varied within the specification for the alloy.

In the set up of the example, the **Critical Transformation Temperatures** model is used with a Property Model Calculator **Uncertainty** calculation to plot a histogram showing the distribution of A1- and A3-temperatures ([Figure 262](#)). As a comparison, an Equilibrium Calculator, **One Axis** calculation results in a property diagram showing the phase transitions for the nominal composition ([Figure 263](#)).

The phase transition temperatures are defined as:

- Liquidus: First austenite or ferrite transformation from the liquid
- Solidus: Liquid fully transformed to solid
- A0: Magnetic transition temperature (Curie temperature) of cementite. The cementite is paramagnetic above A0 and ferromagnetic below
- A1: Austenite (FCC_A1) transforms to ferrite (BCC_A2) + carbide (cementite or graphite or M23C6)
- A2: Magnetic transition temperature (Curie temperature) of ferrite (BCC_A2). Paramagnetic above A2 and ferromagnetic below
- A3: Austenite (FCC_A1) transforms to ferrite (BCC_A2)

Project File and License Information

- Folder: **Property Models → Steel**
- File name: `PM_Fe_04_Critical_Temperatures.tcu`



The **FEDEMO: Iron Demo Database** is used and this example is available to all users. However, in general a license is required to run the Steel Models.

Visualizations



Many of our Graphical Mode examples have video tutorials, which you can access in a variety of ways. When in Thermo-Calc, from the menu select **Help** → **Video Tutorials**, or from the main My Project window, click **Video Tutorials**. Alternately, you can go to the [website](#) or our [YouTube channel](#).

Open the example project file to review the node setup on the **Project** window and the associated settings on the **Configuration** window for each node. For some types of projects, you can also adjust settings on the **Plot Renderer Configuration** window to preview results before performing the simulation. Click **Perform Tree** to generate plots and tables to see the results on the **Visualizations** window.

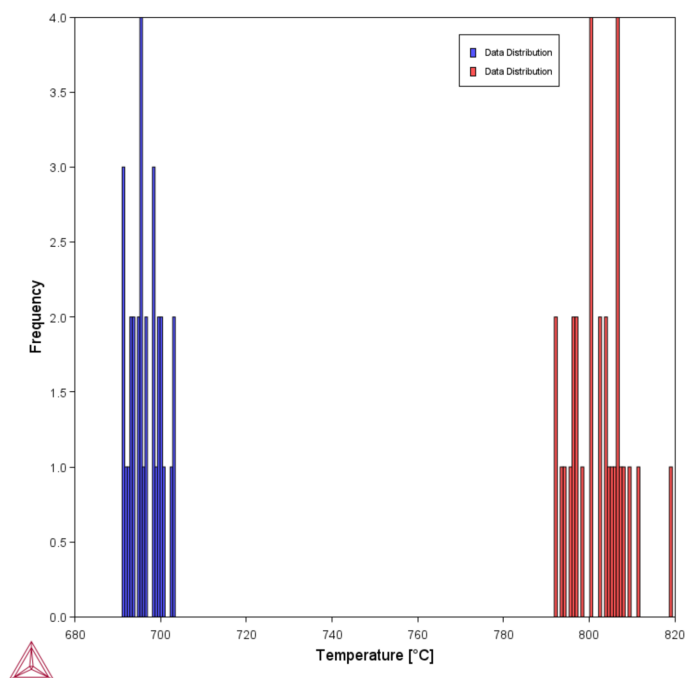

Figure 262: The distribution of the A1 and A3 phase transition temperatures for a low alloyed steel (Fe-0.3Cr-1.0Mn-0.3Mn-0.18C) when the composition is varied within the specification. This plot uses the Critical Transformation Temperatures model with the Property Model Calculator.

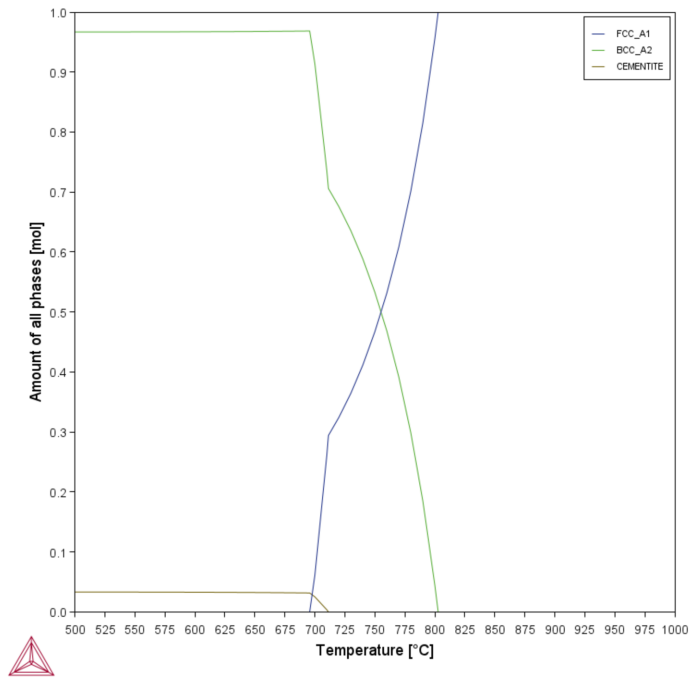

Figure 263: This plot uses an Equilibrium Calculator to show an alternate visualization of the phase transitions in a property diagram for the nominal composition.

PM_Fe_05: Fe-C-Mn-Si-Ni-Cr-Mo Bainite

The example uses the **Property Model Calculator** and the **Bainite** Steel Model to calculate a Time-Temperature-Transformation (TTT) diagram for an Fe-0.97C-0.72Mn-0.32Si-1.54Ni-0.8Cr-0.26Mo alloy. The result is compared to experimental results from [1948Jaf]. Other elements with low amount in the experimental alloy are omitted for the calculation.



Considered elements: Fe, C, Mn, Si, Cr, Ni, and Mo. Other elements in the system are neglected for bainite by mass percent.

A Property Model Calculator is used with a *One Axis* calculation and the *TTT mode* selected on the Plot Renderer to plot the TTT diagram.

Project File and License Information

- Folder: **Property Models** → **Steel**
- File name: `PM_Fe_05_Fe-C-Mn-Si-Ni-Cr-Mo_Bainite.tcu`



To run calculations with the **Steel Models** requires a valid maintenance license plus licenses for both the TCFE (version 9 and newer) and MOBFE (version 4 and newer) databases. Also see our website to learn more about the [Steel Model Library](#) and other related examples.

Visualizations



Many of our Graphical Mode examples have video tutorials, which you can access in a variety of ways. When in Thermo-Calc, from the menu select **Help** → **Video Tutorials**, or from the main My Project window, click **Video Tutorials**. Alternately, you can go to the [website](#) or our [YouTube channel](#).

Open the example project file to review the node setup on the **Project** window and the associated settings on the **Configuration** window for each node. For some types of projects, you can also adjust settings on the **Plot Renderer Configuration** window to preview results before performing the simulation. Click **Perform Tree** to generate plots and tables to see the results on the **Visualizations** window.



When you run (Perform) this example, it takes a few minutes for the calculations to complete.

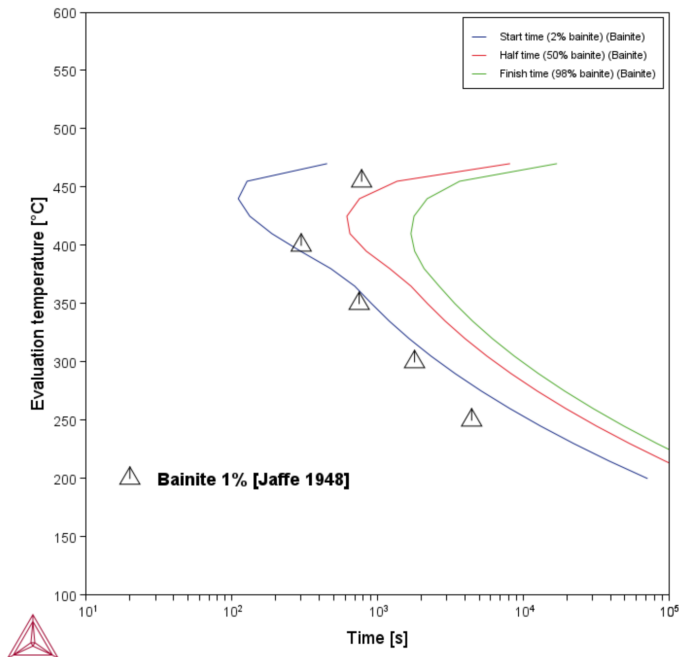

Figure 264: The bainite TTT diagram for an Fe-0.97C-0.72Mn-0.32Si-1.54Ni-0.8Cr-0.26Mo alloy.

Reference

[1948Jaf] L. D. Jaffe, Anisothermal formation of bainite and proeutectoid constituents in steels, Trans. AIME, vol. 176, pp. 343–383 (1948).

PM_Fe_06: TTT Diagram for Fe-C-Mn-Si-Cr-V

The example uses the **Property Model Calculator** and the **TTT Diagram** Property Model to calculate a Time-Temperature-Transformation (TTT) diagram for an Fe-C-Mn-Si-Cr-V alloy (Steel 42CrV6). The calculation is compared to an experimental TTT diagram for the same steel (with some other impurities) from data in [1958Wev].

A **One Axis Calculation Type** is selected on the Property Model Calculator and then the **TTT Mode** selected on the Plot Renderer as the *Plot type* in order to plot the final TTT diagram.

A second plot also shows the calculated terminal fractions of ferrite, pearlite, and bainite.

Project File and License Information

- Folder: **Property Models** → **Steel**
- File name: `PM_Fe_06_Fe-C-Mn-Si-Cr-V_TTT.tcu`



To run calculations with the **Steel Models** requires a valid maintenance license plus licenses for both the TCFE (version 9 and newer) and MOBFE (version 4 and newer) databases. Also see our website to learn more about the [Steel Model Library](#) and other related examples.

Visualizations



Many of our Graphical Mode examples have video tutorials, which you can access in a variety of ways. When in Thermo-Calc, from the menu select **Help** → **Video Tutorials**, or from the main My Project window, click **Video Tutorials**. Alternately, you can go to the [website](#) or our [YouTube channel](#).

Open the example project file to review the node setup on the **Project** window and the associated settings on the **Configuration** window for each node. For some types of projects, you can also adjust settings on the **Plot Renderer Configuration** window to preview results before performing the simulation. Click **Perform Tree** to generate plots and tables to see the results on the **Visualizations** window.



When you run (Perform) this example, it takes several hours to complete the calculations.

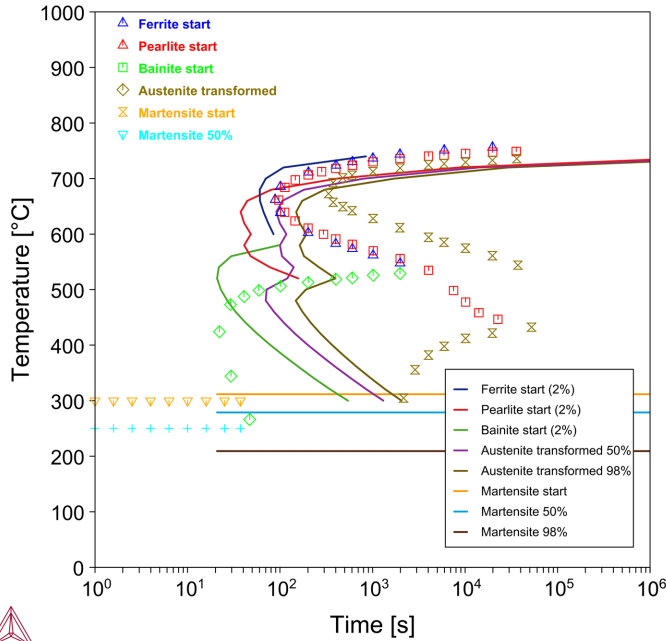

Figure 265: The TTT diagram for an Fe-C-Mn-Si-Cr-V alloy comparing the calculation with experimental data from [1958Wev].

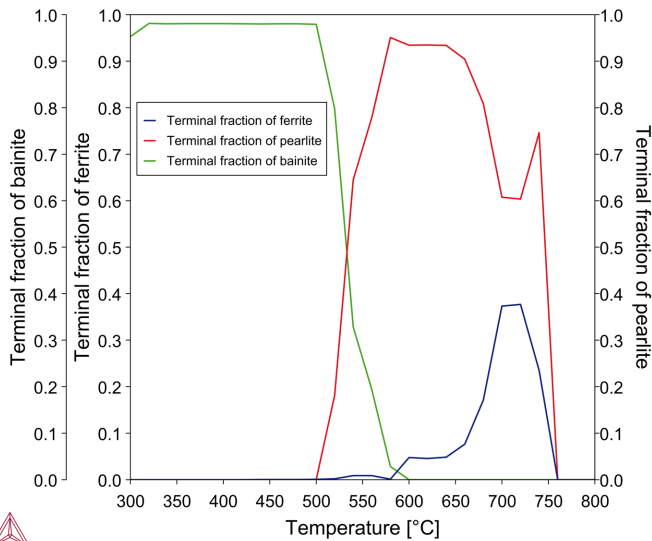

Figure 266: The terminal fractions quantities for bainite, ferrite, and pearlite are plotted against the cooling rate for the Fe-C-Mn-Si-Cr-V alloy.

Reference

[1958Wev] F. Wever, A. Rose, Atlas zur Wärmebehandlung der Stähle: 1954/56/58 (Verlag Stahleisen, Düsseldorf, 1958), p. II-112.

PM_Fe_07: Hardenability Design of Steel

This application example, which is [available on our website](#), shows how the Steel Model Library in Thermo-Calc can be used to find the optimal compositions for an Fe-Mn-C steel to achieve high hardenability for the purpose of strength.

Hardenability of steel is an important aspect of steel design because it affects the ability of the steel to develop optimum strength and toughness. Hardenability refers to the ability of steel to form martensite on quenching. It is a measure of the capacity of a steel to be hardened in depth when quenched from its austenitizing temperature, meaning that the steel forms martensite not only at the surface of the steel, but throughout the interior. This is usually a prerequisite for the subsequent tempering treatment for an optimal combination of strength and toughness. Insufficient hardenability can make the tempering treatment ineffective and lead to low uniformity of mechanical properties in a steel component. The two most important factors that influence hardenability of steel are grain size and composition, and in this example, we will investigate composition.

Project File and License Information

- Folder: **Property Models** → **Steel**
- File name: `PM_Fe_07_Hardenability_Design_of_Steel.tcu`



Although this example uses the FEDEMO and MFEDEMO databases, running the calculation requires a license for Thermo-Calc 2022b or newer and for the Steel Model Library.

Visualizations

Open the example project file to review the node setup on the **Project** window and the associated settings on the **Configuration** window for each node. For some types of projects, you can also adjust settings on the **Plot Renderer Configuration** window to preview results before performing the simulation. Click **Perform Tree** to generate plots and tables to see the results on the **Visualizations** window.



When you run (Perform) this example, it takes several hours to complete the calculations.



The resulting plots and details related to setting up this example are available to download via the [dedicated web page](#).

PM_Fe_08: CCT Diagram for Fe-C-Mn-Si-Cr-V

The example uses the **Property Model Calculator** and the **CCT Diagram** Property Model to calculate a Continuous-Cooling-Transformation (CCT) diagram for an Fe-C-Mn-Si-Cr-V alloy (Steel 42CrV6). The calculation is compared to an experimental CCT diagram for the same steel (with some other impurities) from data in [1958Wev].

A **One Axis Calculation Type** is selected on the Property Model Calculator and then the **CCT Mode** selected as the *Plot type* on the Plot Renderer in order to plot the final CCT diagram.

A second plot also shows the calculated terminal fractions of ferrite, pearlite, bainite, and martensite.

Project File and License Information

- Folder: **Property Models** → **Steel**
- File name: PM_Fe_08_Fe-C-Mn-Si-Cr-V_CCT.tcu



To run calculations with the **Steel Models** requires a valid maintenance license plus licenses for both the TCFE (version 9 and newer) and MOBFE (version 4 and newer) databases. Also see our website to learn more about the [Steel Model Library](#) and other related examples.

Visualizations



Many of our Graphical Mode examples have video tutorials, which you can access in a variety of ways. When in Thermo-Calc, from the menu select **Help** → **Video Tutorials**, or from the main My Project window, click **Video Tutorials**. Alternately, you can go to the [website](#) or our [YouTube channel](#).

Open the example project file to review the node setup on the **Project** window and the associated settings on the **Configuration** window for each node. For some types of projects, you can also adjust settings on the **Plot Renderer Configuration** window to preview results before performing the simulation. Click **Perform Tree** to generate plots and tables to see the results on the **Visualizations** window.



When you run (Perform) this example, it takes several hours to complete the calculations.

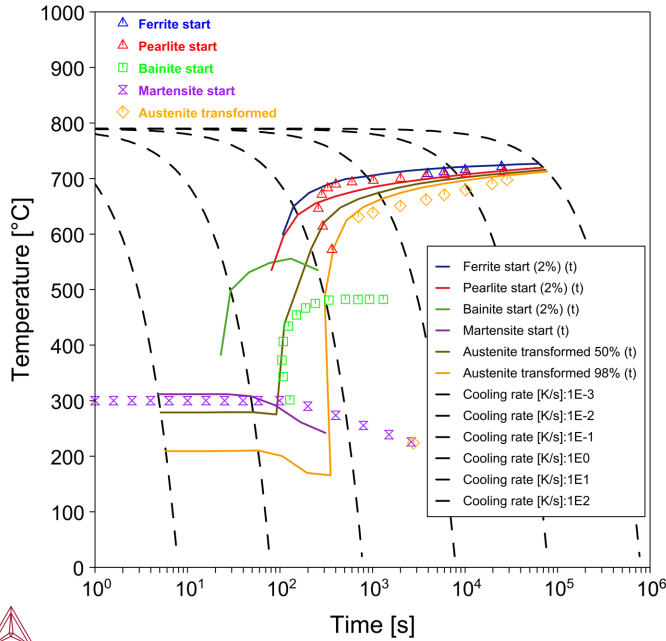

Figure 267: The CCT diagram for an Fe-C-Mn-Si-Cr-V alloy comparing the calculation with experimental data from [1958Wev].

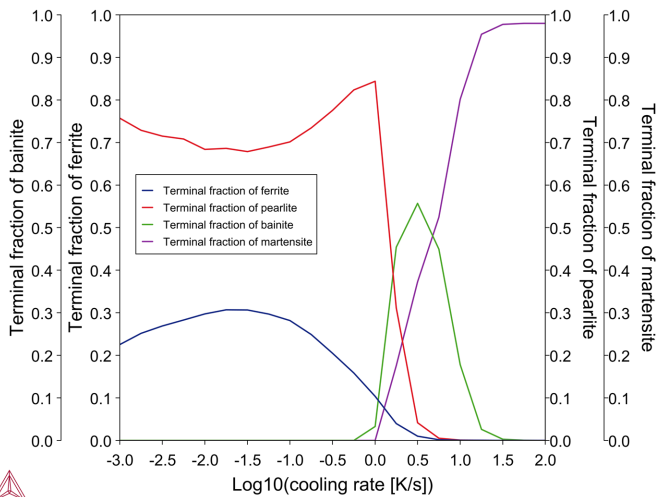

Figure 268: The terminal fractions quantities for bainite, ferrite, martensite, and pearlite are plotted against the cooling rate for the Fe-C-Mn-Si-Cr-V alloy.

Reference

[1958Wev] F. Wever, A. Rose, Atlas zur Wärmebehandlung der Stähle: 1954/56/58 (Verlag Stahleisen, Düsseldorf, 1958), p. II-112.

PM_Fe_09: Fe-C-Ni Ferrite

The example uses the **Property Model Calculator** and the **Ferrite** Property Model to calculate the ferrite fraction parabolic rate constant and ferrite start time for an Fe-0.12C-3.28Ni alloy.

Two growth modes—Orthoequilibrium (OE) and Paraequilibrium (PE)—are used with a *One Axis* calculation type to compare the ferrite molar fraction and to determine the ferrite start time for each growth mode.

The experimental data for the ferrite start is taken from [1966Aar]. For the parabolic rate constant experimental data is from [1981Bra].

Project File and License Information

- Folder: **Property Models** → **Steel**
- File name: PM_Fe_09_Fe-C-Ni_Ferrite.tcu



To run calculations with the **Steel Models** requires a valid maintenance license plus licenses for both the TCFE (version 9 and newer) and MOBFE (version 4 and newer) databases. Also see our website to learn more about the [Steel Model Library](#) and other related examples.

Visualizations



Many of our Graphical Mode examples have video tutorials, which you can access in a variety of ways. When in Thermo-Calc, from the menu select **Help** → **Video Tutorials**, or from the main My Project window, click **Video Tutorials**. Alternately, you can go to the [website](#) or our [YouTube channel](#).

Open the example project file to review the node setup on the **Project** window and the associated settings on the **Configuration** window for each node. For some types of projects, you can also adjust settings on the **Plot Renderer Configuration** window to preview results before performing the simulation. Click **Perform Tree** to generate plots and tables to see the results on the **Visualizations** window.



When you run (Perform) this example, it takes a few minutes for the calculations to complete.

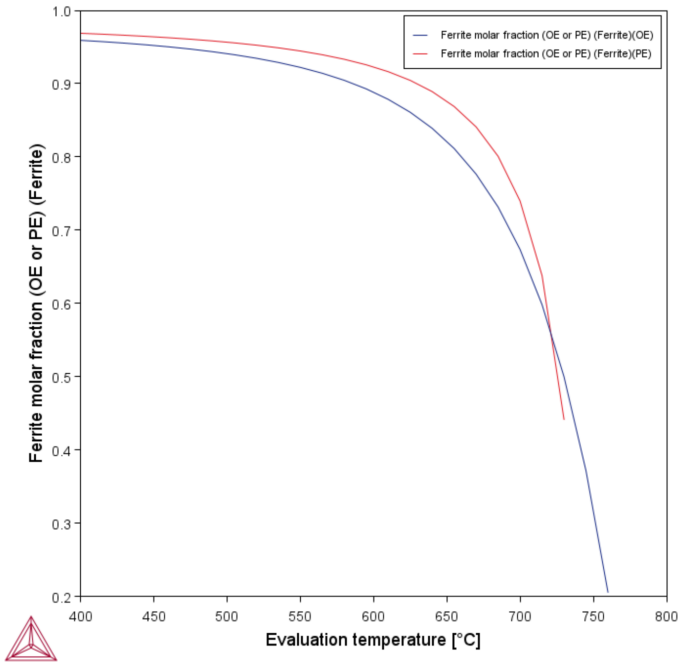

Figure 269: Ferrite fraction at the end of the transformation, under orthoequilibrium (OE) or paraequilibrium (PE).

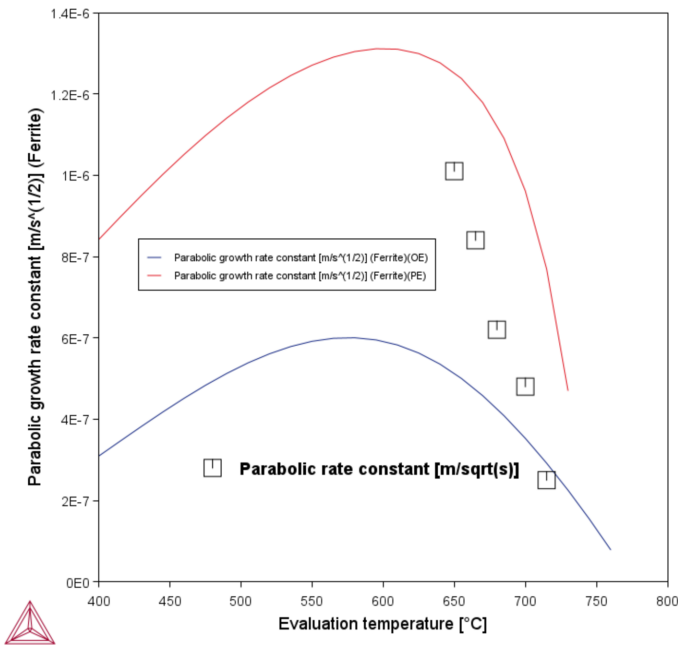

Figure 270: Parabolic rate constant. Experimental data is from [1981Bra].

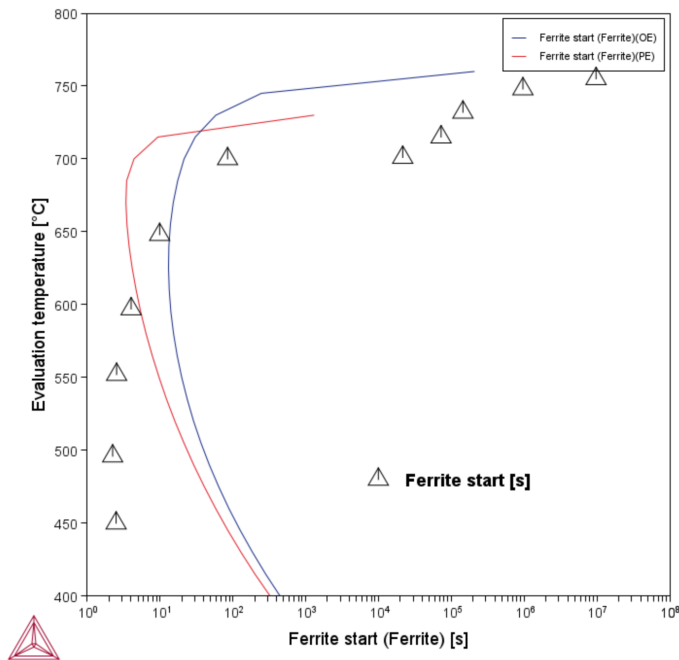

Figure 271: Ferrite start time. This plot also uses the TTT mode. Experimental data from [1966Aar].

References

- [1966Aar] H. I. Aaronson, H. A. Domian, Partition of alloying elements between austenite and proeutectoid ferrite or bainite. AIME MET SOC TRANS. 236, 781–796 (1966).
- [1981Bra] J. R. Bradley, H. I. Aaronson, Growth kinetics of grain boundary ferrite allotriomorphs in Fe-C-X alloys. Metall. Trans. A. 12, 1729–1741 (1981).

PM_Fe_10: Martensitic Steel Strength

The **Martensitic Steel Strength** Property Model, available with the Property Model Calculator and the Steel Model Library, predicts the general flow stress properties of martensitic steels, such as hardness, stress at arbitrary strain, yield strength, ultimate tensile strength, Young's modulus, etc.

The Model evaluates the following in consecutive steps:

- Martensite fraction based on composition, annealing temperature, and quench temperature
- Hardness of the as-quenched microstructure
- Effect of tempering on microstructure and hardness
- Young's modulus based on the composition of the matrix phase and contributions from precipitates
- Strain hardening response (flow stress) based on the final hardness after tempering

In this example, data for AISI4068 from [1956Gra] are compared to calculations using the **Martensitic Steel Strength** model. In the set up, one **System Definer** and two **Experimental File Reader** activities are used along with four **Property Model Calculators**. The **Martensitic Steel Strength** Property Model is used in all cases with **One Axis** calculations to produce two plots that compare the tempering temperature and time to the total hardness of tempered steels.

Project File and License Information

- Folder: **Property Models → Steel**
- File name: `PM_Fe_10_Martensitic_Steel_Strength.tcu`



To run calculations with the **Steel Models** requires a valid maintenance license plus licenses for both the TCFE (version 9 and newer) and MOBFE (version 4 and newer) databases. Also see our website to learn more about the [Steel Model Library](#) and other related examples.



This example uses TCFE13. Earlier versions of this database can be used although there may be slight differences in the results.

Visualizations



Many of our Graphical Mode examples have video tutorials, which you can access in a variety of ways. When in Thermo-Calc, from the menu select **Help** → **Video Tutorials**, or from the main My Project window, click **Video Tutorials**. Alternately, you can go to the [website](#) or our [YouTube channel](#).

Open the example project file to review the node setup on the **Project** window and the associated settings on the **Configuration** window for each node. For some types of projects, you can also adjust settings on the **Plot Renderer Configuration** window to preview results before performing the simulation. Click **Perform Tree** to generate plots and tables to see the results on the **Visualizations** window.



For some Windows-based systems, performing the full calculation from the top **My Project** node can result in out of memory issues due to the number of calculators. If this happens, perform individual calculations for each Property Model Calculator (e.g. right-click the node and select **Perform Now**). This produces the full plots that are output to the Visualizations window.



When you run (Perform) this example, it takes a few minutes for the calculations to complete.

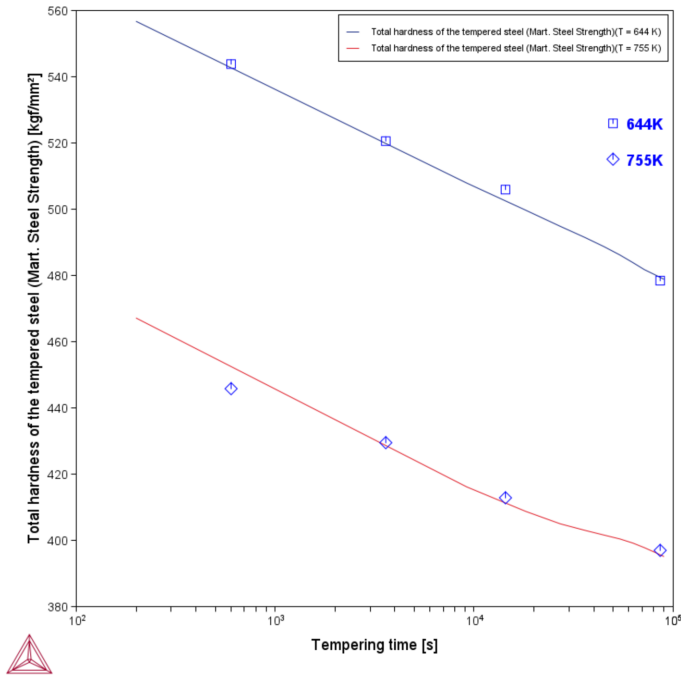

Figure 272: Total hardness of the tempered steel versus tempering time, for two tempering temperatures, compared to data from [1956Gra].

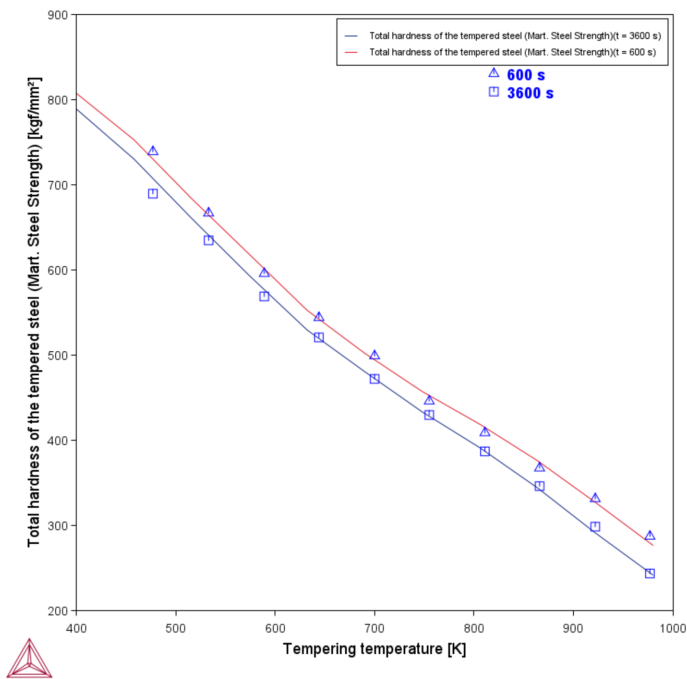

Figure 273: Total hardness of the tempered steel versus tempering temperature, for two tempering times, compared to handbook data from [1956Gra].

Reference

[1956Gra] R.A. Grange and R.W. Baughman. Hardness of tempered martensite in carbon and low alloy steels, Transactions of American Society for Metals, Vol. XLVIII, 165–197 (1956).

PM_Fe_11: Steel Design Using the Parallel Coordinates Plot

The example uses the **Property Model Calculator** and three Property Models to plot a property diagram and a **Parallel coordinates** plot for chemistries centered around an Fe_{1.5}Cr_{2.0}Ni_{0.31}C_{1.0}Mn alloy. The Ni, Cr, and C chemistries are varied to understand their influence on some key properties. This can be used to optimize a material chemistry to meet specific design criteria.

A **One Axis** calculation using the **Equilibrium Calculator** produces a property diagram to show the equilibrium fractions of the alloy.

A second calculation uses a **Grid** calculation with the Property Model Calculator and the **Driving Force, Martensite Temperatures, and Martensitic Steel Strength** models to demonstrate the use of the **Parallel coordinates** plot type. The driving force model in this example calculates the driving force for Cementite to form at 500 °C (tempering temperature). The driving force gives a good idea of how fine a dispersion of carbides could form. Higher driving force means a finer distribution.

When using a parallel coordinates plot type, you can interpret multidimensional data to compare how different parameters affect each other. In this example this includes the *composition of Ni, Cr, and C* (each in mass percent), the *Driving force per mole*, the *Total hardness of the tempered steel*, and the *Ms temperature*.

Project File and License Information

- Folder: **Property Models → Steels**
- File name: `PM_Fe_11_Steel_Design_Using_Parallel_Plot.tcu`



To run calculations with the **Steel Models** requires a valid maintenance license plus licenses for both the TCFE (version 9 and newer) and MOBFE (version 4 and newer) databases. Also see our website to learn more about the [Steel Model Library](#) and other related examples.



This example uses TCFE13. Earlier versions of this database can be used although there may be slight differences in the results.

Visualizations



Many of our Graphical Mode examples have video tutorials, which you can access in a variety of ways. When in Thermo-Calc, from the menu select **Help** → **Video Tutorials**, or from the main My Project window, click **Video Tutorials**. Alternately, you can go to the [website](#) or our [YouTube channel](#).

Open the example project file to review the node setup on the **Project** window and the associated settings on the **Configuration** window for each node. For some types of projects, you can also adjust settings on the **Plot Renderer Configuration** window to preview results before performing the simulation. Click **Perform Tree** to generate plots and tables to see the results on the **Visualizations** window.



When you run (Perform) this example, it takes a few minutes for the calculations to complete.

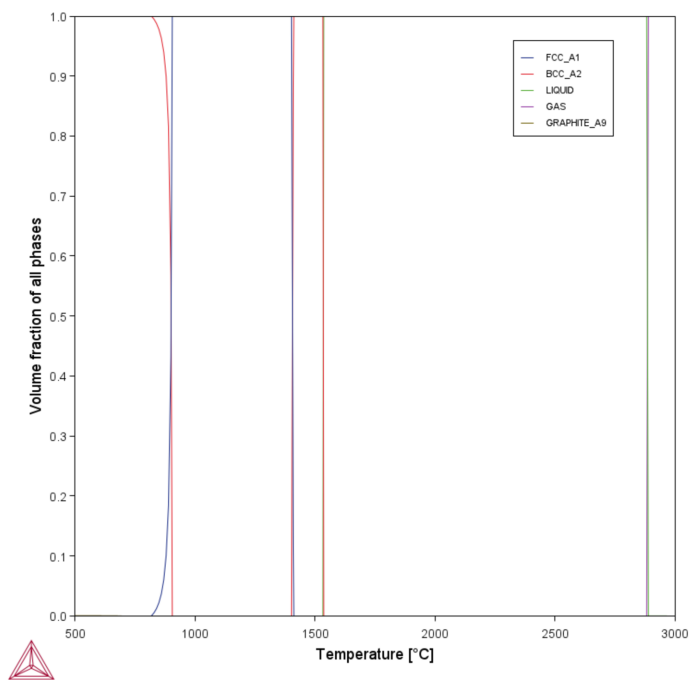

Figure 274: A Property Diagram to observe the change in volume fraction of all phases as the temperature increases.

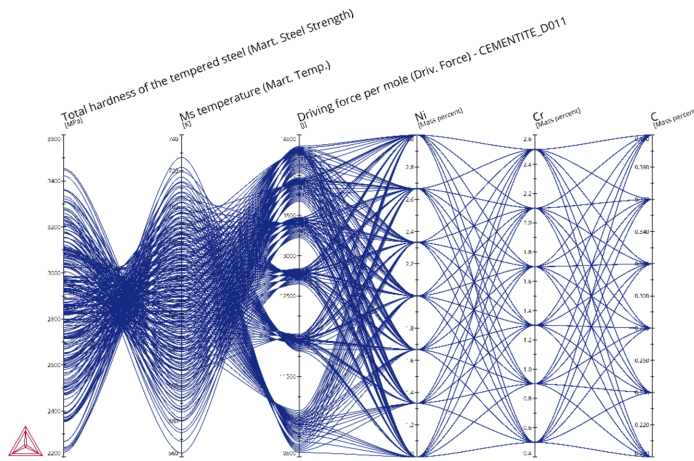

Figure 275: A parallel coordinates plot with multidimensional data comparing the Ni, Cr, and C compositions, the Driving force per mole, the Total hardness of the tempered steel, and the Ms temperature.

Tips to Interpret the Plot Data

- When most lines between two parallel axes are somewhat parallel to each other, there is a positive relationship between these two dimensions.
- When lines cross in a kind of superposition of X-shapes, that is a negative relationship.
- When lines cross randomly it means that there is no particular relationship.

PM_Fe_12: Flow Stress 15-5PH Steel

The example uses the **Property Model Calculator** and the **Martensitic Steel Strength** model to calculate the flow stress curves for a 15-5PH steel alloy, with samples tempered for 2, 5, and 50 hours. The example shows the use of flow stress with this Property Model.

An **Experimental File Reader** is used with data from Croné et al. [2022Cro]. Three Property Model Calculators are used with a **Flow stress mode** of σ vs ϵ and a **One Axis** calculation is used.

The **Tempering time** is set for each Property Model Calculator to 2 h, 5 h, and 50 h (the settings themselves are entered in seconds).

Project File and License Information

- Folder: **Property Models** → **Steels**
- File name: `PM_Fe_12_Flow_Stress_15-5PH_Steel.tcu`



To run calculations with the **Steel Models** requires a valid maintenance license plus licenses for both the TCFE (version 9 and newer) and MOBFE (version 4 and newer) databases. Also see our website to learn more about the [Steel Model Library](#) and other related examples.



This example uses TCFE14. Earlier versions of this database can be used although there may be slight differences in the results.

Visualizations



Many of our Graphical Mode examples have video tutorials, which you can access in a variety of ways. When in Thermo-Calc, from the menu select **Help** → **Video Tutorials**, or from the main My Project window, click **Video Tutorials**. Alternately, you can go to the [website](#) or our [YouTube channel](#).

Open the example project file to review the node setup on the **Project** window and the associated settings on the **Configuration** window for each node. For some types of projects, you can also adjust settings on the **Plot Renderer Configuration** window to preview results before performing the simulation. Click **Perform Tree** to generate plots and tables to see the results on the **Visualizations** window.

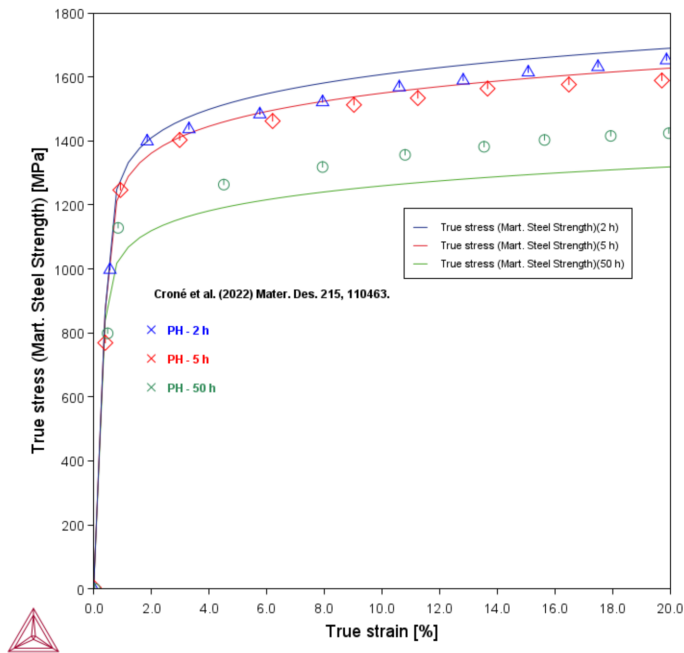

Figure 276: The calculation plots the True strain [%] to the True stress [MPa] as flow stress curves and compares it to experimental data taken from [2022Cro].

Reference

[2022Cro] P. Croné, T. Zhou, P. Hedström, J. Odqvist, P. Gudmundson, J. Faleskog, Continuum plasticity modelling of work hardening for precipitation-hardened martensitic steel guided by atom probe tomography. Mater. Des. 215, 110463 (2022).

Titanium Model Library Examples Collection



The **General Models** are available to all users. To run calculations with the **Titanium Models** (as part of the Titanium Model Library) requires a valid maintenance license plus a license for the TCTI (version 6 and newer) database.

These examples use the **Property Model Calculator**, an activity available with Thermo-Calc plus the available Property Models in the Titanium Model Library.

In this section:

PM_Ti_01: Martensite Temperatures for Ti-Zr	426
PM_Ti_02: Alloy Strength for Ti-O	429

PM_Ti_01: Martensite Temperatures for Ti-Zr

The **Martensite Temperatures - Ti** Property Model, available with the Property Model Calculator and the Titanium Model Library, calculates the martensite start temperature (Ms) and T-Zero temperatures for Ti-base alloys.

Choose between **HCP** (α , α' , or α'') and **B19_PRIME** or **B19_ORTHO** as the **Martensite phase**:

- The HCP phase is the common choice for alloys such as Ti-6Al-4V and other structural alloys.



The various forms of alpha martensite (α , α' , or α'') are not explicitly distinguished and are therefore collectively described by HCP_A3 in terms of thermodynamic properties.

- The B19_PRIME and B19_ORTHO options are intended for TiNi-based shape-memory alloys.
- The B19_ORTHO is useful for TiNiCu-based shape-memory alloys.

This example uses the **Martensite Temperatures - Ti** Property Model with a simple Ti-Zr system to show the use of this model. A **One Axis** calculation is used to plot the Ms and T-Zero temperatures as a function of mole fraction of Zr with experimental data from [1952Du, 1965McM, and 1970Hua].

Project File and License Information

- Folder: **Property Models** → **Titanium**
- File name: PM_Ti_01_Martensite_Temperatures_Ti-Zr.tcu



To run calculations with the **Titanium Models** requires a valid maintenance license plus a license for the TCTI (version 6 and newer) database. For some Property Models, additional recommendations for the database version to use is indicated in its description. Also see our [website](#) to learn more about the Titanium Model Library.

Visualizations



Many of our Graphical Mode examples have video tutorials, which you can access in a variety of ways. When in Thermo-Calc, from the menu select **Help** → **Video Tutorials**, or from the main My Project window, click **Video Tutorials**. Alternately, you can go to the [website](#) or our [YouTube channel](#).

Open the example project file to review the node setup on the **Project** window and the associated settings on the **Configuration** window for each node. For some types of projects, you can also adjust settings on the **Plot Renderer Configuration** window to preview results before performing the simulation. Click **Perform Tree** to generate plots and tables to see the results on the **Visualizations** window.



When you run (Perform) this example, it takes a few minutes for the calculations to complete.

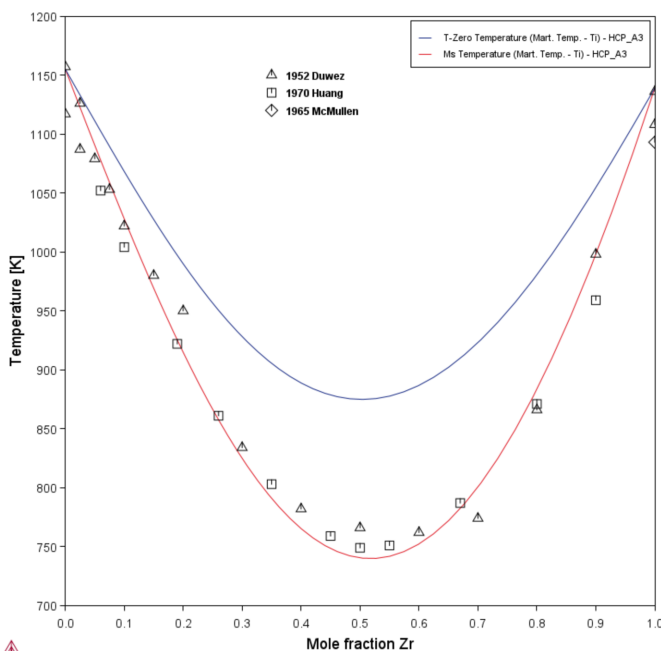

Figure 277: Ms and T-Zero temperatures as a function of mole fraction of Zr with experimental data from [1952Du, 1965McM, and 1970Hua].

References

[1952Du] P. Duwez, Allotropic transformation in titanium-zirconium alloys. J. Inst. Met. 80, 525–527 (1952).

[1965McM] A. G. McMullen, J. Gordon Parr, The Transformation in Zirconium-Niobium Alloys with an Appendix on Thermocouple Alloying with Zirconium. *Can. Metall. Q.* 4, 117–128 (1965).

[1970Hua] Y.C. Huang, S. Suzuki, H. Kaneko, T. Sato, Thermodynamics of the Ms points in titanium alloys, in: R.I. Jaffee, N.E. Promisel (Eds.) *The Science, Technology and Application of Titanium*, Pergamon Press, 1970, pp. 691-693.

PM_Ti_02: Alloy Strength for Ti-O

The **Alloy Strength - Ti** Property Model, available with the Property Model Calculator and the Titanium Model Library, calculates the strength and hardness for Ti-base alloys.



The various forms of alpha martensite (α , α' , or α'') are not explicitly distinguished and are therefore collectively described by HCP_A3 in terms of thermodynamic properties.

This example uses the **Alloy Strength - Ti** Property Model to determine the total hardness of a Ti-0.04Fe-0.03C-0.005N-0.01O alloy.

A **One Axis** calculation is done using the latest version of the TCTI database to compare the total hardness vs oxygen content (in mole %). Two **Experimental File Readers** provide the data from [1950Fin] and [1973Oka] for comparison with the calculated values.

As is clearly illustrated in this example, the effect of typical impurity elements on the strength and hardness of Ti is very large. It is therefore important to keep in mind that the impurity elements and their respective contents should be included in the calculation, either explicitly, as is done in this example, or by selecting an appropriate base grade with a pre-defined impurity content for the calculation.

Project File and License Information

- Folder: **Property Models** → **Titanium**
- File name: `PM_Ti_02_Alloy_Strength_Ti-O.tcu`



To run calculations with the **Titanium Models** requires a valid maintenance license plus a license for the TCTI (version 6 and newer) database. For some Property Models, additional recommendations for the database version to use is indicated in its description. Also see our [website](#) to learn more about the Titanium Model Library.

Visualizations



Many of our Graphical Mode examples have video tutorials, which you can access in a variety of ways. When in Thermo-Calc, from the menu select **Help** → **Video Tutorials**, or from the main My Project window, click **Video Tutorials**. Alternately, you can go to the [website](#) or our [YouTube channel](#).

Open the example project file to review the node setup on the **Project** window and the associated settings on the **Configuration** window for each node. For some types of projects, you can also adjust settings on the **Plot Renderer Configuration** window to preview results before performing the simulation. Click **Perform Tree** to generate plots and tables to see the results on the **Visualizations** window.



When you run (Perform) this example, it takes a few minutes for the calculations to complete.

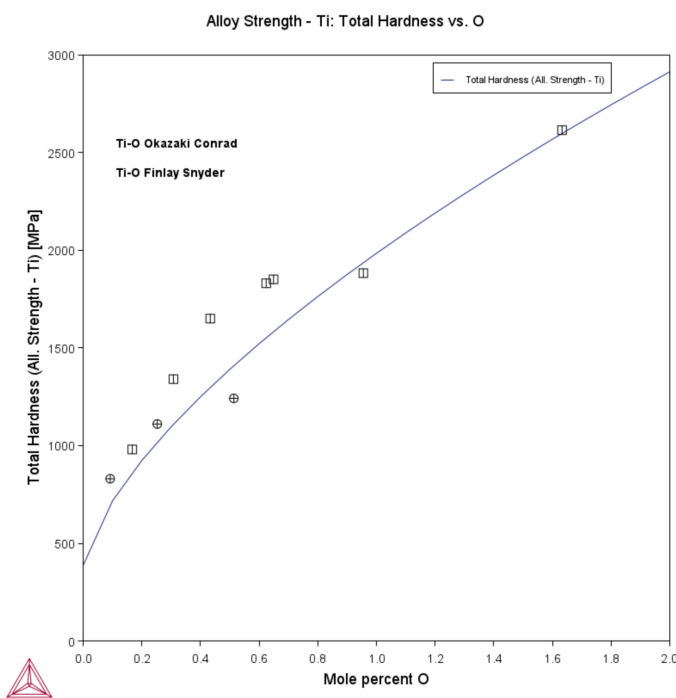

Figure 278: The total hardness vs O (in mole %) is shown with data from [1950Fin] and [1973Oka].

References

[1950Fin] W. L. Finlay, J. A. Snyder, Effects of three interstitial solutes (nitrogen, oxygen, and carbon) on the mechanical properties of high-purity, alpha titanium. JOM. 2, 277–286 (1950).

[1973Oka] K. Okazaki, H. Conrad, Effects of interstitial content and grain size on the strength of titanium at low temperatures. *Acta Metall.* 21, 1117–1129 (1973).
